

AC-PRO-MP® & AC-PRO-MP-II®

I-AC-PRO-MP

MASTERPACT MP DIRECT
REPLACEMENT TRIP UNIT

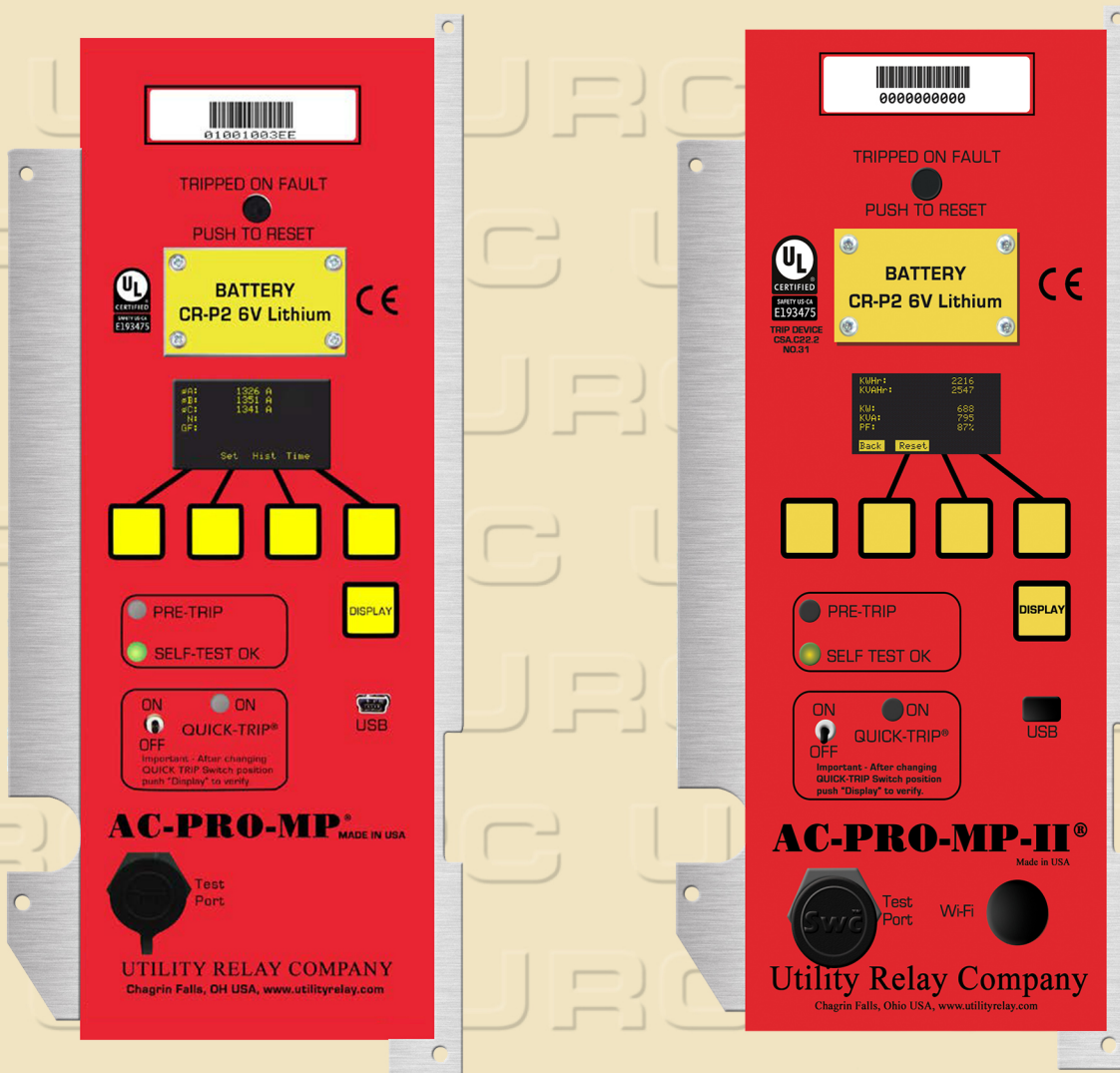

INSTRUCTION MANUAL

*Plug-in Replacement Trip Unit for Masterpact MP
Type STR-18M, 28D, 38S, or 58U*

URC Utility Relay Company

Chagrin Falls, OH 44023
Phone: 888.289.2864
www.utilityrelay.com



WARNING: Low voltage power circuit breakers contain stored energy spring operating mechanisms. For maximum personnel protection when installing and testing this retrofit kit, the following procedures must be followed. Failure to follow these procedures could result in property damage, personal injury, or death.

NO work shall be performed on an energized breaker.

Only qualified persons, as defined by the National Electric Code, and preferably NETA Certified or Pearl Certified Technicians, who are familiar with the operation and maintenance of low voltage power circuit breakers and their associated switchgear assemblies should perform the installation of this retrofit kit.

Completely read and understand all instructions before attempting the installation and testing of this retrofit kit. Personnel are available at Utility Relay Company during normal working hours (Eastern Standard Time) to answer any questions.

Turn off and lockout the power source(s) supplying the breaker prior to removing the breaker and attempting any work on the breaker. Follow all lockout and tagging rules of the National Electric Code and all other applicable codes, regulations and work rules.

Do not perform any work including charging, closing or tripping or any other function that could cause significant movement of a draw out breaker while it is on the extension rails.

For both draw out and bolt-in breakers, trip open and then move the breaker to a well-lighted work area with a sturdy workbench before starting the retrofit.

Do not work on a closed breaker or a breaker with the closing springs charged. Trip open the breaker and make sure any stored energy springs are discharged before performing any work. If this is disregarded, the breaker may unexpectedly trip open or the charging springs may discharge, causing severe injuries.

Under some circumstances it may be necessary to charge the springs and close the breaker to make/verify certain retrofit adjustments. In those instances, use extreme caution to stay clear of any moving components in case the breaker either purposely or unexpectedly trips open or the charging springs discharge.

Refer to the latest edition of the ANSI/NETA Standard for Maintenance Testing Specifications for bolt tightening torque specifications.

01/01/15

LIMITED WARRANTY

Utility Relay Company warrants that every AC-PRO, ZERO-Hertz, AC-PRO-MP, AC-PRO-MP-II, and AC-PRO-II trip unit and related retrofit kit components (herein collectively referred to as "product") shall be free from defects in material and workmanship, and will perform as described in Utility Relay Company's sales literature and Instruction Manuals, under normal use and service for a period of (2) two years from date of invoice. EXCEPT AS SET FORTH HEREIN, IT IS EXPRESSLY AGREED THAT THERE IS NO WARRANTY OF MERCHANTABILITY OR FITNESS FOR A PARTICULAR PURPOSE, AND THERE IS NO OTHER WARRANTY, EXPRESS, IMPLIED OR STATUTORY, BY UTILITY RELAY COMPANY WITH REFERENCE TO THE PRODUCT.

Should any warranty claim arise within the warranty period, contact Utility Relay Company at 888-289-2864 and do the following:

- 1.) Provide a complete description of the problem with the trip unit or retrofit kit component.
- 2.) Provide the Serial Number located on the trip unit from the warranted retrofit kit.
- 3.) Obtain a Returned Materials Authorization number (RMA) and return shipping instructions.
- 4.) Promptly return the defective material to Utility Relay Company.

Warranty Disclaimer and Liability Limitation

As the sole and exclusive remedy, Utility Relay Company will repair or replace the trip unit and/or retrofit component(s) at no cost to the customer during the warranty period. Removal or reinstallation of a warranted trip unit and/or retrofit component(s) are the responsibility of the customer. The customer is liable and shall pay for shipment of defective products back to Utility Relay Company. In no event shall Utility Relay Company be liable for any special, incidental or consequential damages.

Excluded from this warranty and not warranted by Utility Relay Company in any fashion, either expressed or implied are:

- 1.) Any product which has been disassembled (except to replace batteries), repaired, tampered with, altered, changed, or modified by persons other than Utility Relay Company's own authorized service personnel unless repair by others is made with the written consent of Utility Relay Company.
- 2.) Defects or damage to the Product resulting from wear, tear, misuse, negligence, improper storage, improper testing, impacts, or use with non-approved accessories.
- 3.) Products used for any other purpose other than originally intended by Utility Relay Company.

Visit www.utilityrelay.com or call 888-289-2864 for latest warranty information.

10/13/15

Table of Contents

Manual Rev 6.0

Section:	Page	Section:	Page
1.0 Introduction	1	21.0 Time Current Curves.....	27
2.0 General	2	21.1 AC-PRO-MP & MP-II STR-18M TCC.....	28
2.1 Front View.....	2	21.2 AC-PRO-MP & MP-II STR-28D TCC	29
2.2 Rear View	3	21.3 AC-PRO-MP & MP-II STR-38S TCC	30
2.3 Top View.....	3	21.4 AC-PRO-MP & MP-II STR-58U TCC	31
3.0 Installation.....	4	21.5 AC-PRO-MP & MP-II	
3.1 Remove Front Cover.....	4	STR-38S & 58U GF TCC.....	32
3.2 Disconnect STR Wiring.....	4	21.6 AC-PRO-MP & MP-II	
3.3 Remove STR Trip Unit.....	5	STR-58U Load Monitoring TCC.....	33
3.4 Installing Voltage Connections (MP-II).....	5	21.7 AC-PRO-MP & MP-II	
3.5 Connect CT Connectors	6	QUICK-TRIP® Instantaneous TCC.....	34
3.6 Attach AC-PRO-MP or MP-II		21.8 AC-PRO-MP & MP-II	
to Breaker	7	QUICK-TRIP® GF TCC	35
3.7 Check Alignment of		21.9 AC-PRO-MP or MP-II	
“Push-to-Reset” Rod	7	Neutral Overload TCC	36
3.8 Auxiliary Wiring Connections	7		
3.9 Insert the Auxiliary Terminal Blocks into			
the Lower Control Unit	8		
3.10 Modify & Install Terminal Block Cover	8		
3.11 Installing the Breaker Position			
Limit Switch.....	9		
3.12 Communications connections (MP-II)	11		
3.13 Replace Breaker Front Cover	11		
4.0 Settings	12		
4.1 Change Settings Using the Front Panel...	12		
4.2 Reviewing Settings	16		
4.3 Setting the Time & Date	16		
4.4 USB Interface and InfoPro-MP-II	16		
5.0 Normal Operations & Readings	17		
5.1 Current & Voltage Readings	17		
5.2 Power & Energy Readings.....	17		
6.0 QUICK-TRIP® Arc Flash Reduction	18		
6.1 Local QUICK-TRIP® Switch	18		
6.2 Remote QUICK-TRIP®			
(via Communications)	19		
7.0 SAFE-T-TRIP®	20		
8.0 SLUGGISH BREAKER® Detection	20		
9.0 Last Trip Data	21		
10.0 Replacing the Battery.....	21		
11.0 Self-Test Feature	22		
12.0 Primary & Secondary Injection Testing	22		
12.1 Primary Injection Testing.....	22		
12.2 Secondary Injection Testing.....	22		
13.0 DINF Instantaneous Trip.....	23		
14.0 FV Segregated Trip Relay.....	24		
15.0 ALR Pre-Trip Alarm Relay.....	24		
16.0 Ic1 & Ic2 Load Monitoring Relays	24		
17.0 Communications (MP-II)	25		
17.1 Communications Components.....	25		
17.2 Communications Wiring	25		
17.3 System Components			
& Computer Hardware	25		
17.4 Ethernet	25		
17.5 Modbus Communications Register Map ..	25		
17.6 Communications Settings	25		
18.0 InfoPro-MP or MP-II Software	26		
18.1 Firmware Versions & Updates	26		
19.0 Warranty	27		
20.0 Environmental Ratings.....	27		

For latest version, visit:

http://www.utilityrelay.com/Side_Bar/Instruction_Manuals.html

1.0 Introduction

The AC-PRO-MP & AC-PRO-MP-II are plug-in, direct replacement trip units for the STR trip units on the Merlin Gerin & Square D Masterpact MP breakers.

The AC-PRO-MP & MP-II offer the following features:

- User programmed to replace any of the versions of STR-18M, 28D, 38S or 58U trip units on IEC or UL rated Masterpact MP breakers.
- A security code system protects against unauthorized changes to the settings.
- Includes the exact trip unit functions, settings and time-current-curves as the original STR trip unit.
- Includes the same information and alarm features as the original STR trip unit.
- Includes additional self-test features.
- No physical rating plug is required. The required rating plug value is a programmed setting.
- Includes the QUICK-TRIP® arc flash reduction settings with an On/Off switch and LED on the front of the trip unit as a standard feature.
- Remote QUICK-TRIP control and indication capabilities.
- Easy access to the settings and last trip data is provided with an OLED display and “smart” push buttons.
- A USB port on the front of the trip unit provides for connection to a laptop computer for easy access to the settings and last trip data using InfoPro-MP or MP-II software.
- The USB port also supports the SAFE-T-TRIP® remote hand-held trip device.
- A test port for connection to a secondary injection test set that performs actual Phase and Ground Fault tests, not simulated tests.
- Patented SLUGGISH BREAKER® detection captures mechanism time. It provides a warning if the time is over 33 milli-seconds. The alarm relay can also be set to operate for this condition.
- Detailed Trip data for the last 8 trips, including timestamps.

AC-PRO-MP & AC-Pro-MP-II trip units shipped December 2016 & later include the following additional features/updates:

- Secondary Injection Test port is located on front of unit.
- Waveform capture (on-demand and for the last 8 trips)
- A breaker limit switch is used for SLUGGISH BREAKER detection.
- Neutral Overload protection can be turned on to protect the neutral conductor using the Long Time settings.
- Remote QUICK-TRIP control and indication capabilities is available over Modbus RTU communications instead of hardwired connections.
- InfoPro-MP-II software is used.
- The firmware in these units is different than the firmware in units shipped before December 2016 (units shipped before December 2016 have a side secondary injection test port).

The AC-PRO-MP-II includes the following additional features (24VDC control power required):

- Voltage metering (line-to-line) (rated for up to 600V three-phase systems)
- Power and energy metering (KW, KVA, KWhrs, KVAHrs, Power Factor)
- Modbus RTU communications via RS-485 network

Zone Select Interlocking (ZSI) is not currently available.
Wi-Fi Communications is not currently available.

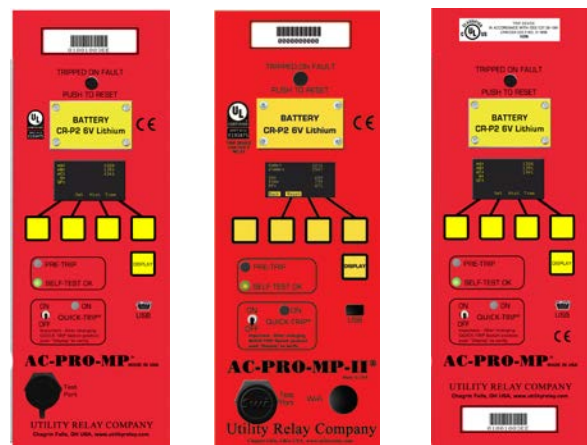

AC-PRO-MP with front test port (shipped December 2016 or later)

AC-PRO-MP-II with front test port (released December 2016)

AC-PRO-MP (shipped prior to December 2016)

2.0 General

2.1 Front View

A. Pop-out tripped indicator

This indicator is mechanically interlocked to the breaker mechanism and pops out when the breaker is tripped by the trip unit.

After a trip, the pop-out indicator must be pushed to the flush position before the breaker can be closed.

B. Battery Cover

To replace the battery, remove the four (4) 2-56 screws and battery cover, remove the old battery and insert a new CR-P2, 6 Volt Lithium battery. Replace the battery cover and screws. See Section 10.0.

C. OLED Display

The display is normally off. Pushing the DISPLAY button (E) turns on the display.

D. "Smart" Push Buttons

These push buttons perform the functions indicated on the bottom of the OLED display.

E. DISPLAY Push Button

Pushing the DISPLAY button will turn on the display. If no buttons are pushed for 30 seconds, the display will turn off.

F. Red Pre-Trip LED

Depending on the magnitude of the largest Phase current, this LED will be:

- Off if less than 90% of LT Pick-Up
- Solidly on if greater than 90% but less than 105% of LT Pick-Up
- Flashing if greater than 105% of LT Pick-Up

G. Green Self Test OK LED

When the trip unit is powered up, this LED is on unless a problem is detected.

H. USB Connector

USB 2.0 Mini-B connector for use with InfoPro-MP or InfoPro-MP-II software and SAFE-T-TRIP® device.

I. QUICK-TRIP® on/off Switch

When this switch is in the on position, the QT-I and QT-GF functions are active for reduction of arc flash hazard.

J. Secondary Injection Test Port

Removing the test port cover on the front of the trip unit allows connection of the secondary injection test set

K. Red QUICK-TRIP® on LED

When this LED is on, the QT-I and QT-GF functions are active because either the local (J) or remote QUICK-TRIP function is on.

L. Serial Number

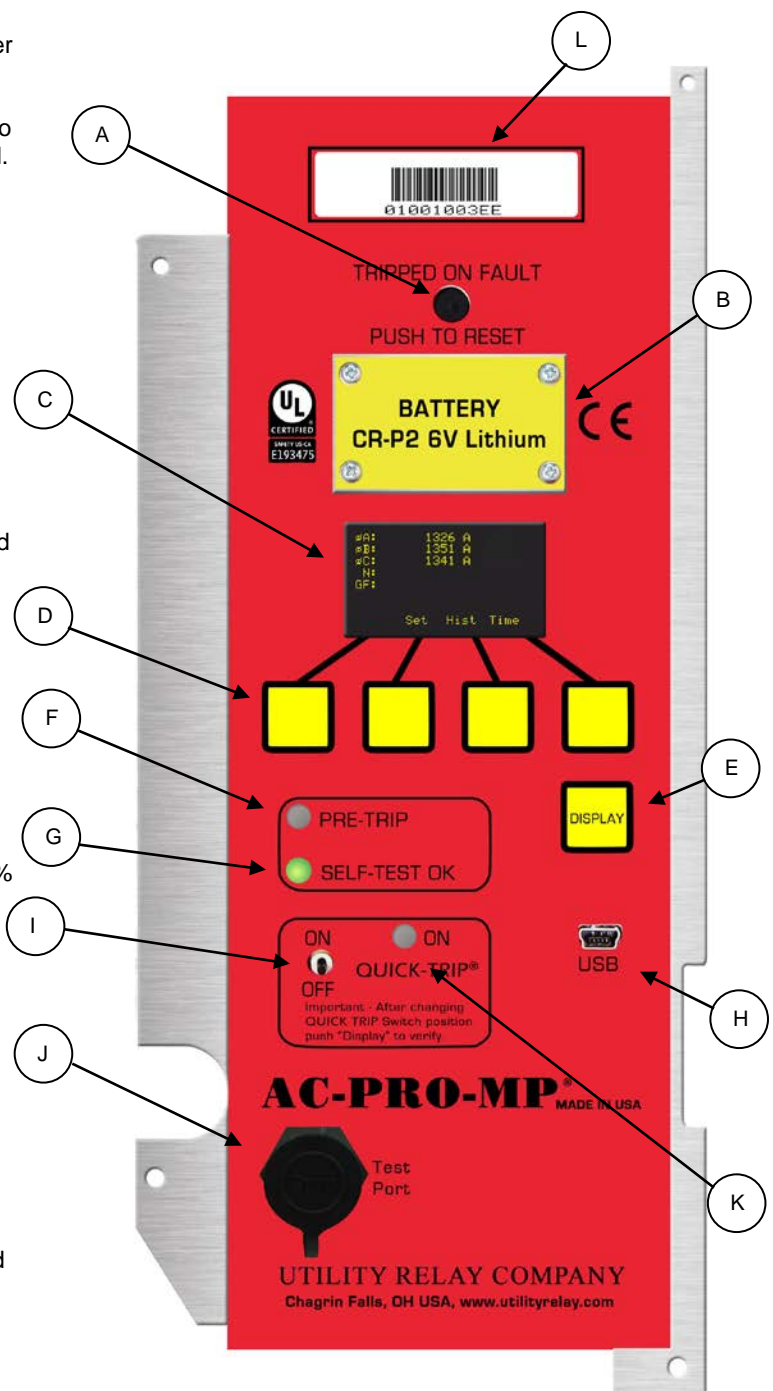

2.2 Rear View

- A. DINF Instantaneous Connector
 Not on all breakers.
 The DINF Instantaneous trip function is lower than the standard Instantaneous settings allowed for a particular CT rating. The DINF Instantaneous trip function is only enabled for a short time while the breaker is closing. After the breaker is fully closed and latched, the DINF micro-switch defeats the DINF Instantaneous function.
 Remove and discard the jumper when connecting the DINF cable.

Important:

If the breaker does not have a DINF cable, leave the jumper in place or DINF Instantaneous will always be on.

- B. 24 Vdc ALIM EX Connector
 Not on all breakers.
 This connector brings the auxiliary 24 Vdc control power to the trip unit.
- C. MITOP Connector
 This is the actuator connector. If required, use the extension cable (item I) to connect to the breaker cable.
- D. TH Connector
 Not on all breakers.
 This is the thermistor connector. If the breaker temperature as measured by the thermistor exceeds 105°C, an over temperature trip is initiated by the trip unit. Use the extension cable (Item I) to connect to the breaker cable.

- E. N Connector - Neutral CT connector
- F. PH1 Connector
 Phase "A" CT connector.
- G. PH2 Connector
 Phase "B" CT connector.
- H. PH3 Connector.
 Phase "C" CT connector.

- I. Extension cable for TH and MITOP connection.
- J. Voltage wire leads (AC-PRO-MP-II only)
 Phase C, B, A (rear view, left to right)
 (See Section 3.4)

2.3 Top View

- K. RS-485 connector (AC-PRO-MP-II only).
 See Section 3.12.
 (For units shipped before December 2016, this connector is used for Remote QUICK-TRIP. See Section 6.2)
- L. Auxiliary Wiring Connector.
 See Section 3.8.

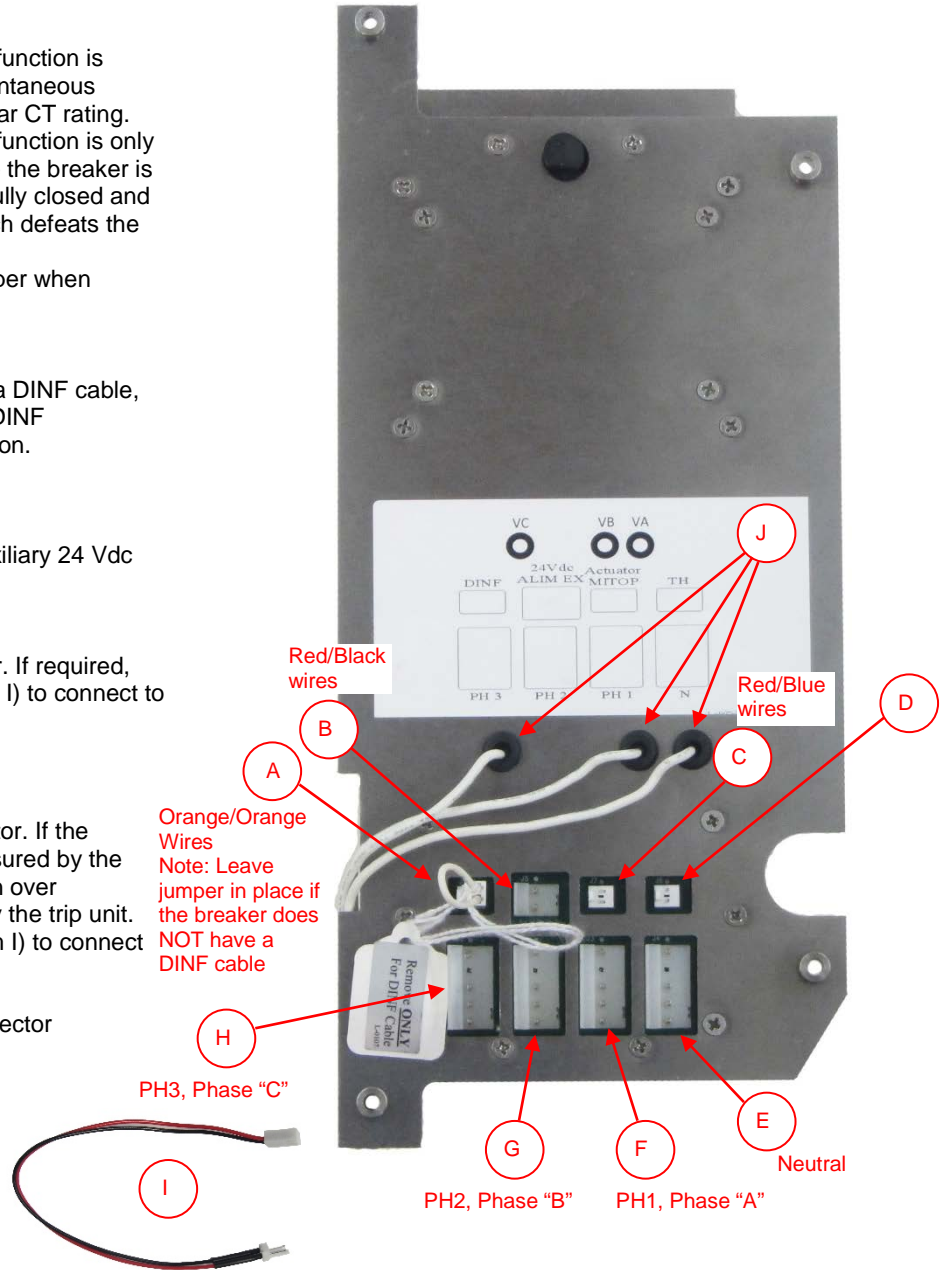

Rear View

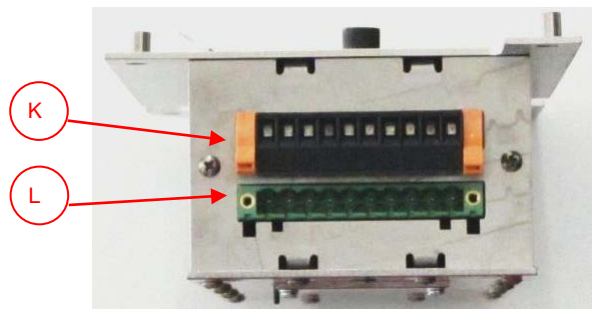

Top View

3.0 Installation

3.1 Remove Front Cover



Remove the five cover screws and remove the front cover.

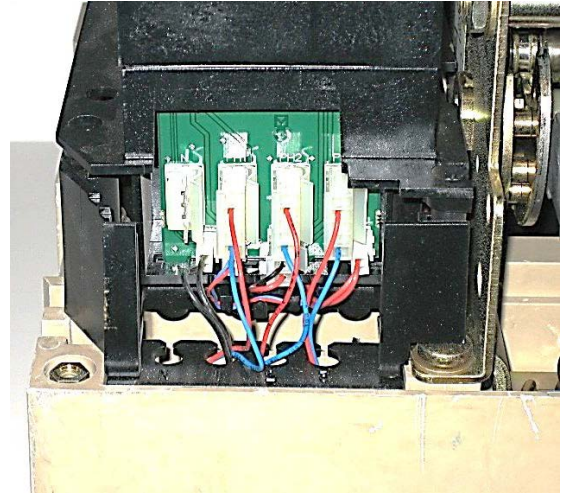

Remove the bottom wire cover.

3.2 Disconnect STR Wiring



Lay breaker down onto the rear stabs.

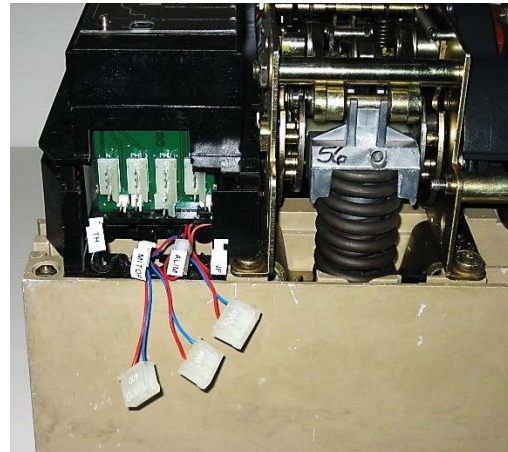

Unplug the three (3) Phase CT connectors. Unplug the Neutral CT connector if applicable. Unplug the other connectors. Label all connectors to avoid confusion.

3.3 Remove the STR Trip Unit

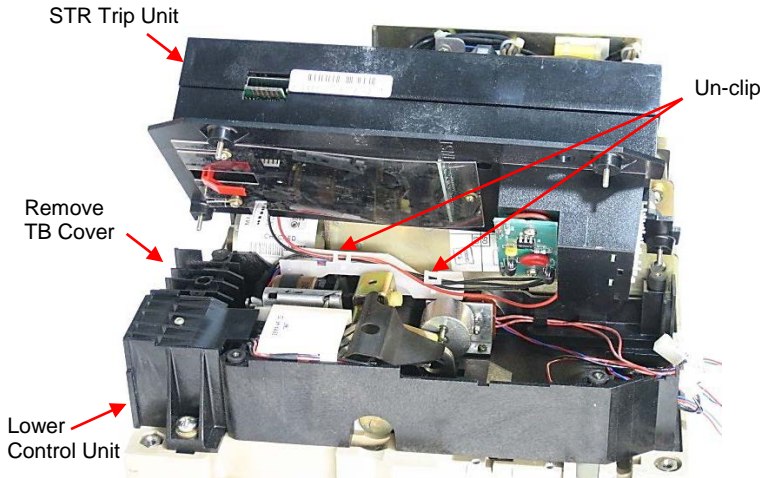

Remove the four (4) screws attaching the STR trip unit to the lower control unit.

Un-clip the two (2) wire-way latches and pull out the wires.

Remove the right terminal block cover.

3.4 Installing the Voltage Connections (AC-PRO-MP-II)

Locate the 3-pole fuse block on the existing trip unit mounting carriage as shown. Using the two (2) round holes in the fuse block as a guide, mark the location of the two (2) round holes on the trip unit carriage.

Drill and tap two (2) 8-32 holes in the trip unit carriage where marked.

Mount the 3-pole fuse block to the trip unit carriage using two (2) 8-32 x 1-1/8 Male/Female standoffs and lock washers as shown.

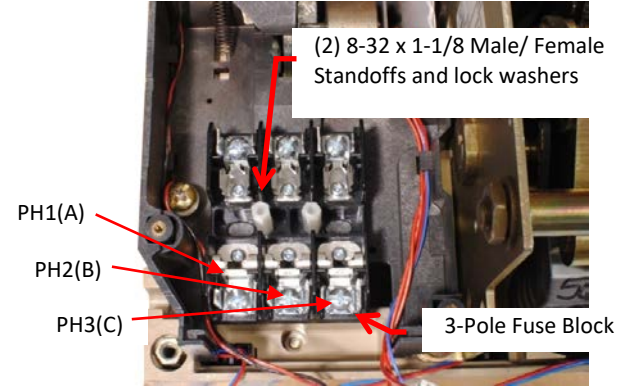

Fuse Block Installation (AC-PRO-MP-II only)

Run #20 AWG SIS wire from the 3-pole fuse block thru the breaker using the same path as the existing CT wires. Connect to the line side of the breaker existing screws as shown using the ring tongue terminals provided. Connect to the 3-pole fuse block using the ring tongue terminals provided. It is very important to maintain proper phasing.

NOTICE

It is VERY important to maintain the proper phasing of the voltage wiring

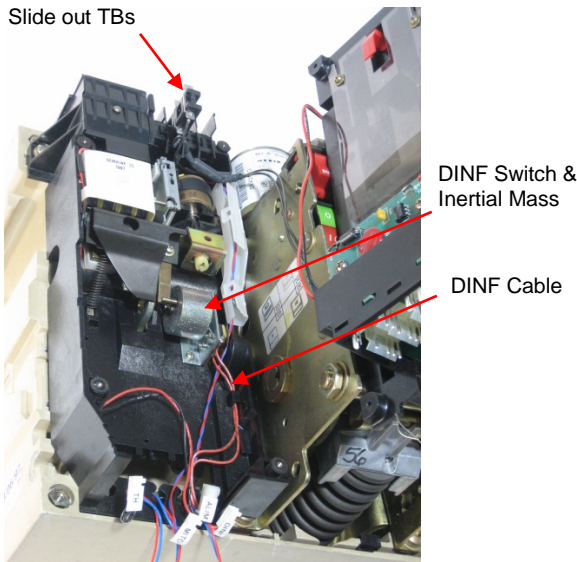

Slide out the three terminal blocks from the lower control unit.

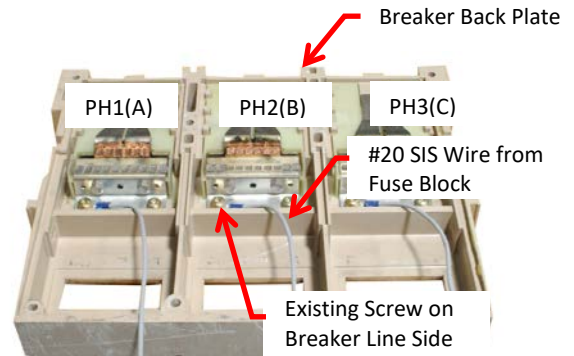

Fuse Block to Breaker Wiring (AC-PRO-MP-II)

Connect the wires from the rear of the trip unit to the 3-pole fuse block using the ring tongue terminals provided.

Install the three (3) T-306-4 Fuses (Buss KTK-R-1) into the 3-pole fuse block.

After the wiring to the 3-pole fuse block is complete, attach the fuse block cover to the 3-pole fuse block using two (2) 8-32 x 3/8 Phillips HD SEMS screws as shown.

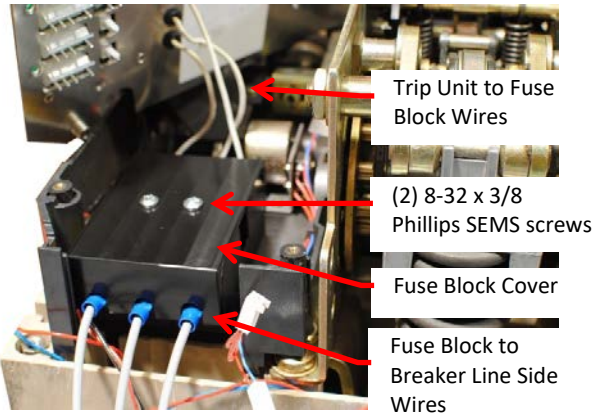

Trip Unit to Fuse Block Wiring (AC-PRO-MP-II)

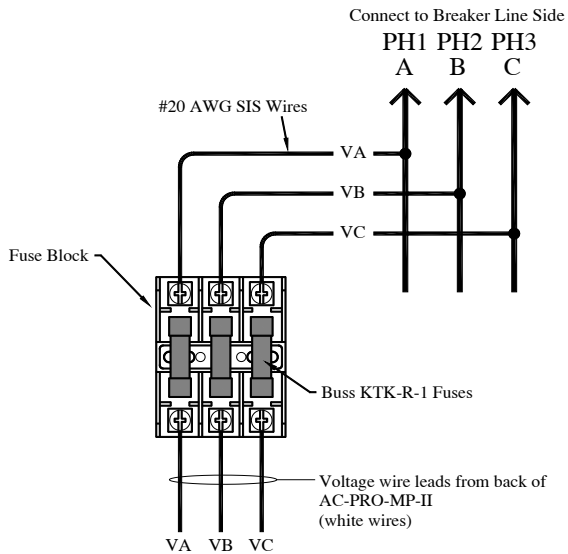

Voltage Connections Diagram (AC-PRO-MP-II)

3.5 Connect CT Connectors

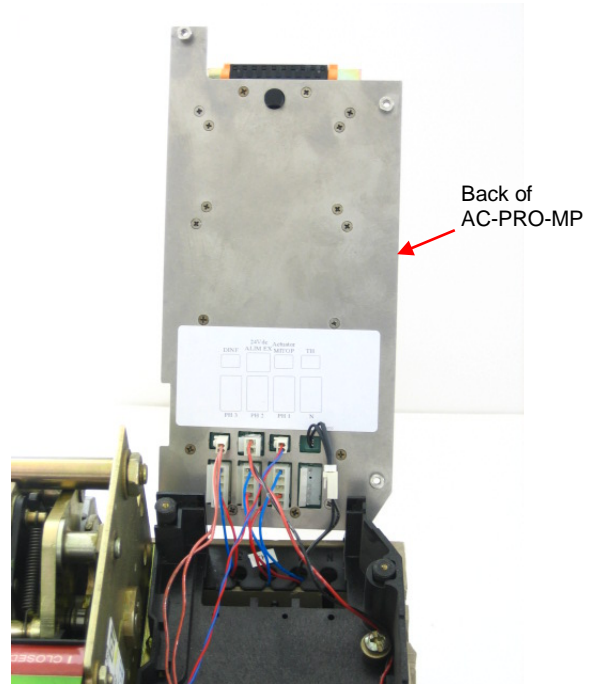

Connect the three (3) Phase CT connectors. Connect the Neutral CT connector if applicable. Connect the other connectors being very careful not to mix up the connectors. If necessary, use the extension cables for the TH and MTOP connections.

See the wire color codes in Section 3.2.

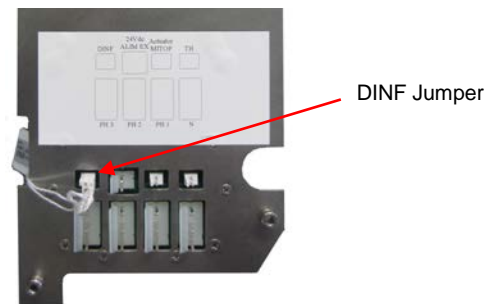

For those breakers that do not have a DINF Switch and inertial mass, leave the jumper in the DINF connector. Without the jumper DINF Instantaneous will always be on.

Otherwise, remove and discard the jumper and connect the DINF cable to the DINF connector.

3.6 Attach the AC-PRO-MP® to Breaker.



Set the AC-PRO-MP® in place and attach using four (4) M3 X 16 Phillips screws.

3.7 Check Alignment of “Push-to-Reset” Rod.

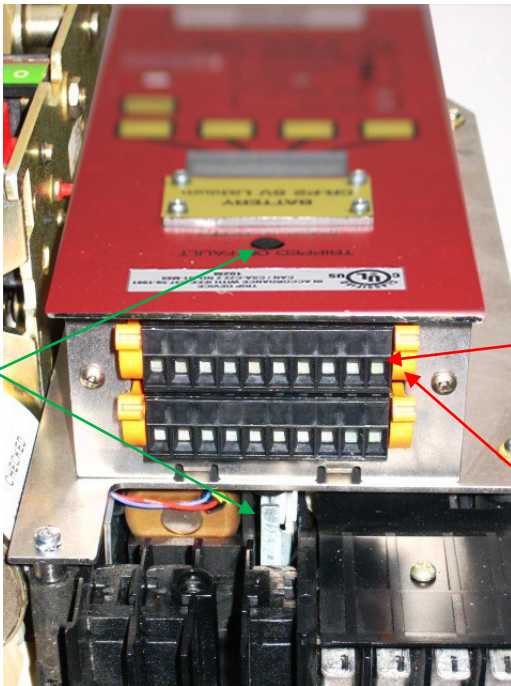

Check alignment with mechanism

Auxiliary Wiring connector shown without wires

Check for proper alignment of the back of the “Push-to-Reset” rod with the small reset piece in the lower control unit.

Insert Auxiliary Wiring connector in AC-PRO-MP

3.8 Auxiliary Wiring Connections.



Snap connectors out of 3 plastic terminal blocks

Snap the connectors out of the three (3) plastic terminal blocks. The plastic terminal blocks will be reused. Do not remove the Neutral CT terminals T1 & T2 if installed. See Auxiliary Terminal Block Wiring on next page.



Auxiliary Wiring Connector with Wires

Snap new connectors into the 3 plastic terminal blocks

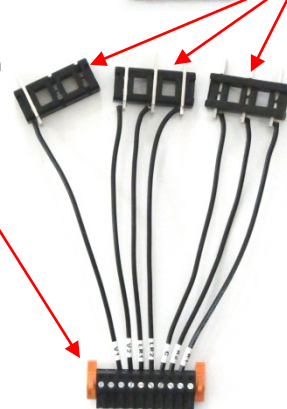

Snap the new terminals into the existing slide in plastic terminal blocks. Follow the connection diagram on Page 8. Make sure the terminals are fully seated in the plastic terminal blocks.

Insert the assembled auxiliary wiring connector into position on top of the AC-PRO-MP.

3.9 Insert the Auxiliary Terminal Blocks into the Lower Control Unit.

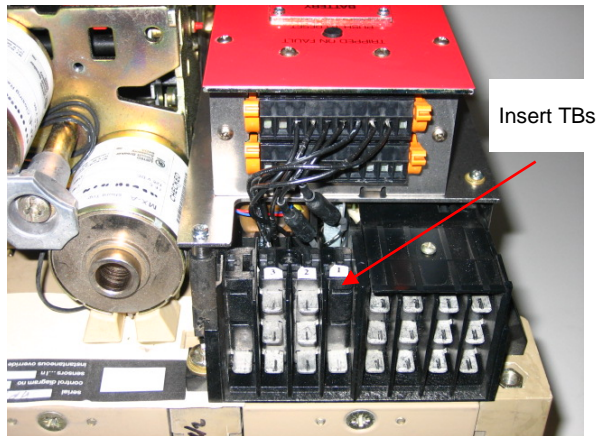

Insert the terminal blocks into their proper location in the lower control unit.

Follow the diagram below.

3.10 Modify and Install Terminal Block Cover.

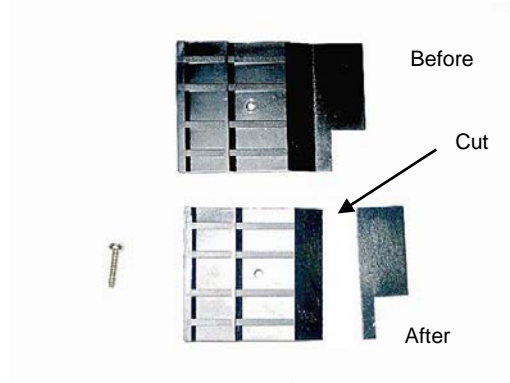

Cut off the bottom portion of the right terminal block cover previously removed.

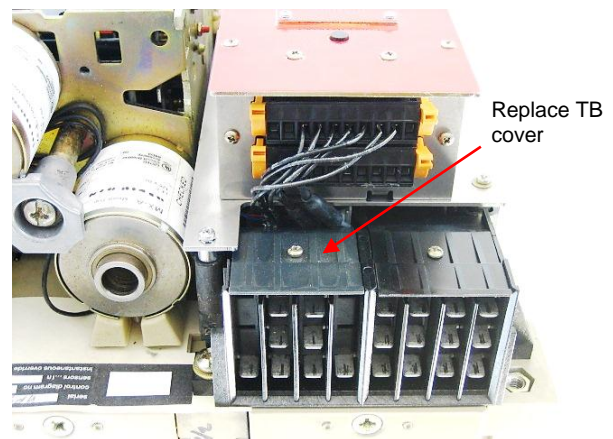

Replace the terminal block cover using the existing screw.

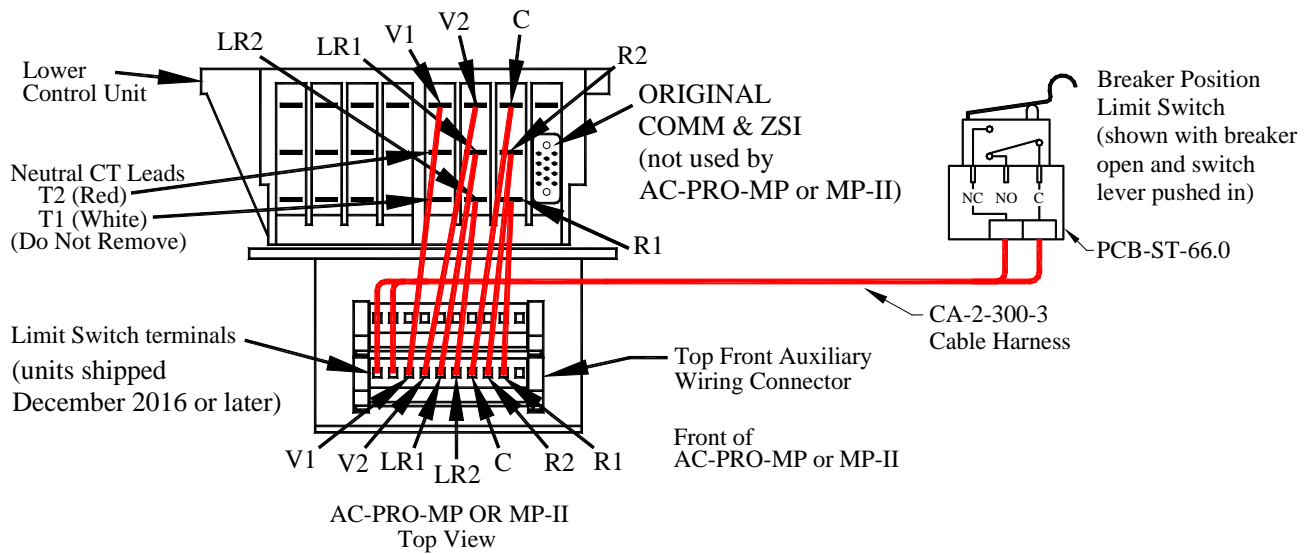

Auxiliary Terminal Block Wiring

3.11 Installing the Breaker Position Limit Switch

A limit switch is provided as a breaker position input, for AC-PRO-MP or MP-II trip units shipped in December 2016 or later.

This limit switch must be installed for the following:

- 1) To provide breaker open or closed information to the communications system.
- 2) To enable "SLUGGISH BREAKER" detection.

The patented "SLUGGISH BREAKER" detection feature measures the breaker mechanism operating speed for every trip operation initiated by the trip unit including the important "First Operation". If the mechanism operation time is longer than the programmed time, the trip unit will provide a **SLUGGISH BREAKER (MAINTENANCE REQUIRED)** alarm.

Install the limit switch on the breaker as follows:

Make sure the breaker is open.

The limit switch mounting bracket assembly mounts on the right side of the breaker mechanism using an existing hole in the breaker mechanism horizontal support plate. Slide the limit switch mounting bracket assembly onto the breaker mechanism horizontal support plate so that the support plate goes thru the gap in the bracket assembly as shown. Attach the bracket assembly to the support plate using one (1) 4-40 x 3/8 Phillips HD screw and lock washer.

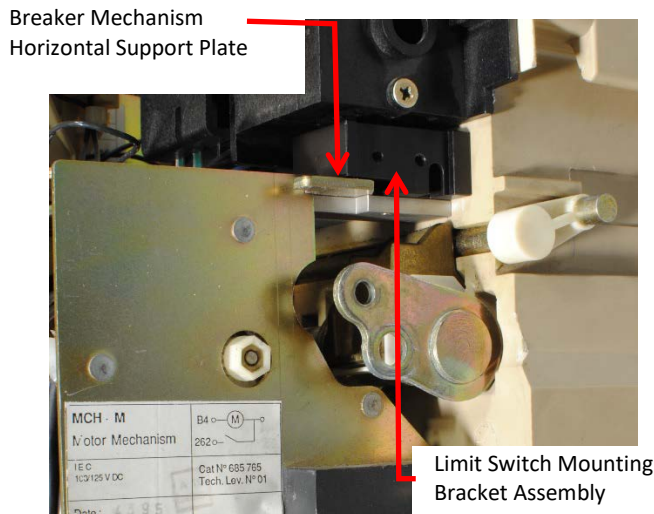

Limit Switch Mounting Bracket Installation

The breaker mechanism may have an existing connecting arm to the auxiliary contacts. Follow the appropriate instructions below for the breaker type being retrofitted.

If the breaker does NOT have an auxiliary contact connecting arm:

The limit switch flag mounts to an existing hole in the breaker mechanism. Place one (1) 6mm dia. x 6mm lg. Shoulder screw thru the hole and lock the shoulder screw in place using one (1) Nylon spacer, one (1) M6 lock washer and one (1) Black Delrin Rod as shown below. Securely tighten the flag assembly.

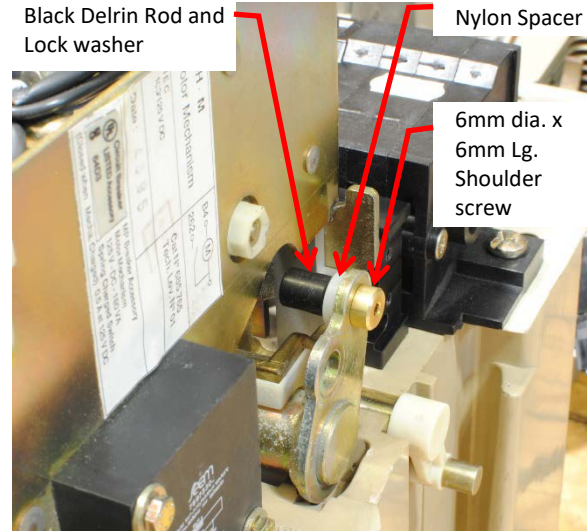

Limit Switch Flag Installation (breaker WITHOUT Auxiliary contact arm)

If the breaker DOES have an auxiliary contact connecting arm:

Remove the existing auxiliary contact connecting arm by removing the e-rings holding the arm in place.

Remove the pin from the end of the connecting arm that connects to the breaker mechanism and use a 6mm diameter drill to enlarge the hole in the end of the connecting arm that the pin was removed.

Reattach the connecting arm to the auxiliary contact using the existing e-ring.

The limit switch flag mounts in an existing hole in the breaker mechanism.

Place one (1) 6mm dia. x 6mm lg. Shoulder screw thru the hole in the breaker mechanism and the connecting arm. Lock the shoulder screw in place using one (1) M6 lock washer and one (1) Black Delrin Rod as shown. Securely tighten the flag assembly.

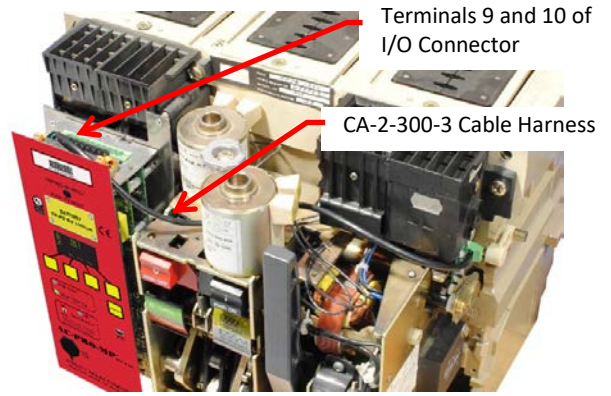
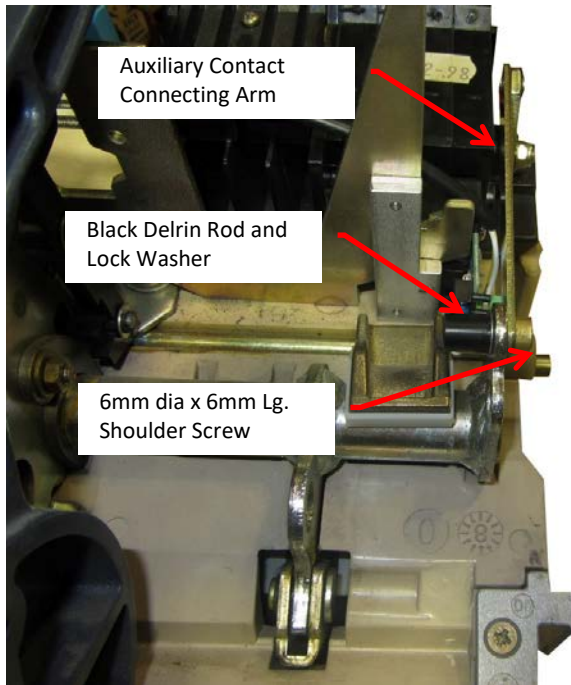

Limit Switch Wiring

**Limit Switch Flag Installation
(breaker WITH Auxiliary contact arm)**

Attach the limit switch circuit board to the mounting bracket assembly using two (2) 6-32 x 3/8 Phillips HD Cap screws and lock washers. See the photo.

Adjust the location of the circuit board left or right until the limit switch changes state or “clicks” against the limit switch flag. Securely tighten the hardware to hold the circuit board in location.

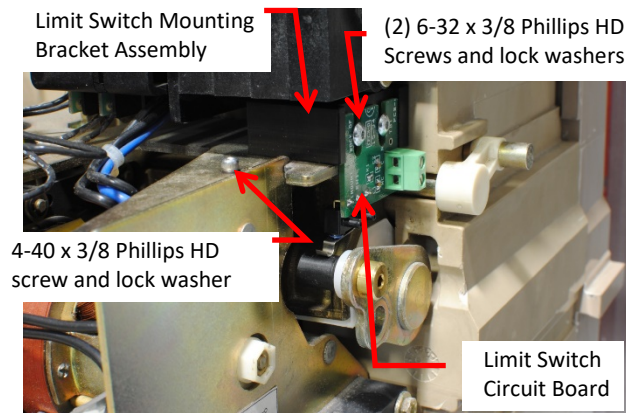

Limit Switch Circuit Board Installation

Wire the 2-pole terminal block on the limit switch circuit board to terminals 9 and 10 of the TRIP UNIT I/O connector as shown on page 8. Polarity is NOT important. Use the CA-2-300-3 Cable Harness provided with two (2) 22 AWG wires in a PVC tube.

3.12 Installing Communications Connections (AC-PRO-MP-II)

The AC-PRO-MP-II kit includes a 2-segment communications cable with quick disconnect, and a 3-point terminal block. The short segment of the cable is attached to the AC-PRO-MP-II harness that plugs into the trip unit. The other (longer) segment of the cable is attached to the 3-point terminal block in the switchgear cubicle. The quick-disconnect must be disconnected before the breaker is completely removed from the switchgear.

The communications cable will be routed through the top of the breaker as shown in the photos below.

Notch a 3/8" wide x 5/16" opening in breaker cover as shown in photo for communications cable clearance.

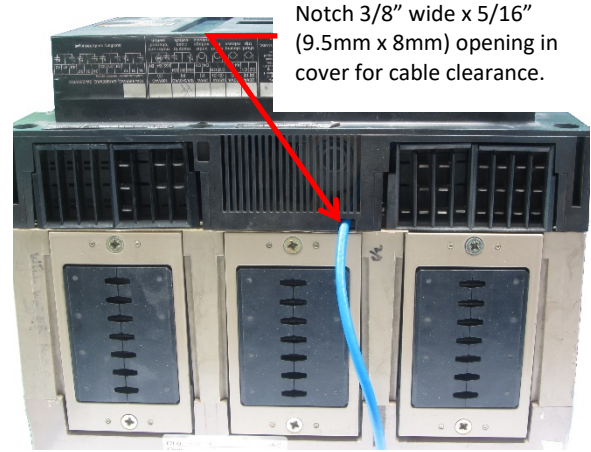

Communications Cable Installation (notch in top of breaker cover) (AC-PRO-MP-II)

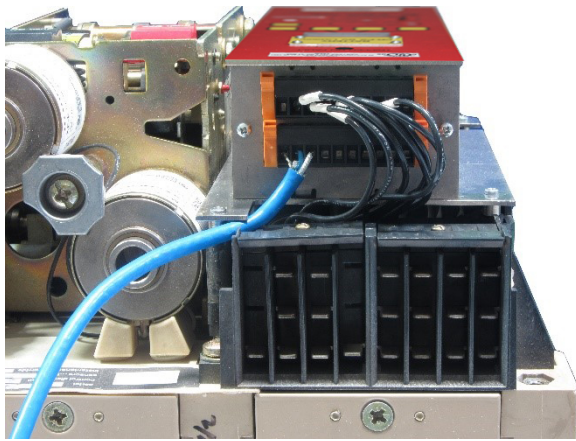

Communications Cable Installation (with cover removed) (AC-PRO-MP-II)

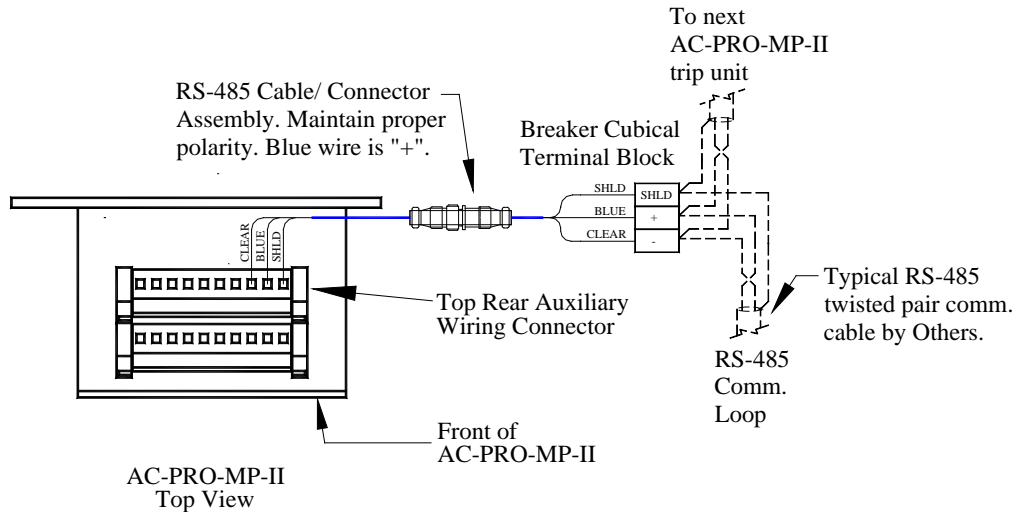

Communications Connections (AC-PRO-MP-II only)

3.13 Replace Breaker Front Cover.

Replace the breaker front cover using the existing hardware.

4.0 Settings

The trip unit is shipped un-commissioned and must be commissioned before placing in service.

The push buttons and display on the front panel or the USB Interface with a laptop computer can be used to make the initial settings or change existing settings.

**** IMPORTANT ****

The trip unit will NOT FUNCTION as it is shipped from the factory. The user must first COMMISSION the unit as outlined in this Section to make it functional.

4.1 Change Settings Using the Front Panel

Push the “DISPLAY” button to power up the trip unit. The following is displayed if the unit has not been commissioned yet:

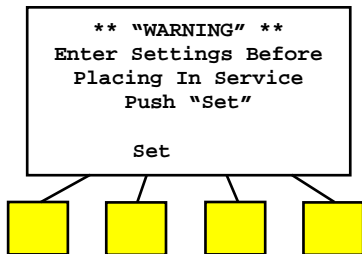

If the unit was already commissioned, the following screen will be displayed:

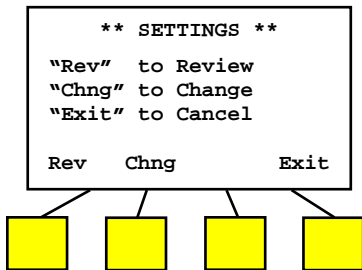

Push the “Set” button at the “**WARNING** – Enter settings” screen. Or push the “Chng” button at the “**SETTINGS**” screen to display the security window:

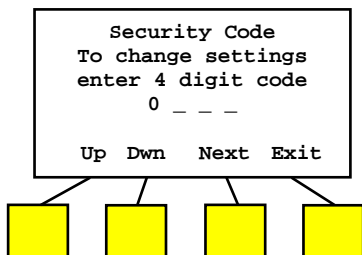

The Security Code is the last four (4) digits of the Serial Number. See Section 2.1 for the location of the Serial Number.

Push the “Up” or “Down” button to select the value of each digit.

Use the “Next” button to advance to the next digit.

For the last digit, the following is displayed:

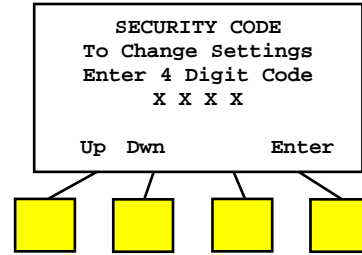

Push the “Enter” button after the last digit of the Security Code is entered.

The following is displayed:

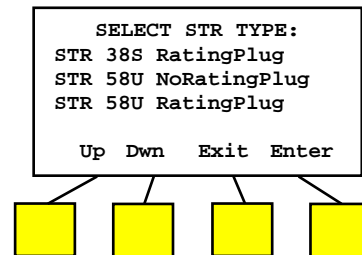

Push the “Up” or “Down” buttons until the desired STR trip unit type is flashing.

The other STR types are displayed by pushing the “Up” button several times.

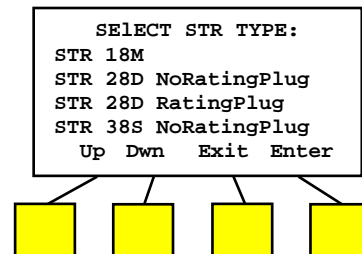

After pushing “Enter”, the following is displayed:

After pushing "Enter", the following is displayed:
(Not for 18M or 28D)

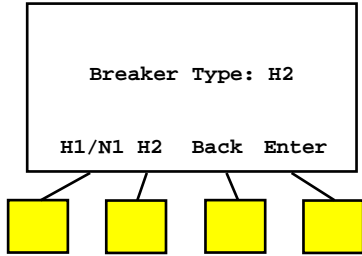

The H1/N1 breakers have standard or special interrupting rating and the H2 breakers have high interrupting rating.

After pushing "Enter", the following is displayed:

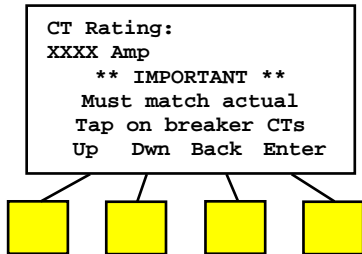

Use the "Up" and "Down" buttons to enter the correct CT Rating.

**** IMPORTANT ****
The CT Rating entered MUST match the rating of the CTs in the breaker.

After pushing "Enter", the following is displayed:
(Not for 18M or non-rating plug versions)

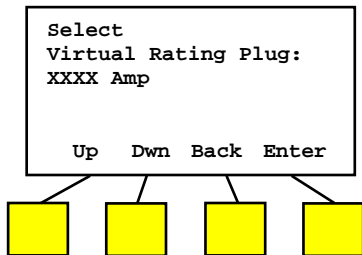

Use the "Up" and "Down" buttons to enter the desired Virtual Rating Plug rating.

After pushing "Enter", the following is displayed:
(Not for 18M)

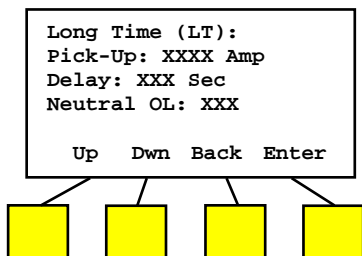

Use the "Up" and "Down" buttons to enter the desired Long Time Pick-Up (LTPU) value.

After pushing "Enter", use the "Up" and "Down" buttons to enter the desired Long Time Delay (LTD).

After pushing "Enter":

For trip units shipped in December 2016 or later:
The Neutral Overload Protection On/Off setting will appear: use the "On" and "Off" buttons that appear to turn Neutral Overload on or off. (does not apply to 18M). If Neutral Overload is turned on, "(Requires Neutral CT)" will appear.

For AC-PRO-MP trip units shipped before December 2016:

After setting the Long Time Delay, the next screen will be Short Time settings.

Next, for Short Time Settings, the following is displayed:
(Not for 18M or 28D)

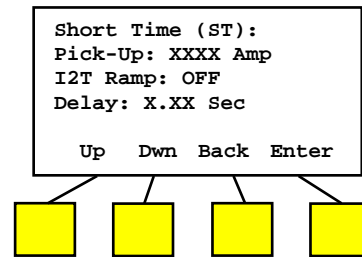

Use the "Up" and "Down" buttons to enter the desired Short Time Pick-Up (STPU) value.

After pushing "Enter", use the "On" and "Off" buttons that appear to enter I²T ramp on or off.

After pushing "Enter", use the "Up" and "Down" buttons to select the desired Short Time Delay (STD).

After pushing "Enter", the following is displayed:
(Not for 18M or 28D)

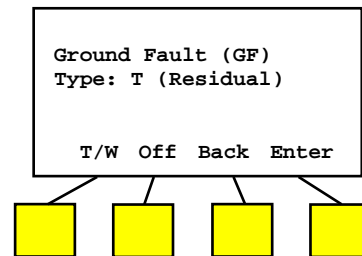

Use the "T/W" button to switch between the two types of Ground Fault protection.

"T" is for the normal 3-Wire or 4-Wire residual Ground Fault.

"W" is for source ground return Ground Fault.

Note: if type "W" is selected, Neutral Overload will automatically be turned OFF and "(Disables Neutral OL)" will be displayed.

After pushing “Enter”, the following is displayed:
(Not for 18M or 28D)

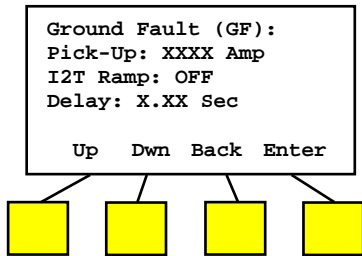

Use the “Up” and “Down” buttons to enter the desired Ground Fault (GFPU) Pick-Up value. The maximum GFPU is 1200 Amp.

A GFPU setting less than 25% of the CT rating requires 24Vdc external power.

After pushing “Enter”, use the “On” and “Off” buttons that appear to enter I²T ramp on or off.

After pushing “Enter”, use the “Up” and “Dwn” buttons to select the desired Ground Fault Delay (GFD).

After pushing “Enter”, the following is displayed:

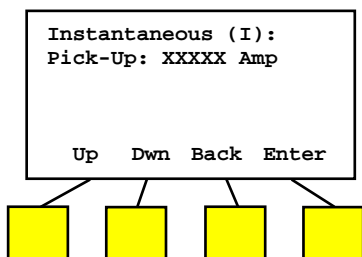

Use the “Up” and “Down” buttons to enter the desired Instantaneous Pick-Up (IPU) value.

After pushing “Enter”, the following is displayed:

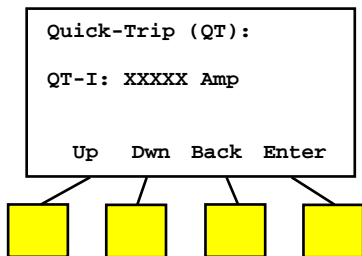

Use the “Up” and “Down” buttons to enter the desired QUICK-TRIP Instantaneous Pick-Up (QT-I) value. An off setting is not available.

After pushing “Enter”, the following is displayed:
(Not for 18M or 28D)

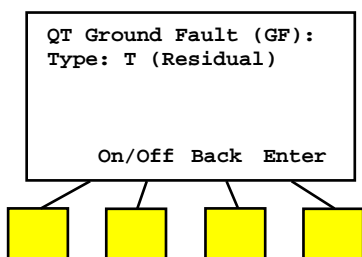

Use the “On/Off” button to toggle between “On” or “Off” for the QUICK-TRIP® Ground Fault function.

If the normal GF was previously set to “Off”, the following will be displayed instead of the above display.
(Not for 18M or 28D)

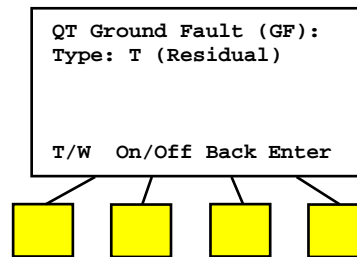

Use the “On/Off” button to turn the QUICK-TRIP® Ground Fault function on or off.

Use the “T/W” button to select the type of Ground Fault.

“T” is for the normal 3-Wire or 4-Wire residual Ground Fault.

“W” is for source ground return Ground Fault.

After pushing “Enter”, the following is displayed:
(Not for 18M or 28D)

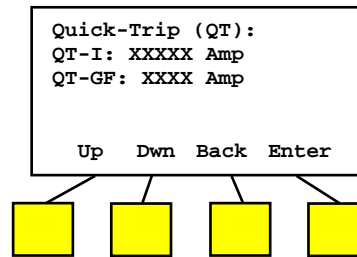

Use the “Up” or “Down” buttons to select the desired QUICK-TRIP Ground Fault (QT-GF) Pick-Up value.

A QT-GF setting less than 25% of the CT rating requires 24Vdc external power.

After pushing “Enter”, the following is displayed:
(Not for 18M, 28D or 38S)

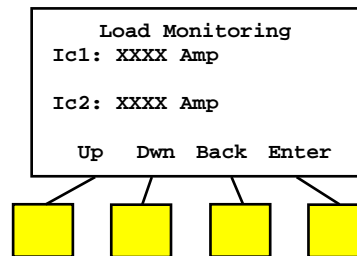

See Section 16.0 for more information on the Load Monitoring relays.

Use the “Up” or “Down” buttons to select the desired Load Monitoring 1 (Ic1) Pick-Up or scroll down to off.

Push the “Enter” button to go to Load Monitoring 2 (Ic2).

Use the “Up” or “Down” buttons to select the desired Ic2 Pick-Up or scroll down to off.

After pushing “Enter”, the following is displayed:

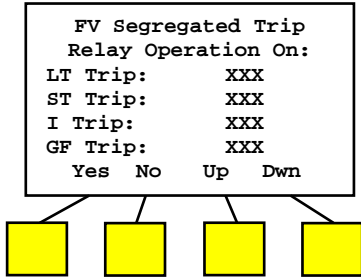

See Section 14.0 for more information on the FV Segregated Trip relay.

Use the “Yes” or “No” buttons to select which combinations of protective functions will operate the FV Segregated Trip Relay.

The FV Segregated Trip Relay requires 24Vdc external power to operate.

Use the “Down” button to move to the next function.

When the “Down” button is pushed after the “GF Trip” FV Segregated Trip Relay operation is selected, the following is displayed:

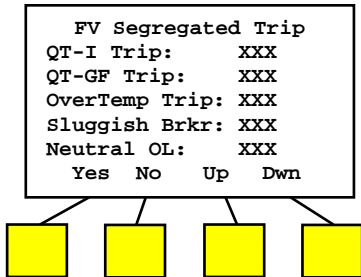

Use the “Yes” or “No” buttons to select which combinations of functions will operate the FV Segregated Trip Relay.

Use the “Down” button to move to the next function.

After setting the “Neutral OL” function, pushing the “Down” button will display the following: (this screen only applies to AC-PRO-MP-II)

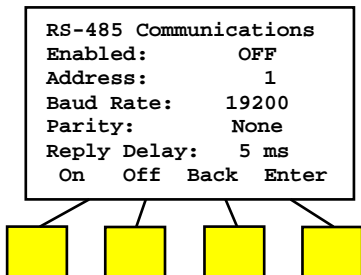

The AC-PRO-MP-II is capable of communicating over an RS485 network via Modbus RTU protocol. The RS485 communications settings are as follows:

Communications Enabled: Set to ON if RS485 communications will be used.

Address: Each trip unit that shares the same twisted pair must have a unique address. The address identifies each individual trip unit.

Note: two trip units can have the same Address as long as they are not connected to the network via the same twisted pair cable.

The address is selectable from 1 to 247, in increments of 1. In most applications, only addresses 1 through 32 will be used due to the limitations of RS485 communications.

Baud Rate should be selected to match the baud rate of the master communicating device (i.e. PC, gateway, etc.).

Parity should be set to match the parity of the master communicating device (i.e. PC, gateway, etc.).

Reply Delay is the minimum delay between the trip unit’s receipt of a Modbus packet and its reply. It can be set to 5 or 10 milliseconds.

After setting the Reply Delay, pushing the “Enter” button will display the following: (this screen only applies to AC-PRO-MP-II)

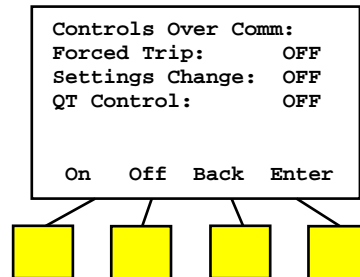

The AC-PRO-MP-II “Controls Over Comm” settings are locally set “permissive settings”, which should normally be set to OFF, unless there is a communications master device in place that is specifically intended and capable of performing these functions.

Forced Trip: If enabled, this feature permits tripping of the breaker via a forced trip command over RS485 communications.

Settings Change: If enabled, this feature permits the user to make settings changes via the communications network. Otherwise, settings can only be changed at the AC-PRO-MP-II using the smart buttons or using the local USB connection. NOTE: The CT settings can only be changed at the AC-PRO-MP-II.

QT Control: If enabled, this permits turning QUICK-TRIP settings ON over RS485 communications.

After setting QT Control, pushing the “Enter” button will display the following:

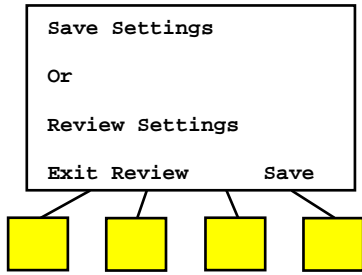

Pushing the “Review” button will review the settings just made and will allow changes to be made.

Pushing the “Save” button will save the settings into non-volatile memory and the following will be displayed for a short time:

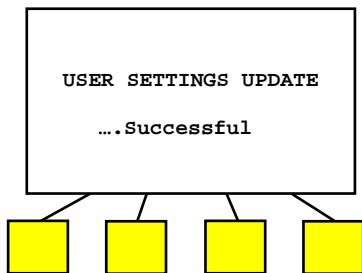

4.2 Reviewing Settings

The trip unit settings and information can be reviewed in a “read only” manner, using the Review Settings button.

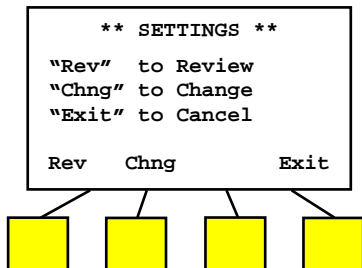

Push the “Rev” button at the “**SETTINGS**” screen to start reviewing the trip unit information and settings. After pushing “Rev”, the following will be displayed:

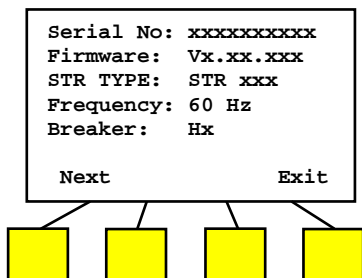

Push the “Next” button to continue reviewing trip unit settings. The subsequent screens will display all

settings, along with the “Next”, “Back”, and “Exit” buttons.

4.3 Setting the Time & Date

The AC-PRO-MP & MP-II include an internal clock that is powered by the 6V CR-P2 battery. The time and date setting is important, as trip events and on-demand waveforms are time stamped.

The time and date must be set after commissioning the trip unit or after replacing the battery

The clock does not automatically update for daylight savings time.

To view or change the time, push the “Display” button (and possibly the “Exit” button) to view the main screen:

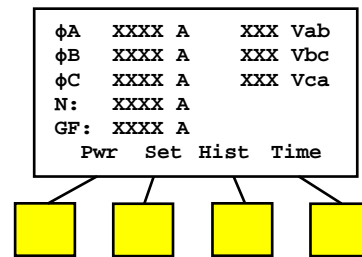

Push the “Time” button to display the time and date:

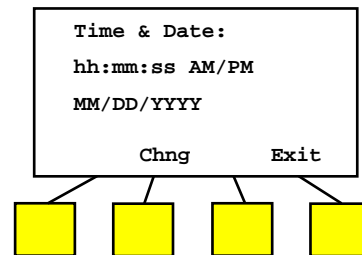

Where “hh:mm:ss” is the time of day in hour, minutes and seconds.

Where “MM/DD/YYYY” is the date in month, day and year.

To change the time, push the “Chng” button and follow the prompts.

4.4 Using the USB Interface

A USB 2.0, Mini-B connector on the front of the AC-PRO-MP & MP-II trip units is used to transfer information, including settings, between the trip unit and a computer, using InfoPro software. See Section 18.0.

The USB port also supports the SAFE-T-TRIP® remote hand-held device. See Section 7.0 for additional information.

5.0 Normal Operations & Readings

5.1 Current & Voltage Readings

During normal operation, the trip unit display screen will be off and in its power saving mode. When the "DISPLAY" button is pressed during normal operation (no trips, errors, alarms, etc), the trip unit will display currents and voltages. The voltages will be displayed if 24VDC control power is present, and if the voltage hardware is present. The neutral and GF currents will only be displayed if neutral or GF protective functions are turned on. See below. The "XXXX" digits will display actual readings.

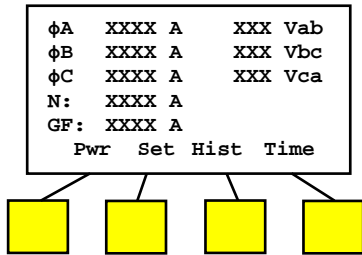

Main ("Readings") Screen
(voltages appear on AC-PRO-MP-II only)

- The left column displays Currents in Amps for Phases A, B, C, Neutral and Ground Fault.
- The right column displays Line-to-Line Voltages "Vab", "Vbc", and "Vca". These values appear for AC-PRO-MP-II only.

Breaker Current Less than 10% of CT Rating:

When the currents are less than about 10% of the CT rating, the display will display "LOW" for currents.

Breaker Current Greater than 10% of CT Rating:

If the breaker current is greater than about 10% of the CT rating, the current readings will be displayed.

Line-to-Line Voltages (if AC-PRO-MP-II and powered with 24VDC):

"LOW" will be displayed if the Line-to-Line voltage is 50V or below.

"N/A" will be displayed if the Voltage cannot be determined, most likely because system voltage (i.e. 480V) is not present at the AC-PRO-MP-II, or if 24VDC control power is not present.

The AC-PRO-MP-II is rated for up to 600V three-phase power systems.

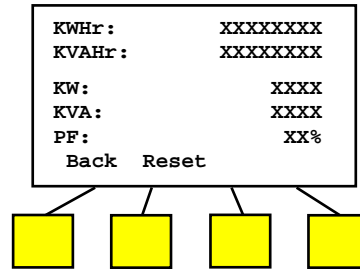

Power & Energy Screen
(AC-PRO-MP-II only)

5.2 Power and Energy Values
(AC-PRO-MP-II powered by 24VDC):

- KWHr = KiloWatt-Hours (real power usage)
- KVAHr = KiloVolt-Ampere-Hours (apparent power usage)
- KW = KiloWatts (instantaneous real power)
- KVA = KiloVolt-Amperes (instantaneous apparent power)
- PF = total instantaneous Power Factor
- "LOW" is displayed for the per-phase KW and KVA values if an associated phase current or voltage is "LOW".
- "N/A" will be displayed for KW and KVA values if the Voltage on the associated phase cannot be determined, most likely because system voltage (i.e. 480V) is not present at the trip unit, or 24VDC is not available.
- Energy values increment if the current for a particular phase is above 3% of the CT rating and the phase voltage is above 50V.
- The KWHr value increments (up) and decrements (down) depending on the power flow direction.
- The KVAHr value only increments (up).
- Note: Energy values can increment (up) even when the Instantaneous Power values displayed are "LOW"

6.0 QUICK-TRIP Arc Flash Reduction

The QUICK-TRIP® system (patents 7,646,575 & 7,889,474) is a manually controlled arc flash hazard reduction system. It can reduce trip times when turned on and allows selective coordination between circuit breakers when turned off.

If maintenance personnel must work on energized equipment, they will first turn the QUICK-TRIP system on at the breaker feeding the equipment. If a fault now occurs, the upstream breaker will trip quickly based on the QUICK-TRIP settings **reducing the Arc Flash Hazard to personnel.**

When the work is finished, the QUICK-TRIP® system is turned off and the original selective coordination is back in effect.

When QUICK-TRIP® is **on**, the following settings are enabled:

- QUICK-TRIP Instantaneous (QT-I)
- QUICK-TRIP Ground Fault (QT-GF)

All other settings remain in effect.

The “QUICK-TRIP ON LED” provides positive indication that the QUICK-TRIP settings are active if the LED is on.

**** IMPORTANT ****

A qualified engineer must determine the QUICK-TRIP® settings, calculate the incident energy levels and determine the Hazard Risk Categories (HRC) with QUICK-TRIP® both on and off.

6.1 QUICK-TRIP® Switch

The QUICK-TRIP switch on the front of the AC-PRO-MP can be used to turn the QUICK-TRIP functions on or off.

J. QUICK-TRIP on/off Switch

Move this switch to the on position to make the QT-I and QT-GF functions active for reduction of arc flash hazard.

K. Red QUICK-TRIP on LED

When this LED is on, the QT-I and QT-GF functions are active because either the local (J) or remote QUICK-TRIP switch is in the on position.

If the trip unit is not powered-up because of low breaker current and no 24Vdc auxiliary control power to the breaker, the QUICK-TRIP on LED will not be illuminated with the switch in the on position.

To verify that the QUICK-TRIP function will be active as soon as the trip unit powers up with breaker current, push the “Display” button (E) to power the trip unit using the battery. The QUICK-TRIP on LED will illuminate.

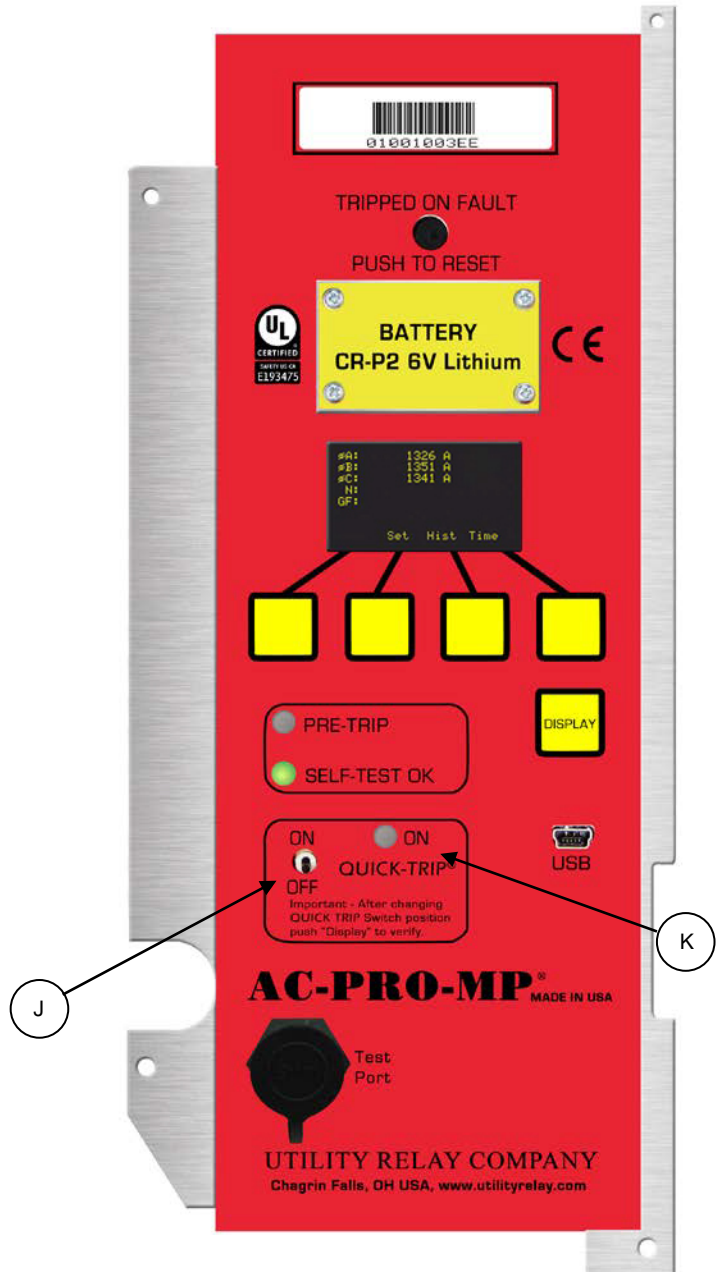

6.2 Remote QUICK-TRIP®

The QUICK-TRIP system can also be controlled remotely.

Either the local QUICK-TRIP switch on the front of the AC-PRO-MP or MP-II or the remote QUICK-TRIP switch/function can turn on QUICK-TRIP. Both must be in the off position to turn QUICK-TRIP off.

Remote QUICK-TRIP indication is also possible. This lamp will be energized whenever QUICK-TRIP is on, either by the local on/off switch or the remote QUICK-TRIP switch/function.

NOTE: Hardwired remote QUICK-TRIP is not available in the AC-PRO-MP & MP-II units with the front test port (shipped December 2016 and later).

For trip units sold in December 2016 or later:

Remote QUICK-TRIP control and indication can only be accomplished using Modbus Communications with AC-PRO-MP-II. For details see the AC-PRO-MP-II Modbus Communications Register Map.

Note: The “QT Control over Comm” (permissive) setting must be enabled at the trip unit locally before Remote QUICK-TRIP over communications can be utilized.

For AC-PRO-MP trip units sold prior to December 2016:

Remote QUICK-TRIP is accomplished with wiring, as shown in the diagram below. The remote indication lamp must use 150 milli-Amp or less current. A 40 to 125 Volt, AC or DC source is required for the remote QUICK-TRIP switch and the remote indication lamp. Connections for the remote QUICK-TRIP switch and the remote indication lamp are made to the remote QUICK-TRIP connector on the top of the AC-PRO-MP.

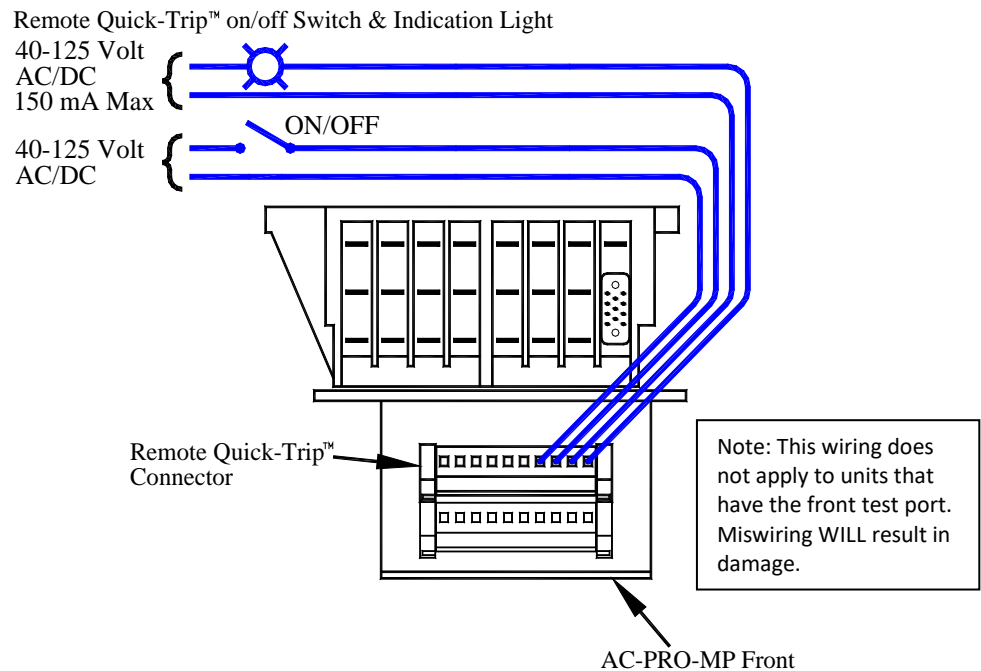

**Remote QUICK-TRIP wiring
 (only applies to units shipped prior to December 2016)**

7.0 SAFE-T-TRIP

The SAFE-T-TRIP remote hand-held trip device allows an operator to trip open a breaker without standing in front of the breaker. It also provides a way to obtain the breaker mechanism operation speed for the important **first operation**. This is accomplished using the patented SLUGGISH BREAKER Detection feature in the AC-PRO-MP and MP-II.

The SAFE-T-TRIP device is furnished with a permanently connected USB cable, allowing the breaker to be tripped without standing directly in front of the breaker, thus reducing the arc flash hazard risk.



The SAFE-T-TRIP device should not be operated while standing in front of a racked in breaker or breaker cubicle. The SAFE-T-TRIP is supplied with a 9V lithium battery, the attached USB cable with magnetic cable wrap, and instructions, in a durable, waterproof case.



SAFE-T-TRIP



SAFE-T-TRIP in case

8.0 SLUGGISH BREAKER Detection

The AC-PRO-MP and MP-II feature a patented SLUGGISH BREAKER Detection feature that captures the breaker mechanism time when a trip occurs that was initiated by the trip unit. If the breaker mechanism time is in excess of 33 milli-seconds, an alarm message will appear after the “Display” button is pressed. Also, the FV segregated trip relay can be set to operate if a SLUGGISH BREAKER Detection trip occurs. See the alarm message below:

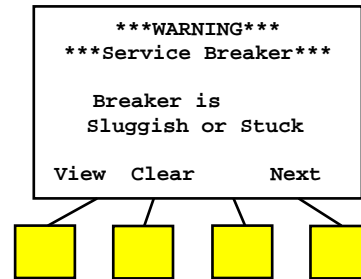

If a “sluggish” trip occurs, breaker mechanism maintenance is required.

Press “View” to view the breaker clearing times. See Section 9.0.

Press “Clear” to clear the SLUGGISH BREAKER Detection alarm message after maintenance is performed.

Pressing “Next” will advance to the next alarm screen if additional alarms are present, or it will advance to the Main readings screen if no additional alarms are present.

When the AC-PRO-MP & MP-II send a trip pulse to the breaker actuator, the SLUGGISH BREAKER Detection timer starts.

Units shipped prior to December 2016 use the zero current method. The trip unit determines the breaker clearing time by monitoring the current values. The SLUGGISH BREAKER Detection timer stops when the current is zero. The breaker clearing time for each breaker pole is recorded.

Units shipped in December 2016 and later use the limit switch method. The trip unit determines the breaker clearing time by monitoring the breaker position limit switch (which was supplied with the AC-PRO-MP or MP-II retrofit kit). The SLUGGISH BREAKER Detection timer stops when the limit switch input to the trip unit changes state, confirming the breaker is fully open. One breaker clearing time is recorded.

**** IMPORTANT ****

24VDC auxiliary control power or a fresh battery must be present to guarantee the breaker clearing time is captured.

9.0 Last Trip Data

Push the "Display" button to power up the trip unit. The following is displayed:

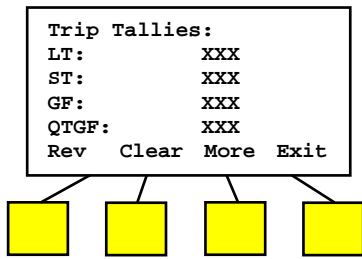

Push the "More" button to display the remaining trip functions:

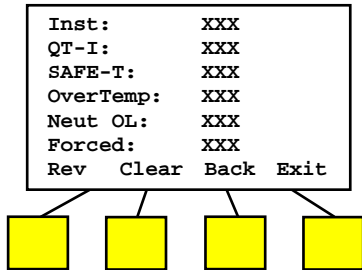

Pushing the "Clear" button will start the procedure to clear all the last trip data.

Pushing the "Review" button to review the details of the latest trip:

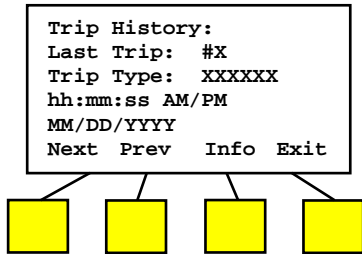

Where "hh:mm:ss" is the time of day of this trip in hour, minutes and seconds.

Where "MM:DD:YYYY" is the date of this trip in month, day and year.

Push the "Previous" button to display the prior trip.

Push the "Information" button to display the detailed information of the Phase, neutral & ground fault currents for this trip:

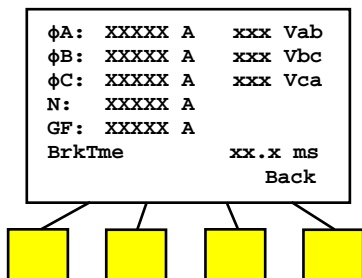

The trip history data can be viewed, saved, and printed using the InfoPro software application. Refer to Section 18.0 for more information.

For units shipped in December 2016 or later, waveforms are captured for the last 8 trips. These waveforms can be viewed with InfoPro-MP-II. Additionally, AC-PRO-MP-II units communicate trip data via RS-485 Modbus RTU communications.

****** IMPORTANT ******

24VDC auxiliary control power or a fresh battery must be present to ensure the breaker clearing time and waveform data is captured.

A fresh battery must be in place to maintain accurate clock time and for accurate date/time stamps in Trip History.

10.0 Replacing the Battery

The battery can be easily replaced.

Remove the four (4) 2-56 screws attaching the battery cover.



Remove (4) 2-56 Screws



Remove the old battery and install a new CR-P2, 6 Volt Lithium battery. Replace the battery cover.

11.0 Self-Test Feature

The AC-PRO-MP and AC-PRO-MP-II continually perform self tests in the background.

If an internal problem is detected, the “Self Test OK” LED is turned off.

The internal self tests include:

- Watch dog timer
- Memory check sum
- Memory access error
- Low battery voltage
- Actuator connected
- Setting problem

12.0 Primary & Secondary Injection

12.1 Primary Injection Testing

A primary injection test is recommended as the final test of the AC-PRO-MP or MP-II. This tests the complete system.

If Ground Fault with the “T” option (residual) is used, GF must be temporarily turned off when single phase testing the other trip functions with a primary injection test set.

12.2 Secondary Injection Testing

The AC-PRO-MP secondary injection test set provides a quick and easy way to test the AC-PRO-MP and AC-PRO-MP-II trip units.

The test set performs a true test of each Phase and can also test the Ground Fault function.

For units shipped prior to December 2016: The test set harness plugs into a port on the left side of the trip unit.

For units shipped in December 2016 and later: The test set harness plugs into a port on the front of the trip unit.

The same test set can be used for all AC-PRO-MP and MP-II trip units. If you do not have a test set harness for trip units that have a front test port, contact Utility Relay Company.

Refer to the MP Test Set Instruction Manual for testing instructions and information.

For the latest version, visit:

http://www.utilityrelay.com/Side_Bar/Instruction_Manuals.html

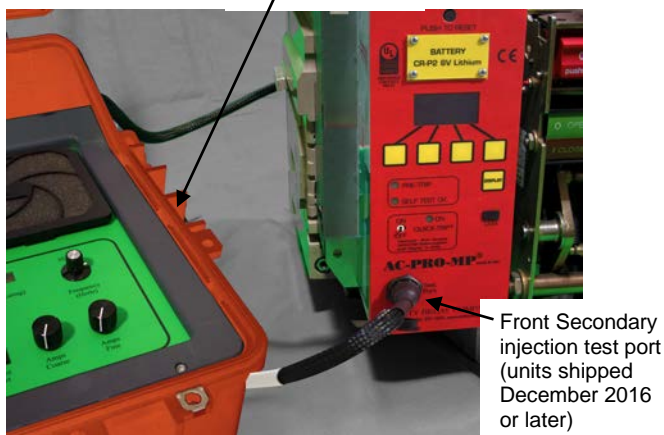
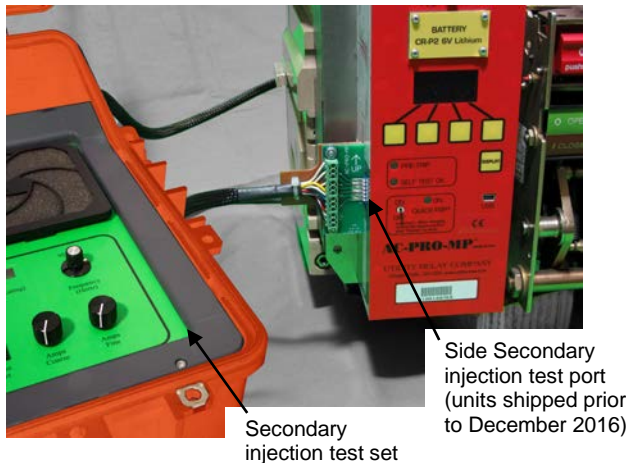

13.0 DINF Instantaneous Trip

Some Masterpact MP breakers have a DINF Instantaneous (DINF-I) feature. The DINF-I trip function is only enabled for a short time while the breaker is closing. After the breaker is fully closed and latched, the DINF-I trip function is disabled by the DINF micro-switch.

The DINF-I function is controlled with a micro-switch and inertial mass. They are located in the lower control unit as shown in Section 3.3. The connection to the AC-PRO-MP or MP-II trip unit is via connector "A" as shown in in Section 2.2.

Not all Masterpact MP breakers are equipped with the DINF micro-switch and, therefore, the DINF-I trip function is never active.

The DINF-I Pick-Up settings are fixed depend on the CT rating as shown below.

CT Rating (Amp)	DINF-I Pick-Up (Amp)
200	2200
250	2700
320	3400
400	4300
500	5400
600	6500
630	6800
800	8600
1000	10,800
1200	12,900
1250	12,900
1600	16,700
2000	20,800
2500	26,900
3000	32,300
3200	19,200
4000	24,000
5000	30,000
6000	36,000
6300	37,800

The DINF-I Pick-Up setting is not adjustable and is also not shown on the OLED display.

If the breaker does NOT have a DINF cable, leave the DINF jumper in place. See Section 3.5. Without the DINF jumper, DINF Instantaneous will always be on.

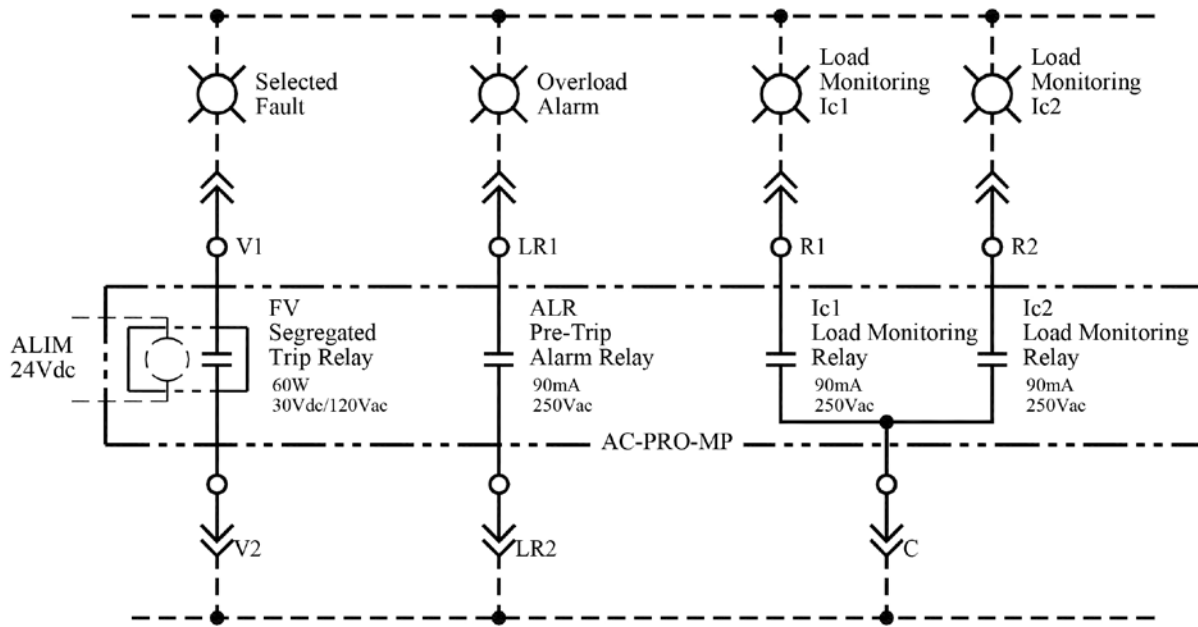

FV, ALR, Ic1 and Ic2 Wiring

14.0 FV Segregated Trip Relay

The FV Segregated Trip relay is a latching relay that is latched when a trip event occurs that is programmed to operate this relay.

None or one or more of the following trip events can be programmed to latch this relay:

- Long Time
- Short Time
- Instantaneous
- Ground Fault
- QUICK-TRIP Instantaneous
- QUICK-TRIP Ground Fault
- Over Temperature
- SLUGGISH BREAKER

If the FV Segregated trip relay is latched by a programmed trip event, it will stay latched until the next time the “Display” button is pushed. The operator then has the option to un-latch the relay as shown below:

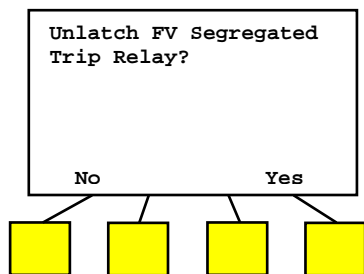

The FV Segregated Trip Relay requires 24Vdc external power to operate. The FV Segregated trip relay contact is normally open and is brought out to terminals V1 & V2 as shown in the wiring diagram on Page 8 as well as above.

15.0 ALR Pre-Trip Alarm Relay

The ALR Pre-Trip alarm relay signals the fact that the breaker current is greater than 105% of the Long Time Pick-Up setting. This indicates that a Long Time overload trip is in process.

When the breaker current drops below 105% of the Long Time Pick-Up setting or a trip occurs, the relay is de-energized and the contact opens.

The ALR Pre-Trip alarm relay contact is normally open and is brought out to terminals LR1 & LR2 as shown in the wiring diagram on Page 8 as well as above.

16.0 Ic1 & Ic2 Load Monitoring Relays

If the STR 58U version is selected, the load monitoring relays Ic1 and Ic2 are active. These are independent relays that can be used for load shedding or alarms.

These relays have independent pick-up and time delay settings as shown in the TCC in Section 21.6.

Once energized, the relays stay energized until the breaker trips or for 10 seconds after the breaker current drops below the pick-up setting.

The Ic1 relay contact is normally open and is brought out to terminal R1. The Ic2 relay contact is also normally open and is brought out to terminal R2. Both relays share the “C” common output as shown in the wiring diagram on Page 8 as well as above.

17.0 Communications

Creating a complete power monitoring and communications system for a low voltage power distribution system is easy with AC-PRO-MP-II. The standard AC-PRO-MP-II trip unit communicates using industry standard Modbus RTU protocol through a single shielded twisted pair wire connected to the RS485 port. A number of trip units can be daisy-chained together to simplify installation.

AC-PRO-MP-II communications features and information:

- Currents, 3-phase
- Review and change all settings (“Changing settings over Comm” user setting must be enabled at trip unit).
- Voltages, 3-phase
- KW, total
- KWHr, total
- KVA, total
- KVAHr, total
- Power Factor data
- Breaker position status (open or closed)
- Trip unit alarms and status information
- Sluggish-Breaker indication
- QUICK-TRIP ON /OFF status
- Trip unit time and date
- Trip unit Information: serial number, firmware revision.
- Forced trip (“Forced trip over Comm” user setting must be enabled at trip unit).
- Trip history data for the last 8 trips
 - Trip counts
 - Trip type (reason for trip)
 - Trip dates & timestamps
 - Trip currents & voltages
 - Breaker clearing times

A host PC running HMI software with Modbus device drivers collects information from the trip units. The driver interrogates each trip unit individually and reports that information back to the host PC applications on a continual basis. Additional trip units can be added to the system by simply providing the new trip unit’s ADDRESS to the HMI software.

AC-PRO-MP-II trip units are compatible with the Modbus RTU communication protocol supplied with most HMI systems.

Note: 24VDC control power is required for communications.

17.1 Communications Components

An AC-PRO-MP-II Modbus Communications system consists of the following hardware components:

1. AC-PRO-MP-II trip unit and breaker retrofit components.
2. Host PC (supplied by others).
3. Cabling topology (supplied by others).

Additional components to consider include:

1. OPC software with Modbus device drivers (supplied by others).
2. Modbus RTU/Ethernet converter (supplied by others).
3. Human-Machine Interface (HMI) System (supplied by others). These systems are used to view trip unit information graphically and often contain their own compatible Modbus Driver.

17.2 Communications Wiring

All AC-PRO-MP-II trip units are furnished with quick-disconnect communications cable assemblies. The cable assembly features a heavy-duty twist-lock connector and a terminal block, which mounts inside the switchgear.

The purpose of the terminal block is to provide a connection location for the twisted pair wire as it is daisy-chained from cell to cell in a switchgear lineup. This enables any individual communicating AC-PRO-MP-II (mounted on a circuit breaker) to be removed without disrupting communications between the other communicating AC-PRO-MP-II trip units.

17.3 System Components & Computer Hardware

AC-PRO-MP-II communicates over the RS485 interface at 9600 or 19200 Baud, with 8 data bits, 1 stop bit and no parity using the Modbus RTU communications protocol.

17.4 Ethernet

With the addition of an RS485 to Ethernet Converter an existing Local Area Network (LAN) can be used to carry data between trip units and the PC. Converters are widely available from a variety of industrial manufacturers.

RS485 to Ethernet Converters are designed to be compatible with a TCP/IP network environment and typically connect to a LAN using standard 10Base-T modular CAT-5 cabling. These converters offer a relatively inexpensive means of connecting to a LAN.

17.5 Modbus Communications Register Map

The AC-PRO-MP-II Modbus Communications Register Map is included in a separate document. This document can be found at the web page below: http://www.utilityrelay.com/Side_Bar/Instruction_Manuals.html

17.6 Communications Settings

Refer to Section 4.1 for information about Communications settings.

18.0 InfoPro Software

InfoPro-MP a software application that can be used with AC-PRO-MP units that shipped prior to December 2016. It offers the following capabilities:

- Settings – upload, download, view, and save.
- Trip unit info: serial number, firmware versions, breaker name.
- Firmware updates

InfoPro-MP-II software is for AC-PRO-MP & MP II units that shipped in December 2016 or later (these units can easily be identified by their front test port). In addition to the above features, InfoPro-MP-II includes the following:

- Waveform capture ***
(on-demand and for the last 8 trips)
- Current readings
- Voltage, power, & energy readings
(AC-PRO-MP-II only)

***24VDC auxiliary power or fresh battery required for trip waveforms and clearing times. Fresh battery required for timestamps.

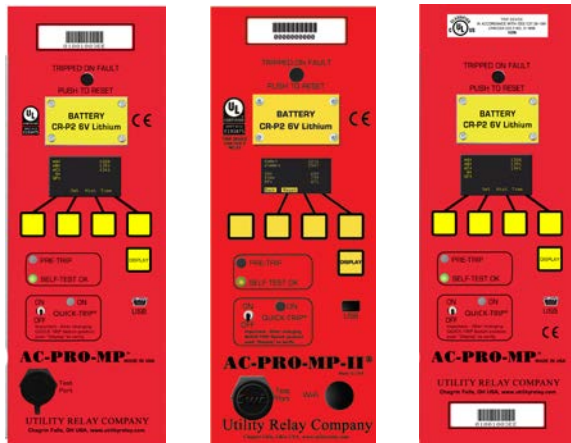

AC-PRO-MP
with front test
port (shipped
December 2016
or later)

AC-PRO-MP-II
with front test
port (released
December 2016)

AC-PRO-MP
(shipped prior
to December
2016)

Operating System:

Microsoft Windows, ideally Windows 7,
Windows 8, Windows 10 or Windows Vista.

Connection:

mini-USB (cable not included)

The InfoPro software applications are available for
download at:

http://www.utilityrelay.com/Side_Bar/Downloads.html



Open the downloaded file and follow the instructions
to install the application.

**** IMPORTANT ****

InfoPro software needs the correct USB device
driver to communicate with AC-PRO-MP and MP-II
trip units. Microsoft Windows often already
includes these drivers. However, if this driver is not
already installed:

- 1) Ensure your PC is connected to the Internet.
- 2) Connect the trip unit to your PC with the
USB cable.
- 3) Automatic driver update process:
 - a) After you connect the trip unit, if you
have an internet connection and
administrative rights on your PC,
Microsoft Windows should install the
driver automatically after a few
minutes.
- 4) Manual driver update process:
 - a) Open Windows Device Manager
 - b) Right click on the trip unit device. It
will be located under Ports or under
Other Devices.
 - c) Choose the “Update Driver Software”
option.
 - d) Choose the “Search automatically”
option.
 - e) After the driver is installed, close and
then reopen the InfoPro Application.

NOTE: Any pending Microsoft Windows updates
can interfere with the driver installation process.

For more detailed instructions with screenshots,
contact URC.

Refer to the InfoPro Help Guide within the application
for specific information and instructions.

18.1 Firmware Updates

To determine which firmware version is currently
installed on your trip unit, use the Settings menu. See
Section 4.2.

The InfoPro application can be used to update
firmware in the field using the USB port.
Firmware update instructions can be found in the
InfoPro Help Menu.

Note: Units with the front test port (shipped December
2016 or later) accept different firmware than units
shipped prior to December 2016.

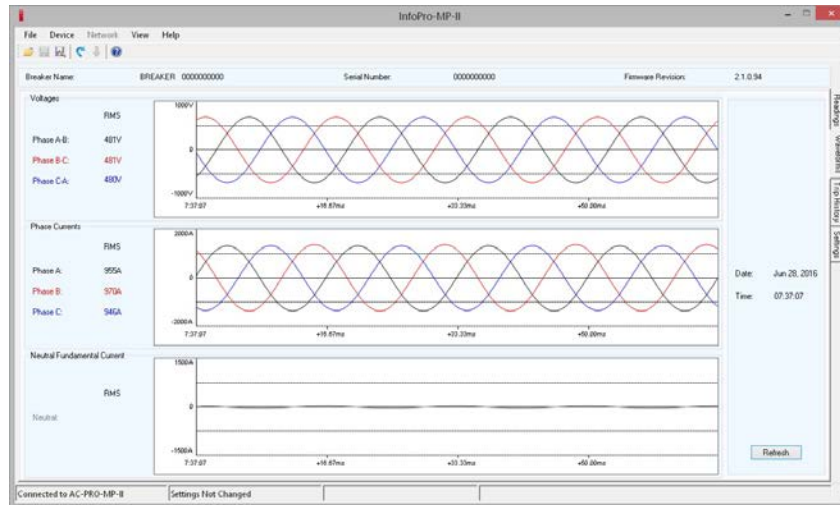

InfoPro-MP-II Waveform Tab Screenshot

19.0 Warranty

The AC-PRO-MP & AC-PRO-MP-II have a conditional 2-year warranty.

Please view the warranty page at the beginning of this manual for the full details.

Visit www.UtilityRelay.com or call 888-289-2864 for the latest information.

21.0 Time Current Curves

The pages to follow include the Time Current Curves for the AC-PRO-MP and AC-PRO-MP-II

20.0 Environmental Ratings

Ambient Temperature:

Trip Unit Electronics:

-4°F (-20°C) to 158°F (70°C)

OLED Display:

-22°F (-30°C) to 158°F (70°C)

Battery:

-4°F (-20°C) to 140°F (60°C)

Humidity:

95% non-condensing

Conformal Coating:

Acrylic conformal coating,

HumiSeal type 1A33

UL Component File #E105698

Enclosure:

14 Gauge, type 304 stainless steel

Battery:

Panasonic CR-P2

6 Volt, 1400 mAh Lithium

Non-Rechargeable

21.1 STR-18M Time-Current-Curve

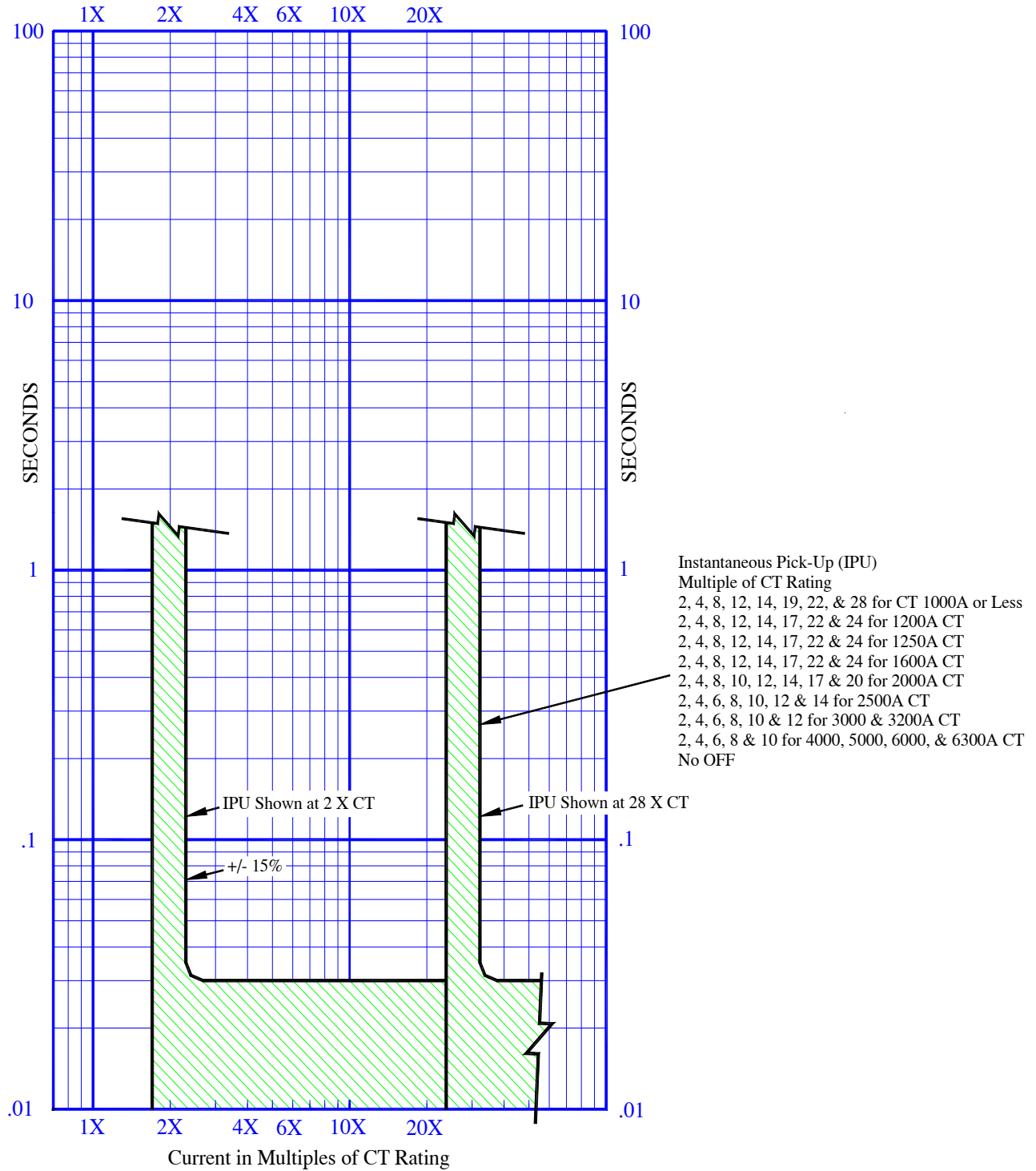

AC-PRO-MP & AC-PRO-MP-II with STR-18M setting

21.2 STR-28D Time-Current-Curve

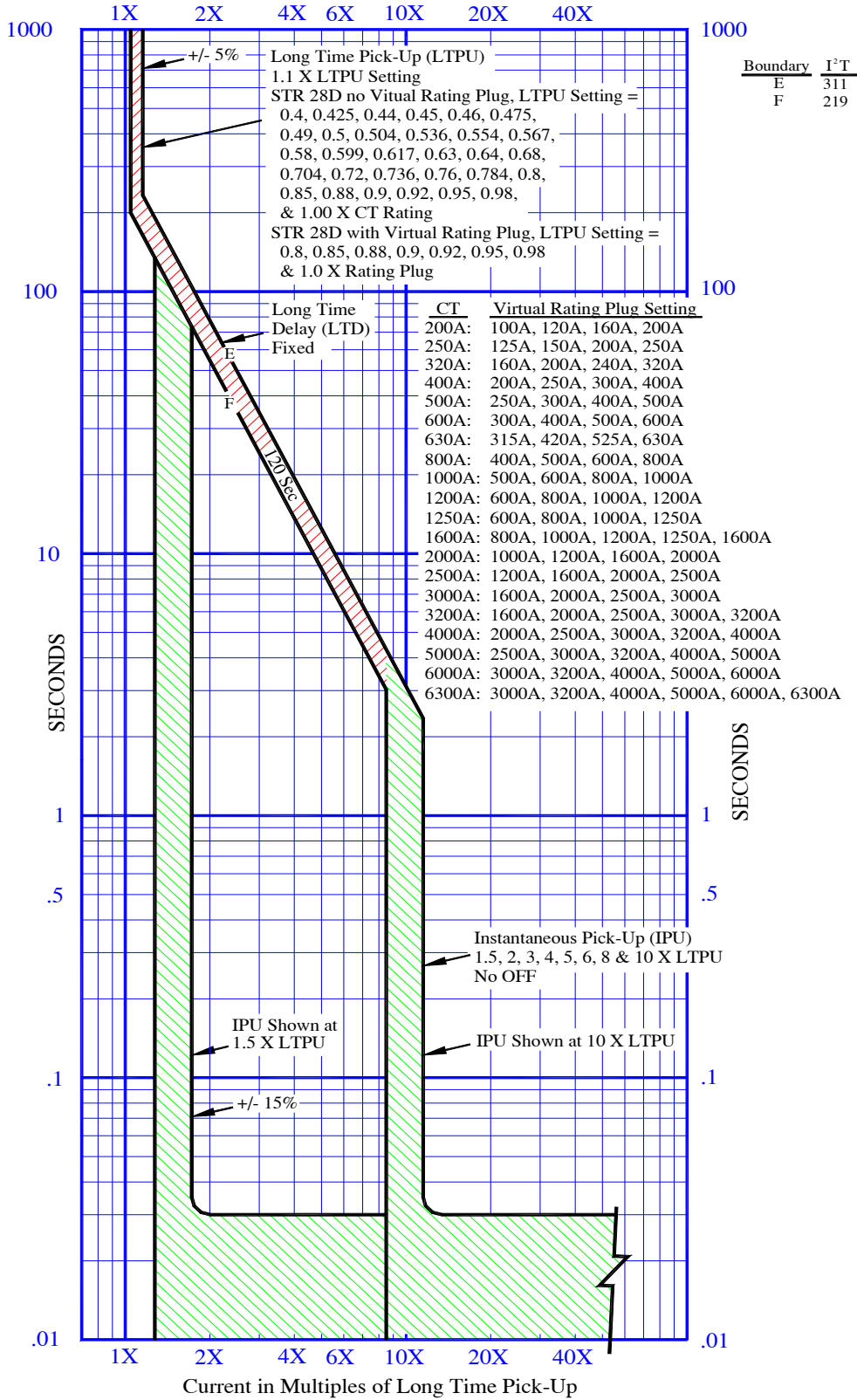

AC-PRO-MP & AC-PRO-MP-II with STR-28D setting

21.3 STR-38S Time-Current-Curve

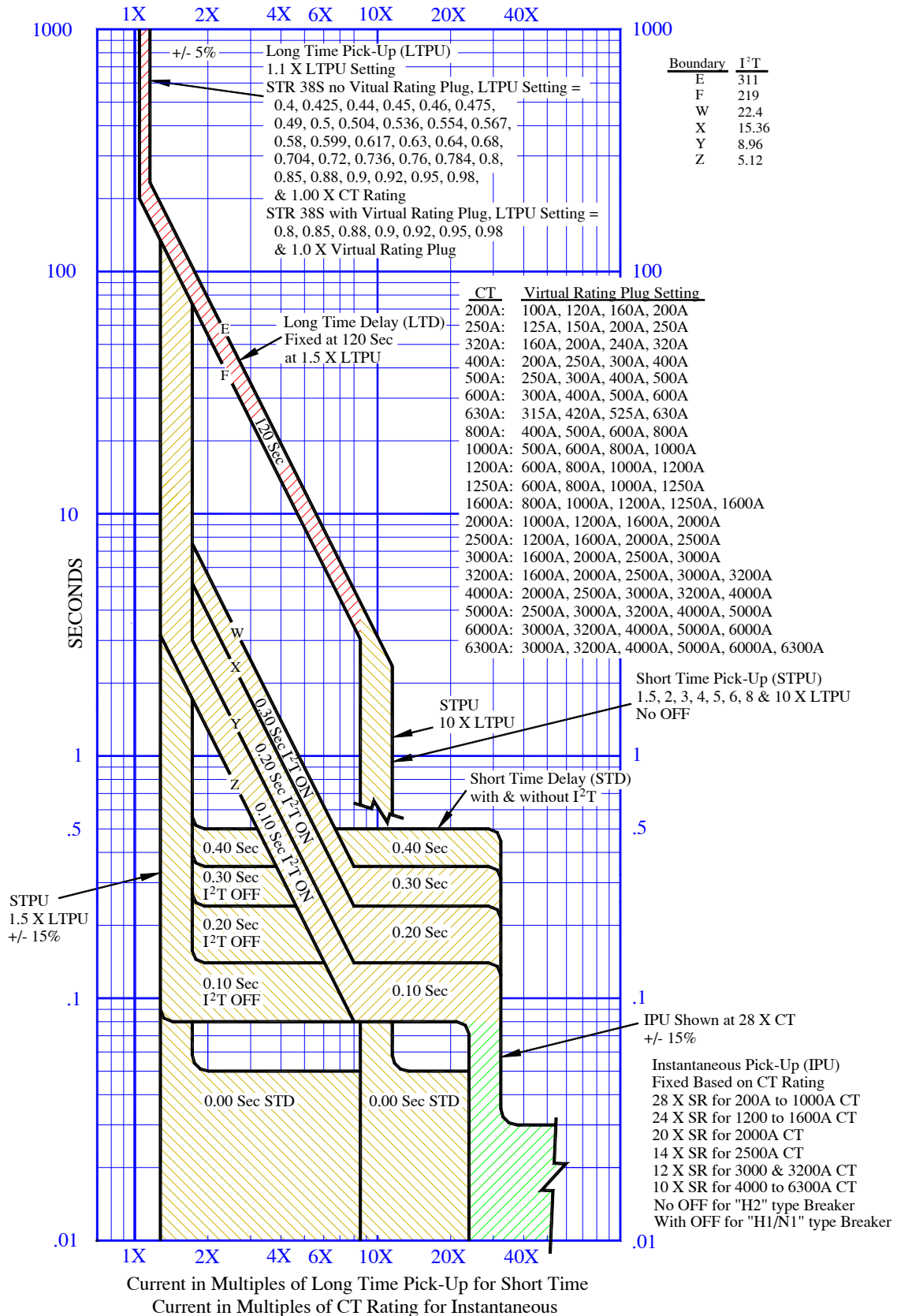

AC-PRO-MP & AC-PRO-MP-II with STR-38S setting

21.4 STR-58U Time-Current-Curve

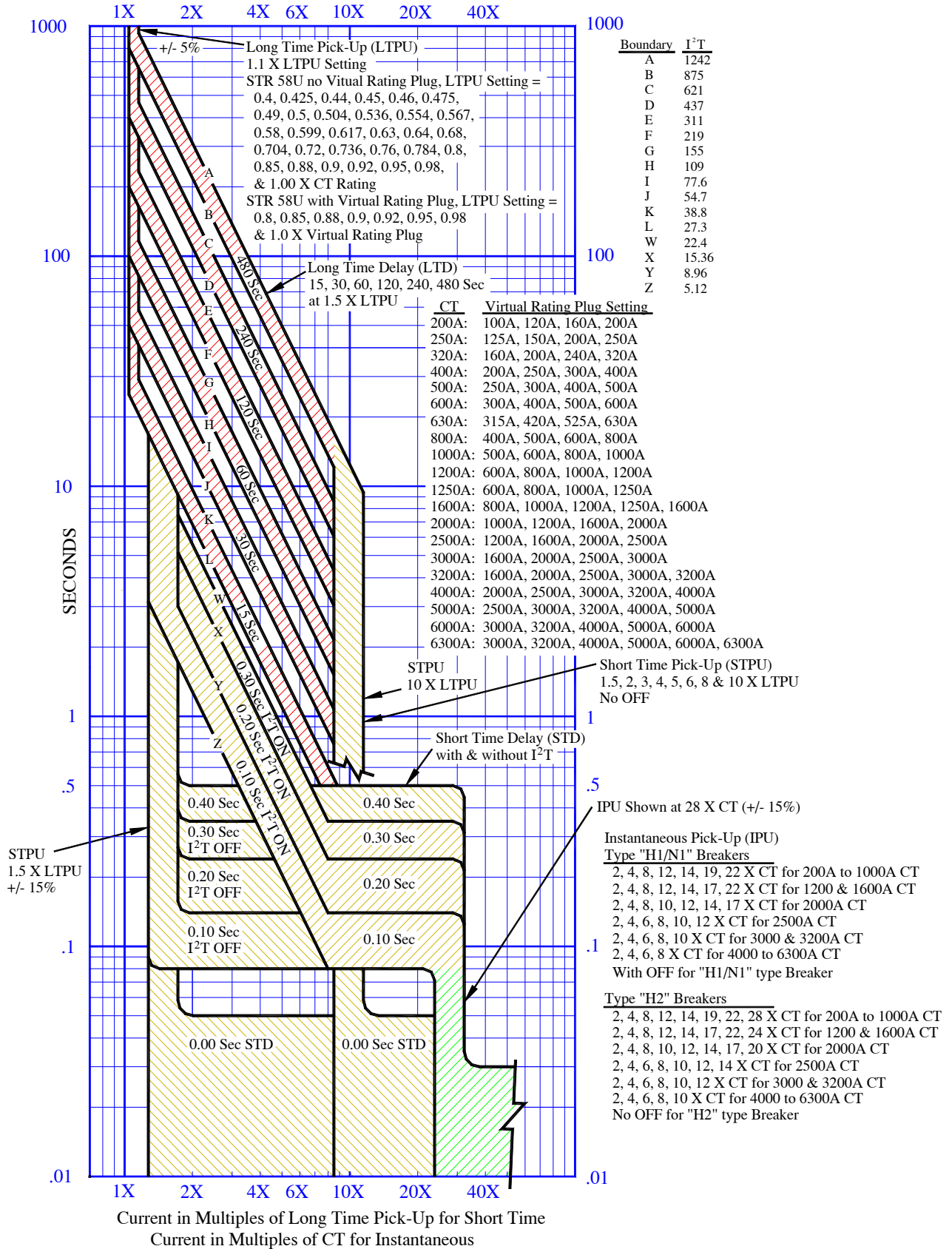

AC-PRO-MP & AC-PRO-MP-II with STR-58U setting

21.5 STR-38S & 58U Ground Fault Time-Current-Curve

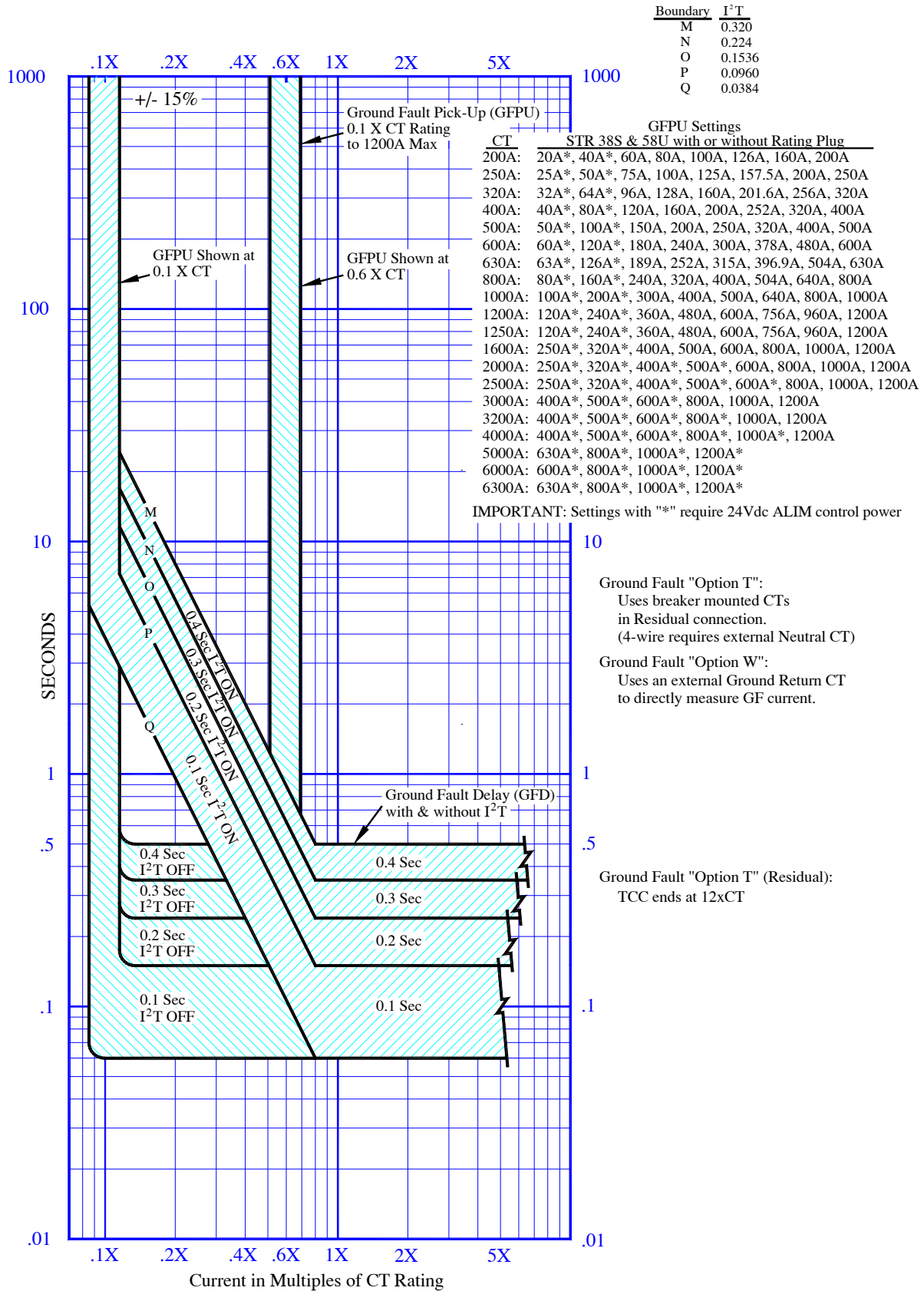

21.6 STR-58U Load Monitoring Time-Current-Curve

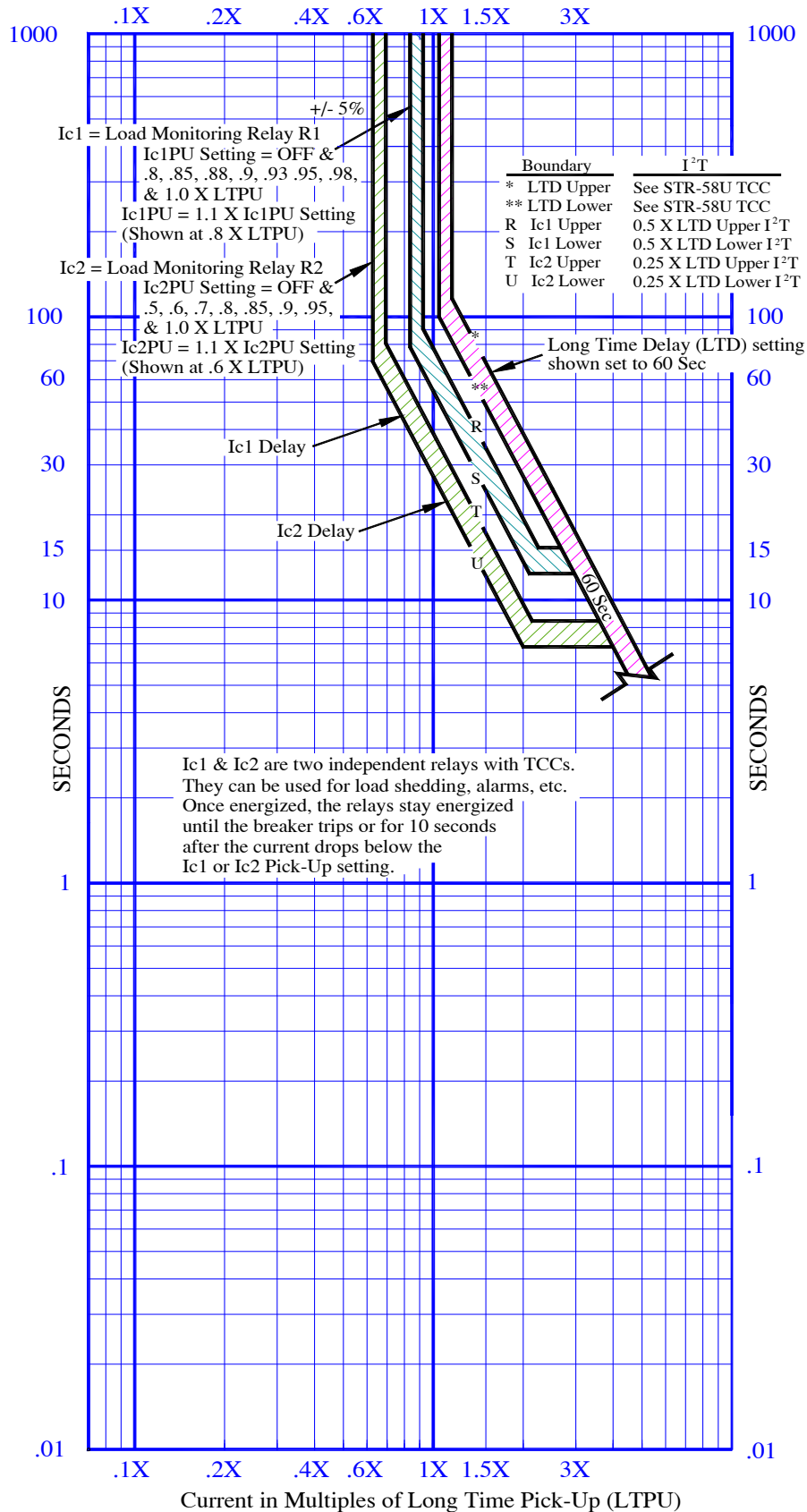

21.7 QUICK-TRIP® Instantaneous Time-Current-Curve

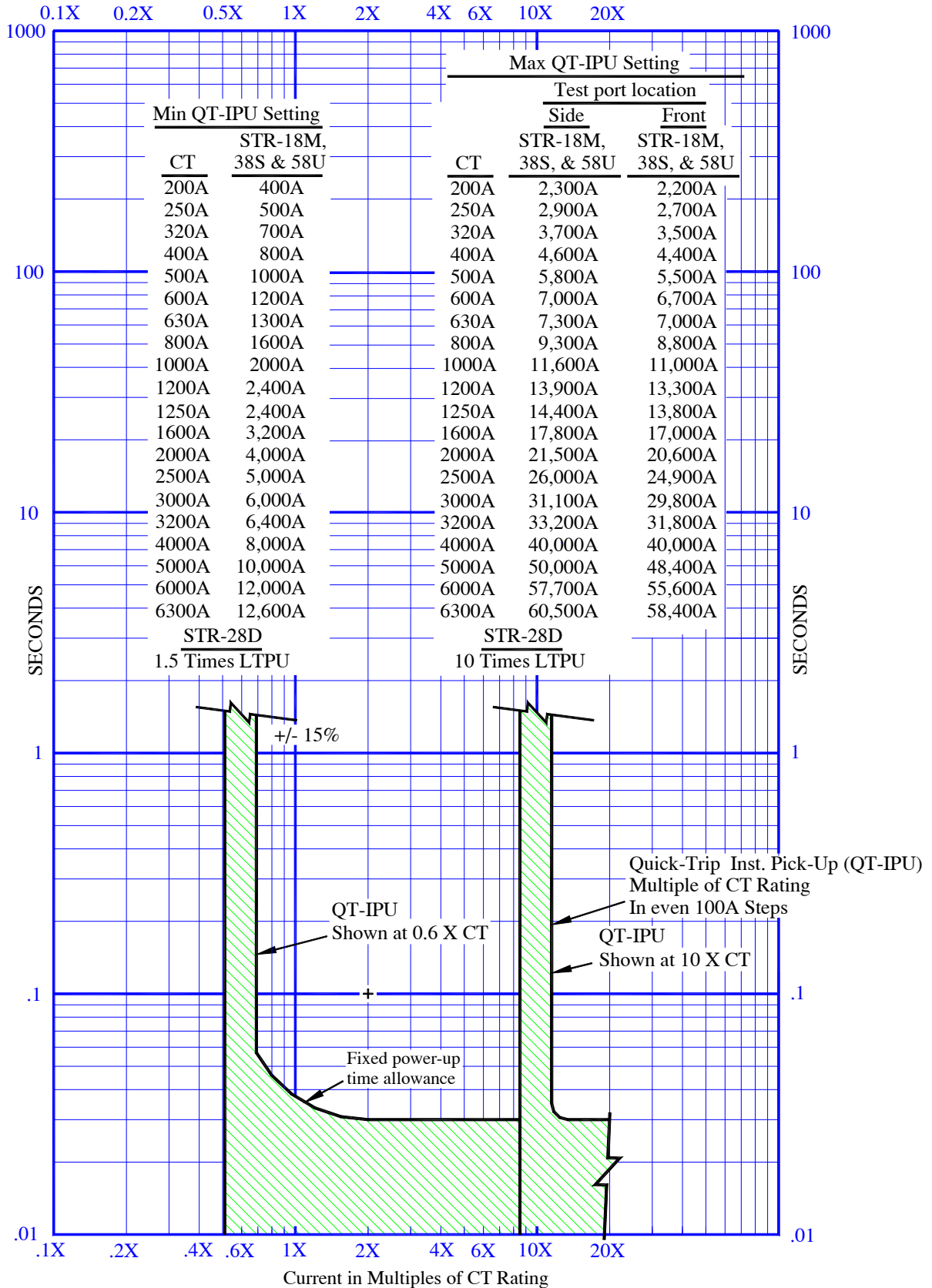

AC-PRO-MP & AC-PRO-MP-II with STR-58U setting

21.8 QUICK-TRIP® Ground Fault Time-Current-Curve

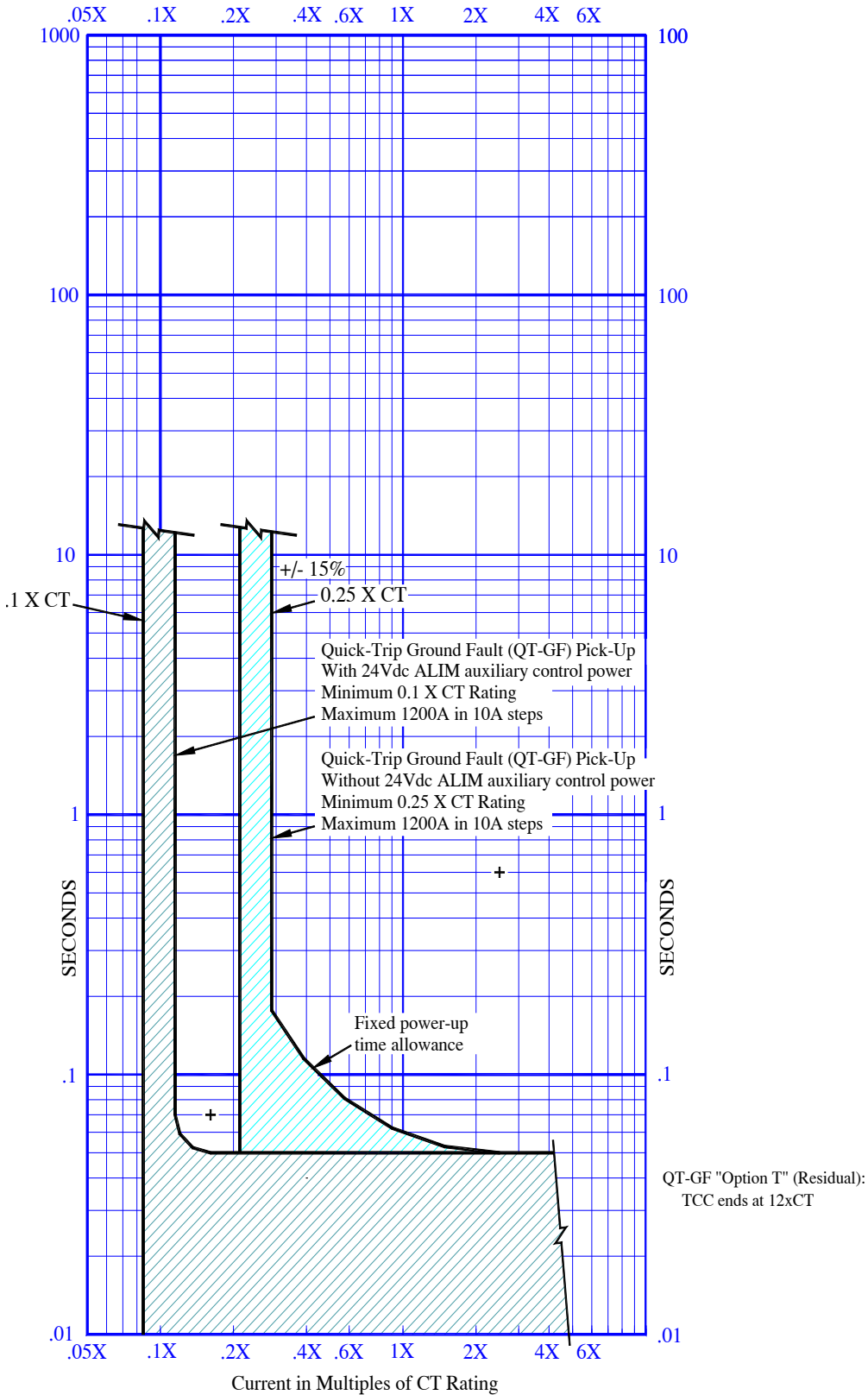

AC-PRO-MP & AC-PRO-MP-II

21.9 Neutral Overload Time-Current-Curve

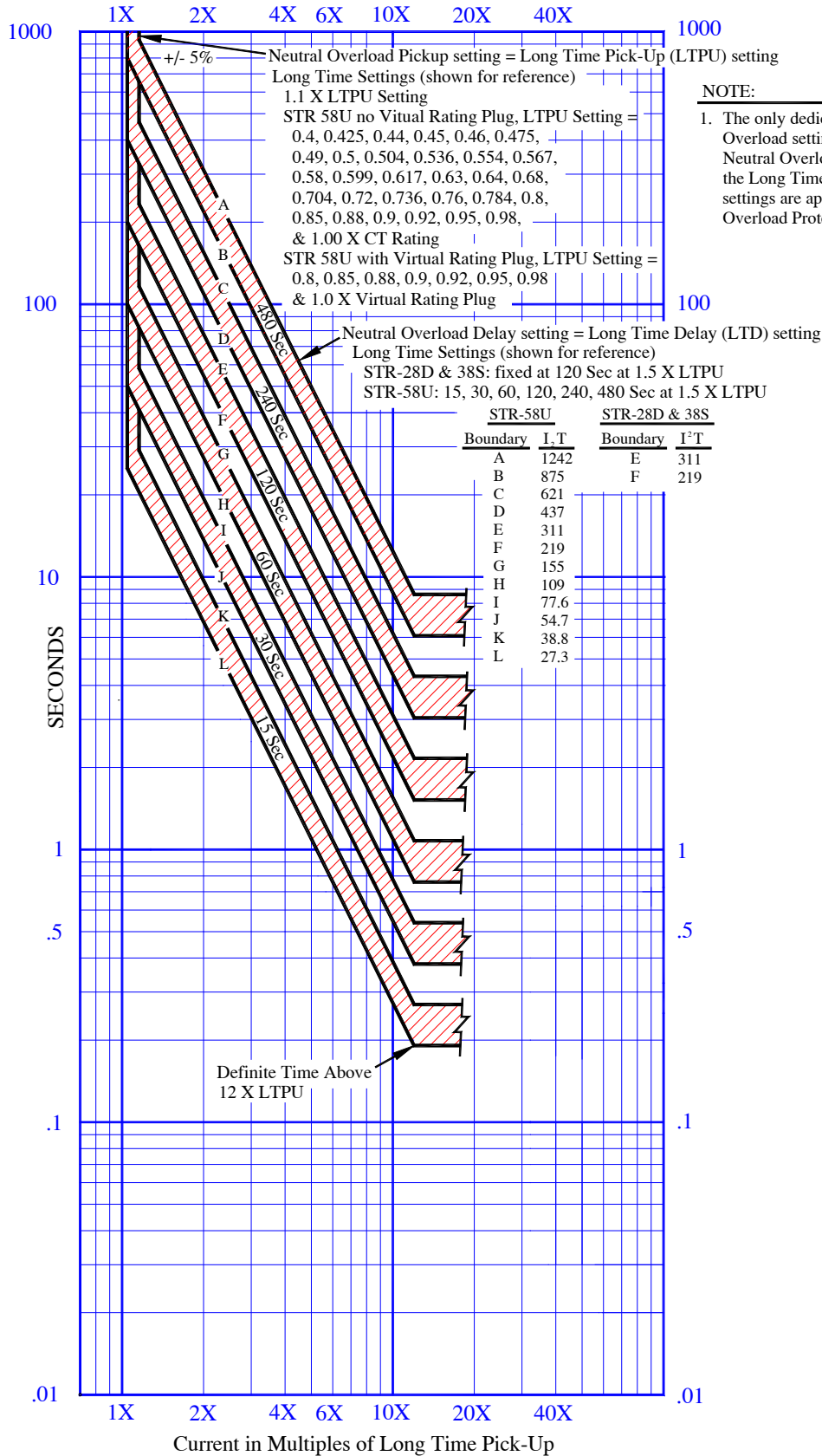

This page intentionally left blank.

This page intentionally left blank.



URC Utility Relay Company



Chagrin Falls, OH 44023
Phone: 888.289.2864
www.utilityrelay.com