

AC-PRO Retrofit Kit

Retrofit Kit Instructions for
Allis-Chalmers
LA-1600
Low Voltage Breaker

Including Instructions for
AC-PRO⁺ Communications

Utility Relay Co.
Chagrin Falls, Ohio 44023
Phone: 888-289-2864 Fax: 440-708-1000
www.utilityrelay.com

LIMITED WARRANTY

Utility Relay Co., Ltd. warrants that every AC-PRO and ZERO-Hertz trip unit and related retrofit kit components (herein collectively referred to as "product") shall be free from defects in material and workmanship, and will perform as described in Utility Relay Company's sales literature and Instruction Manuals, under normal use and service for a period of (2) two years from date of invoice. EXCEPT AS SET FORTH HEREIN, IT IS EXPRESSLY AGREED THAT THERE IS NO WARRANTY OF MERCHANTABILITY OR FITNESS FOR A PARTICULAR PURPOSE, AND THERE IS NO OTHER WARRANTY, EXPRESS, IMPLIED OR STATUTORY, BY UTILITY RELAY CO., LTD. WITH REFERENCE TO THE PRODUCT.

Should any warranty claim arise within the warranty period, contact Utility Relay Co., Ltd. at 888-289-2864 and do the following:

- 1.) Provide a complete description of the problem with the trip unit or retrofit kit component.
- 2.) Provide the Serial Number located on the back of the trip unit from the warranted retrofit kit.
- 3.) Obtain a Returned Materials Authorization number (RMA) and return shipping instructions.
- 4.) Promptly return the defective material to Utility Relay Company.

Warranty Disclaimer and Liability Limitation

As the sole and exclusive remedy, Utility Relay Co., Ltd. will repair or replace the trip unit and/or retrofit component(s) at no cost to the customer during the warranty period. The customer is liable and shall pay for shipment of defective products back to Utility Relay Co., Ltd. In no event shall Utility Relay Co., Ltd. be liable for any special, incidental or consequential damages.

Excluded from this warranty and not warranted by Utility Relay Company in any fashion, either expressed or implied are:

- 1.) Any product which has been disassembled (except to replace batteries), repaired, tampered with, altered, changed, or modified by persons other than Utility Relay Company's own authorized service personnel unless repair by others is made with the written consent of Utility Relay Company.
- 2.) Defects or damage to the Product resulting from wear, tear, misuse, negligence, improper storage, improper testing, impacts, or use with non-approved accessories.
- 3.) Products used for any other purpose other than originally intended by Utility Relay Company.

Visit www.utilityrelay.com for latest warranty information.

12/02/05

TABLE OF CONTENTS

Section	PAGE
1.0 General	1
1.1 Inspection	1
2.0 Initial Breaker Tests	2
3.0 Remove Existing Trip Unit	2
4.0 AC-PRO Installation	3
4.1 AC-PRO Standard Installation	3
4.2 AC-PRO Alternate Installation	3
5.0 Actuator Installation	4
5.1 Steel Front Breaker	4
5.2 Plastic Front Breaker	5
5.2.1 Existing Round Actuator	5
5.2.2 Existing Rectangular Actuator	6
5.3 Adjust Actuator	7
5.4 Replace Reset Mechanism	8
5.4.1 Existing Round Actuator	8
5.4.2 Existing Rectangular Actuator	8
5.4.3 Test Reset of Actuator	8
6.0 Current transformers	9
7.0 Wiring	10
7.1 Color Codes and Connections	10
7.2 Current Transformer Connections	11
7.3 Neutral Current Transformer	11
7.4 Actuator Connection	12
7.5 Ground AC-PRO	12
8.0 Final Test	12
9.0 Communications	13
9.1 Install PT Module	13
9.2 Install Fuse Block for PT Module	13
9.3 Communications Wiring	14

ILLUSTRATIONS

Figure		
1	Front View	15
2	Right Side View	16
3	Front View - Alternate Installation	17
4	Side View - Alternate Installation	18
5	Rear View, Existing Static Trip II CTs	19
6	Rear View, New CTs	20
7	Actuator Replacement, "Plastic" Front	21
8	Alternate Actuator Installation, "Plastic" Front	22
9	Front View - Actuator Bracket Installation	23
10	Actuator Replacement, "Steel" Front	24
11	Wiring Diagram	25
12	Wiring Diagram - LimiTrip CTs	26
13	Front View with Communications	27
14	PT Module Installation	28
15	Wiring Diagram with Communications	29

Allis-Chalmers
LA-1600

1.0 General

All possible contingencies, which may arise during the installation, operation or maintenance, and all details and variations of this equipment, are not necessarily covered by these instructions.

1.1 Inspection

Carefully inspect the retrofit kit on arrival. If any damage is found, file a claim with the carrier and contact Utility Relay Co. for replacement parts.

Verify that this is the correct kit for the circuit breaker being retrofitted.

Check the contents of the retrofit kit package against the kit bill of material to make sure that all the required parts are included.

Thoroughly read and understand these installation instructions as well as the AC-PRO trip unit instruction manual before proceeding with the retrofit.

2.0 Initial Breaker Tests

Before starting the retrofit, perform a visual/mechanical inspection and an electrical test of the breaker to determine its condition.

Refer to the breaker manufacturer's instruction manual and accepted test standards such as the NETA Maintenance Specifications or PEARL reconditioning standards to verify that the breaker is in acceptable mechanical and electrical operating condition.

As a minimum, perform the following:

- a) Close and trip operation of the breaker.
- b) Measure contact resistance of each pole.
- c) Measure insulation resistance from pole to pole, from pole to frame and across open contacts.
- d) Check contact compression.
- e) Check for sufficient finger cluster spring tension at the rear stabs.

Rectify any abnormalities found. Clean and lubricate the breaker as required.

3.0 Remove Existing Trip Unit

- 1) Disconnect the wiring harness from the old trip unit.
- 2) Remove the trip unit and the mounting bracket.
- 3) If new CTs are to be installed, remove the three existing CTs after removing the finger clusters.
- 4) Remove the wiring harness with the exception of the actuator wires if the actuator will be reused. Leave about 4" of wire on the CTs if they will be reused.

4.0 AC-PRO Installation

4.1 AC-PRO Standard Installation

The trip unit mounts vertically on the lower right side of the frame as shown in Figures 1 and 2.

- 1) Attach the mounting bracket BR-078 to the back of the trip unit so the short leg of the bracket is pointing towards the rear. Use two (2) 8-32 X 3/8 Phillips screws and lock washers.
- 2) Attach the mounting bracket BR-079 to the BR-078 bracket using two (2) 8-32 X 3/8 Phillips screws and lock washers.
- 3) Attach the trip unit/bracket assembly to the frame using two (2) 1/4-20 X 5/8 Button head screws, flat washers, lock washers and hex nuts in the existing holes.

If necessary use the trip unit/bracket assembly as a guide, mark the location of two (2) mounting holes. Drill two (2) 9/32 holes in frame where marked.

4.2 AC-PRO Alternate Installation

The trip unit mounts on the horizontal frame as shown in Figures 3 and 4.

- 1) Attach the bracket BR-074 to the bracket BR-075 using (2) 8-32 X 3/8 Phillips screws and lock washers.
- 2) Attach bracket BR-074/BR-075 assembly and BR-027 shield to the back of the AC-PRO using two (2) 8-32 X 3/8 Phillips screws and lock washers.

The BR-027 shield should be behind the BR-075 bracket as shown in Figure 4.

- 3) Temporarily set the trip unit/bracket assembly on the breaker horizontal frame in a suitable position. The bracket should be behind the racking bar. See Figure 3.
- 4) Mark and drill two (2) 11/64 mounting holes.
- 5) Attach the trip unit/bracket assembly to the breaker horizontal frame using two (2) 8-32 X 3/4 RH screws, lock washers and hex nuts.
- 6) Ground the trip unit as described in Section 7.5.

5.0 Actuator Installation

If desired, the existing actuator may be re-used if in usable condition.

If the existing actuator is re-used, skip this section.

5.1 Steel (Gold) Front breaker

See Figure 10 for the following:

- 1) Remove the existing actuator, shield and bracket from the breaker.
- 2) Attach the shield to the BR-113-1 bracket using two (2) 10-32 X 1/2 Phillips screws, lock washers and hex nuts.
- 3) Remove the reset knob from the actuator and replace the actuator rod with the 4 1/2" rod provided. Transfer the vinyl tip, two jam nuts and the lock washer to the new rod.

Use care since the actuator plunger is spring loaded.

- 4) Attach the actuator to bracket BR-113-1 with three (3) 10-32 X 3/8 R.H. screws and lock washers.
- 5) Attach the actuator/bracket assembly to the breaker using the existing hardware. Do not reinstall the reset mechanism at this time.
- 6) With the breaker closed, the springs charged and the actuator reset, adjust the position of the actuator rod by screwing it in or out until the end of the rod is about 1/64" from the trip paddle.
- 7) As the initial adjustment, locate the two (2) 1/4-20 jam nuts to limit the actuator rod travel to about 1/2".

5.2 Plastic (Blue) Front breaker

5.2.1 Existing Round Actuator

See figure 7 for the following:

- 1) Remove the reset mechanism and the existing actuator from its bracket.
- 2) Remove the reset knob and jam nut from the A-100 actuator as well as the plastic tip.
- 3) Attach the actuator to the existing bracket using three (3) 10-32 X 3/4 studs, lock washers and hex nuts. Do not replace the reset bracket at this time.

Do not allow the studs to bottom out in the actuator.

- 4) Verify that there is sufficient clearance between the actuator body and the mechanism linkage by closing and opening the breaker. If the actuator body interferes with the linkage, use two (2) 1/4 flat washers as shims between the bracket and the existing spacers.
- 5) Screw a HW-9903-3 collar clamp on the end of the A-100 actuator rod until it is about 1/64" below the trip paddle. Tighten the clamp screw.
- 6) Make the initial settings as shown on Figure 7.

5.2.2 Existing Rectangular Actuator

See figure 8 & 9 for the following:

- 1) Remove the reset mechanism and the existing actuator from the breaker.
- 2) On the new A-100 actuator, replace the exiting actuator rod with the new 6" actuator rod provided. The end of the actuator rod should be 2" from the bottom of the actuator.

Screw the two (2) 1/4-20 stop nuts and lock washer onto the actuator rod and lock together so that the actuator stroke is 1/2 in. See Figure 8.

Use caution since the plunger is spring loaded.

- 3) Attach the actuator to BR-134 Actuator bracket using three (3) 10-32 X 3/8 Phillips Head screws and lock washers.
- 4) Attach BR-1A023 Bracket to the frame using the existing hole. Mark and drill the second hole to attach the bracket. See Figure 9.
- 5) Attach actuator assembly to BR-1A023 using (2) 1/4-20 X 3/4 round head screws, lock washers and hex nuts. Do not replace the reset bar at this time.
- 6) Close the breaker.
- 7) Screw a HW-9903-3 Clamp Collar on the end of the A-100 actuator rod until it is about 1/64" below the trip paddle. Tighten the clamp screw.

5.3 Adjust Actuator

- 1) Trip the breaker. Trip the actuator by striking the end of the actuator rod. Lock the actuator rod in position by tightening the 10-32 set screw with an Allen wrench.
- 2) Adjust the stop nuts as necessary to limit the actuator rod travel within the limits of the trip bar.
- 3) With the actuator reset, close the breaker. If the breaker will not close because the actuator rod is interfering with the trip paddle, re-adjust the position of the actuator rod.
- 4) Operate the actuator by lightly striking the end of the actuator rod or use a fresh 9 volt battery (red is "+"). The breaker should trip. Verify that the trip paddle is not against its limit of travel.
- 5) Attempt to close the breaker without resetting the actuator. The breaker should trip free, if not, increase the actuator rod travel.

<p>IMPORTANT: WITH THE ACTUATOR IN THE TRIP POSITION (NOT RESET), THE BREAKER MUST BE TRIP-FREE.</p>

5.4 Replace Reset Mechanism

5.4.1 Breakers that had an Existing Round Actuator

- 1) Replace the existing reset mechanism using a silicone rubber washer and enough hard fiber shims to assure a positive reset of the actuator.

5.4.2 Breakers that had an Existing Rectangular Actuator

- 1) Place the spring and flat washer on the actuator rod.
- 2) Close the breaker.
- 3) Carefully replace the existing reset bar by sliding it in from the front of the breaker. Attach the 1-1/4" O.D. washer to BR-1A023 using a 10-32 X 3/8 screw and lock washer. This is to ensure the reset bar stays in place.

5.4.3 Test Reset of Actuator

- 1) Trip the breaker several times with the A-100 actuator until completely satisfied with the trip and reset operation. It may be necessary to change some of the settings and add or remove a shim. Use a fresh 9 volt battery to trip the actuator (red is "+" and black is "-").

<p>IMPORTANT: THE <u>SET SCREW</u> IN THE PLUNGER MUST BE TIGHTENED TO ENSURE THAT THE ACTUATOR ROD REMAINS IN PROPER ADJUSTMENT.</p>
--

6.0 Current Transformers

If installing new CT's, see Figure 6.

If the existing CTs will be reused, skip this section.

- 1) Align the "A" on the BR-693 CT insert to the indicator mark on the mounting tab on the CT. The BR-693 CT insert should be behind the mounting tabs on the CT.
- 2) Attach the BR-693 CT insert to the CT using four (4) 10-24 X 1/2 self-tapping screws. Tighten the self-tapping screws until they seat but do not over-tighten to avoid damaging the BR-693 CT insert.

IMPORTANT: Just tighten the self-tapping screws until they seat. Do not tighten any further to avoid damaging the BR-693.
--

- 3) Slide the Phase "A" and "C" CTs on the upper stabs and the "B" Phase CT and the lower stab.

IMPORTANT: THE CTs MUST BE INSTALLED WITH THE TERMINALS ORIENTED AS SHOWN IN FIGURE 6.

- 4) Replace the finger clusters.

7.0 Wiring

Use the wiring harness provided to make the connections to the CTs and the actuator. See Figure 11 for the wiring diagram.

The wiring harness plugs into the right side of the AC-PRO. Be sure to tighten the two plug retaining screws after the wiring is complete.

Shorten the wires and tubing as required and use the cable ties and holders provided to make a clean installation. Make sure the wires will not be pinched, cut or chaffed by any moving parts or sharp edges

7.1 Color Codes and Connections

The wiring harness connector color code and connections for new CT's are as follows from left to right:

<u>Terminal #</u>	<u>Wire Color</u>	<u>Use</u>
1	Red (R)	Actuator "+"
2	Black (B)	Actuator "-"
3	Blue (L)	Phase "A" "Dot"
4	White (W)	Phase "A" Tap
5	Yellow (Y)	<u>Phase "B" Tap</u>
6	White (W)	<u>Phase "B" "Dot"</u>
7	Brown (N)	<u>Phase "C" "Dot"</u>
8	White (W)	Phase "C" Tap
9	Green (G)	Neutral "Dot" (4W & GF only)
10	White (W)	Neutral Tap (4W & GF only)

7.2 Current Transformer Connections

Each set of CT wires in the wiring harness is housed inside an individual PVC tube for added physical protection and to simplify the wiring process.

New Current Transformers:

If new CTs are installed, connect to the #6-32 terminals using the ring tongue terminals provided.

Since the "B" phase CT is mounted on the load side of the breaker, it is necessary to reverse the wires on that CT. If the wires are not reversed, a nuisance ground fault trip is likely to occur.

IMPORTANT: Reverse the wires on the "B" Phase CT.

The White wire connects to the common, "Dot" lug.

Existing Current Transformers:

If the existing CTs are being re-used, connect to the CT wires using the knife connectors and Teflon tubing provided. Use the color codes as shown in Figure 5 for Static Trip II CTs. For LimiTrip CTs see Figure 12.

If the CTs are staggered, make sure that the "B" phase CT is flipped on the stab to maintain proper polarity.

Verify that the CT secondary is 1 Amp to match with the 1 Amp AC-PRO provided.

7.3 Neutral Current Transformer

A neutral CT is only required on a 4-wire system with the ground fault function on.

On a 3-wire system, a neutral CT is not required even if the ground fault function is on.

The neutral CT and neutral wiring assembly are provided with the neutral CT kit.

7.4 Actuator Connection

New A-100 Actuator:

Route the red and black wires from the actuator to the "ACTUATOR" terminal block on the trip unit. Trim the wires to an appropriate length. Use the protective sleeving on the wires.

Connect the red actuator wire to the "+" terminal on the wiring harness trip unit connector. Similarly, connect the black actuator wire to other terminal on the trip unit.

Existing Actuator:

The wiring harness has the actuator wiring assembly that consists of a red wire and a black wire inside a PVC protective tube.

Route the actuator wiring assembly to the actuator and shorten the wires and tubing as required.

Connect to the existing actuator wires using the knife connectors and Teflon tubing provided. Red is "+" on the existing actuator as well as in the actuator wiring assembly.

7.5 Ground AC-PRO

For the alternate installation, ground the trip unit as follows:
(See Figure 4)

- 1) Attach one end of the #14 SIS wire to the trip unit using a #10 ring terminal.
- 2) Attach the other end of the #14 SIS wire to the breaker frame using a #10 ring terminal. Make sure the wire will not be pinched, cut or chaffed by any moving parts or sharp edges.

8.0 Final Test

Perform a final electrical test of the breaker as in Section 1.

A primary injection test is recommended as the final test of the AC-PRO retrofit. See Section 11 "TESTING" in the AC-PRO instruction manual for complete details.

9.0 Communications

The following instructions are for the communications option using the AC-PRO⁺:

9.1 Install PT Module

The PT Module mounts on the left side of the horizontal frame as shown in Figures 13 and 14.

- 1) Attach the BR-040 bracket to the PT Module using two (2) 8-32 X 3/8 Phillips screws and lock washers. See Figure 14.
- 2) Attach the BR-039 shield and BR-041 bracket to the BR-040 bracket using two (2) 10-32 X 1/2 Phillips screws and lock washers. See Figure 14.
- 3) Using the PT Module/bracket assembly as a guide, mark the location of the two (2) mounting holes. Drill two (2) 13/64 holes where marked.
- 4) Attach the PT Module/bracket assembly to the breaker using two (2) 10-32 X 1/2 Phillips screws and lock washers.

9.2 Install Fuse Block for PT Module

- 1) Attach the 3-pole fuse block to the breaker as close to the line side stabs as possible.
- 2) Drill and tap two (2) 8-32 holes using the fuse block as a guide.
- 3) Attach the fuse block to the back of the breaker using two (2) 8-32 X 3/8 Phillips screws and lock washers.

9.3 Communications Wiring

See figure 15 for the following:

1) Voltage Input

Determine the line side of the breaker and drill and tap a 10-32 hole in each of the three line side poles.

Use #14 SIS wire from the bus taps to the 3-pole fuse block. *It is very important to maintain the proper phasing.*

Use #18 MTW wire from the 3-pole fuse block to the PT Module. Use fiberglass sleeving to protect the wires.

2) Ground Input

Connect a #18 MTW wire from the "Ground" terminal of the PT Module to the breaker frame.

3) PT Module Harness

Plug the PT Module cable into the left side of the AC-PRO⁺ trip unit and the PT Module.

Use cable ties and holders to make a clean installation.

4) Breaker Position Indication

As an option, connect an unused "a" contact in the breaker auxiliary contacts to the two position input terminals on the PT Module.

This will provide the breaker open or closed information to the communications system.

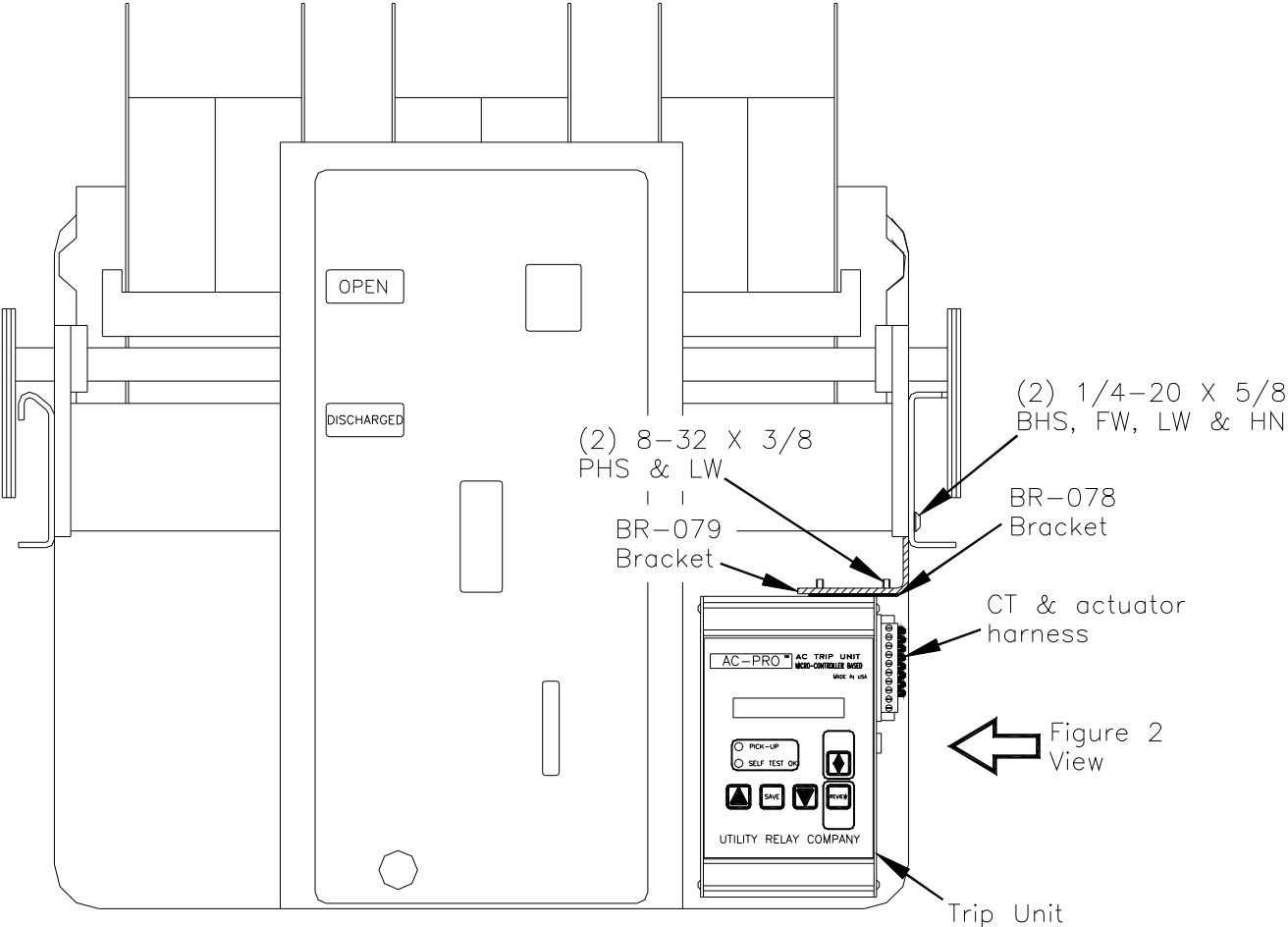

FIGURE 1
Allis-Chalmers LA-1600
Front View
Page 15

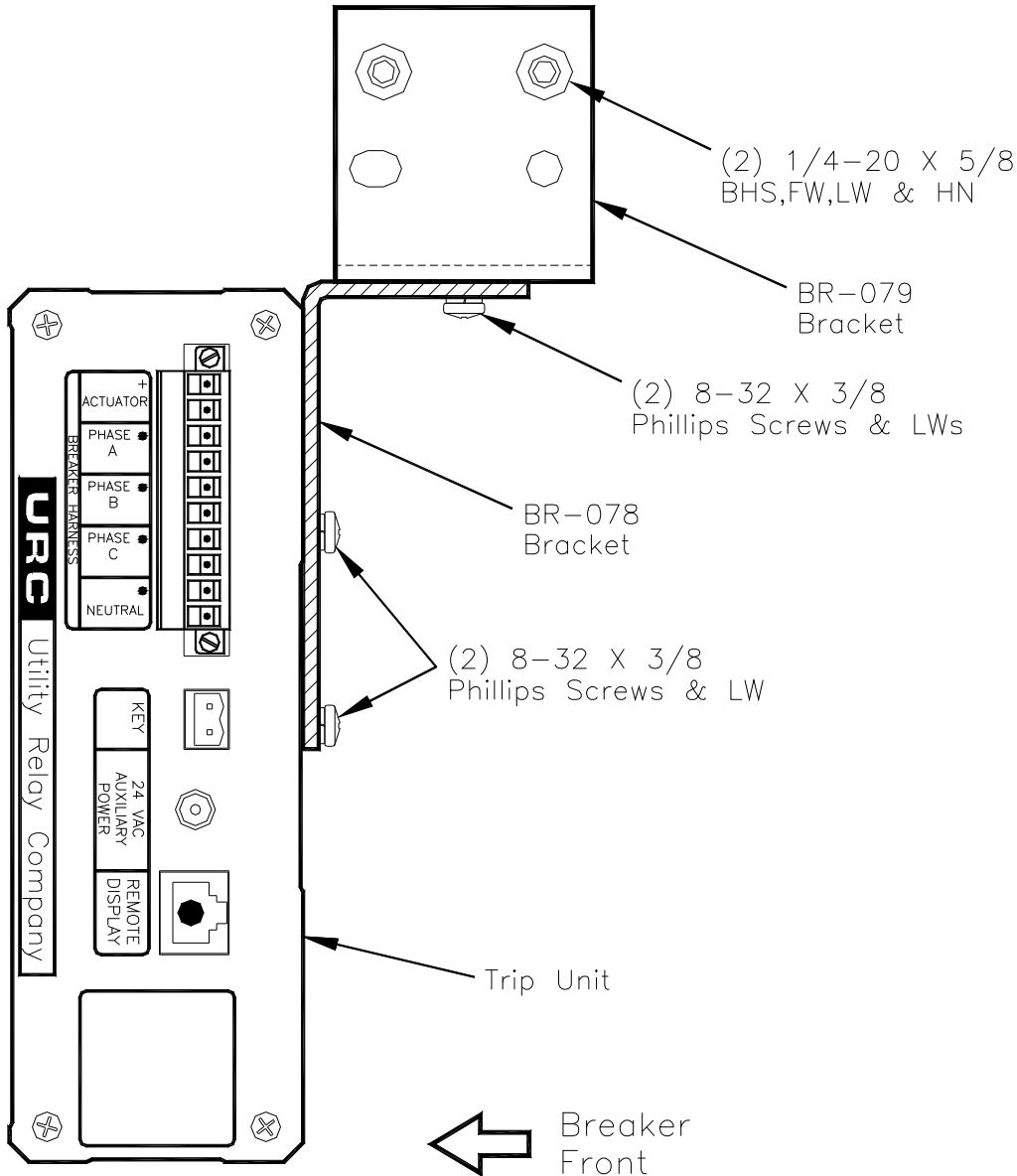

FIGURE 2
Right Side View
Trip Unit Installation

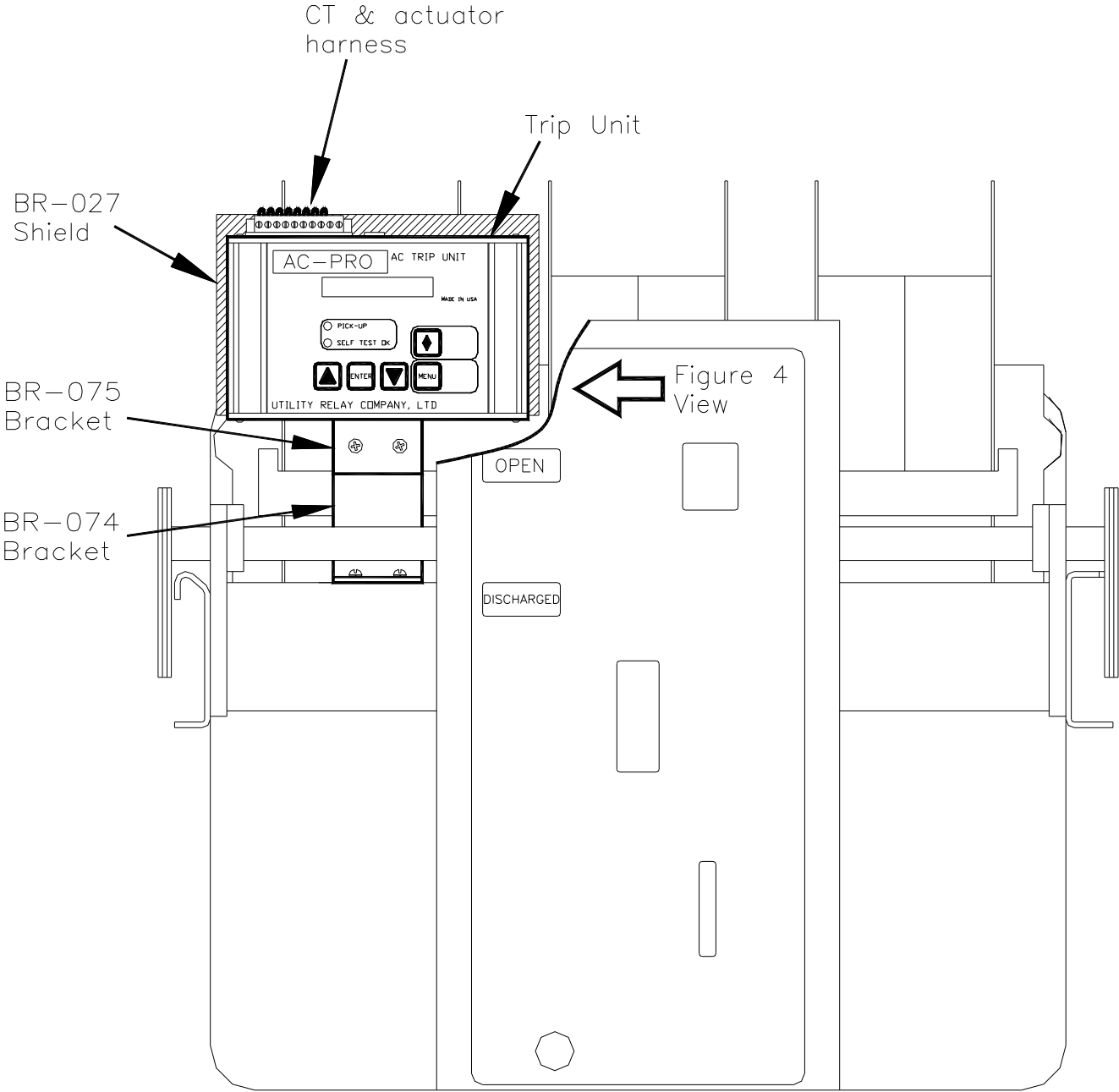

FIGURE 3
Front View
Alternate Trip Unit Installation

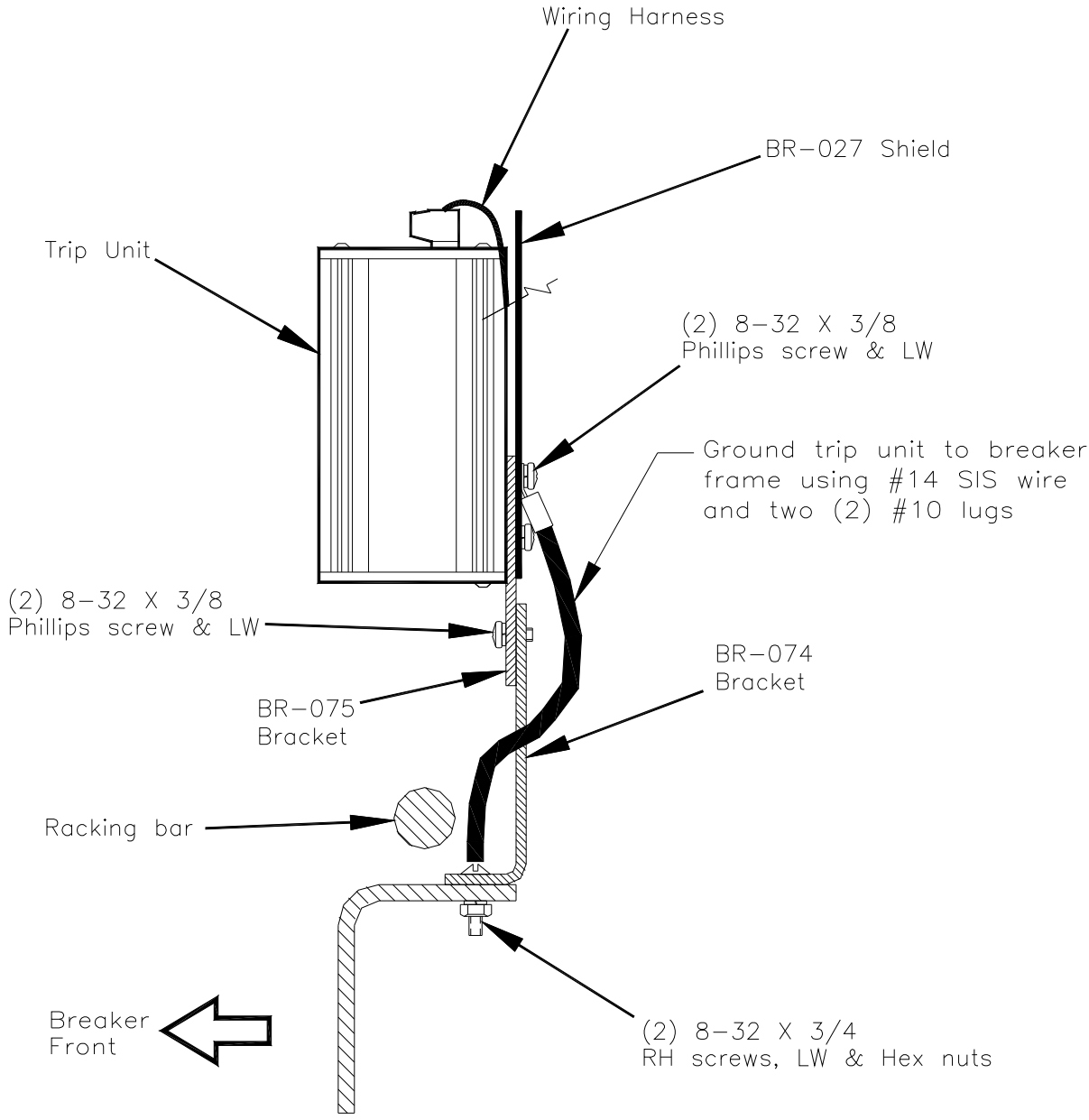
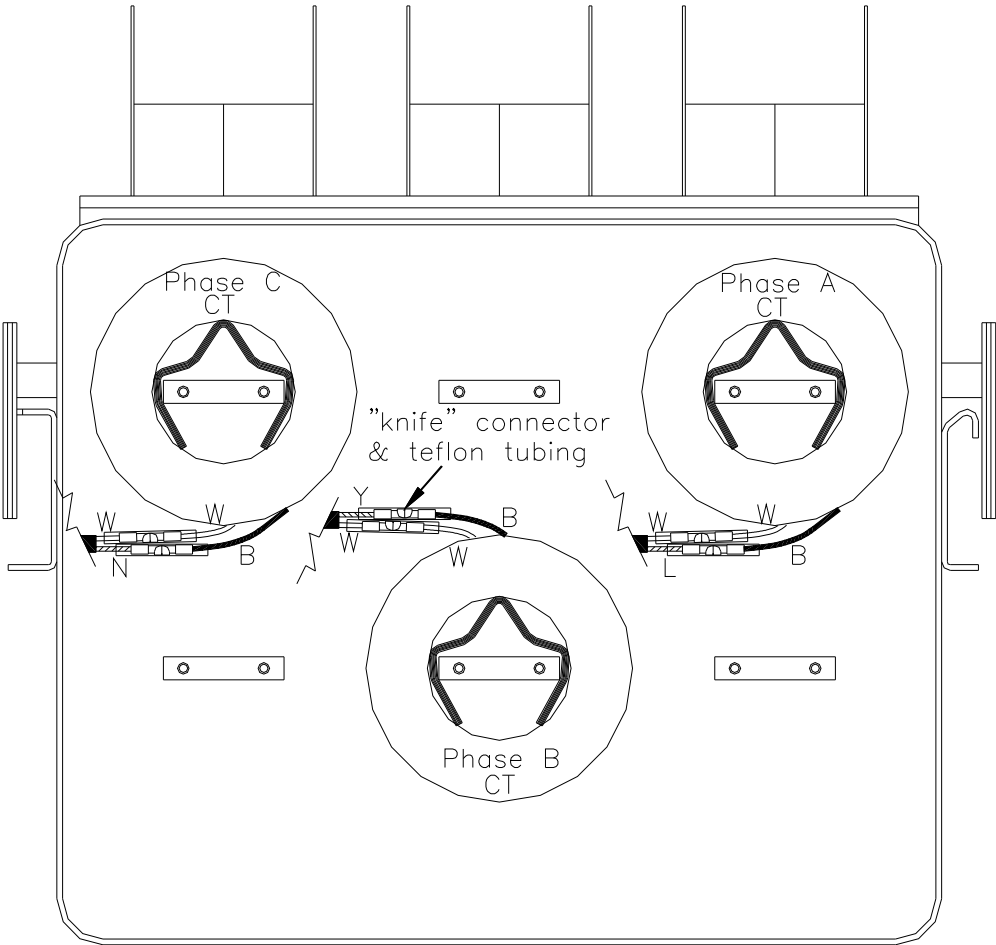

Figure 4
Side View
Alternate Trip Unit Installation
Page 18



Use "knife" connectors to connect harness wires to the existing CT wires.

Color Code
B = Black
W = White
Y = Yellow
L = Blue
N = Brown

NOTE:
Verify that the "B" phase CT is flipped on the stab to maintain proper polarity.

Rear view
(shown less finger clusters)

FIGURE 5
Rear View, Re-Using Existing Static Trip II CTs
(shown less finger clusters)

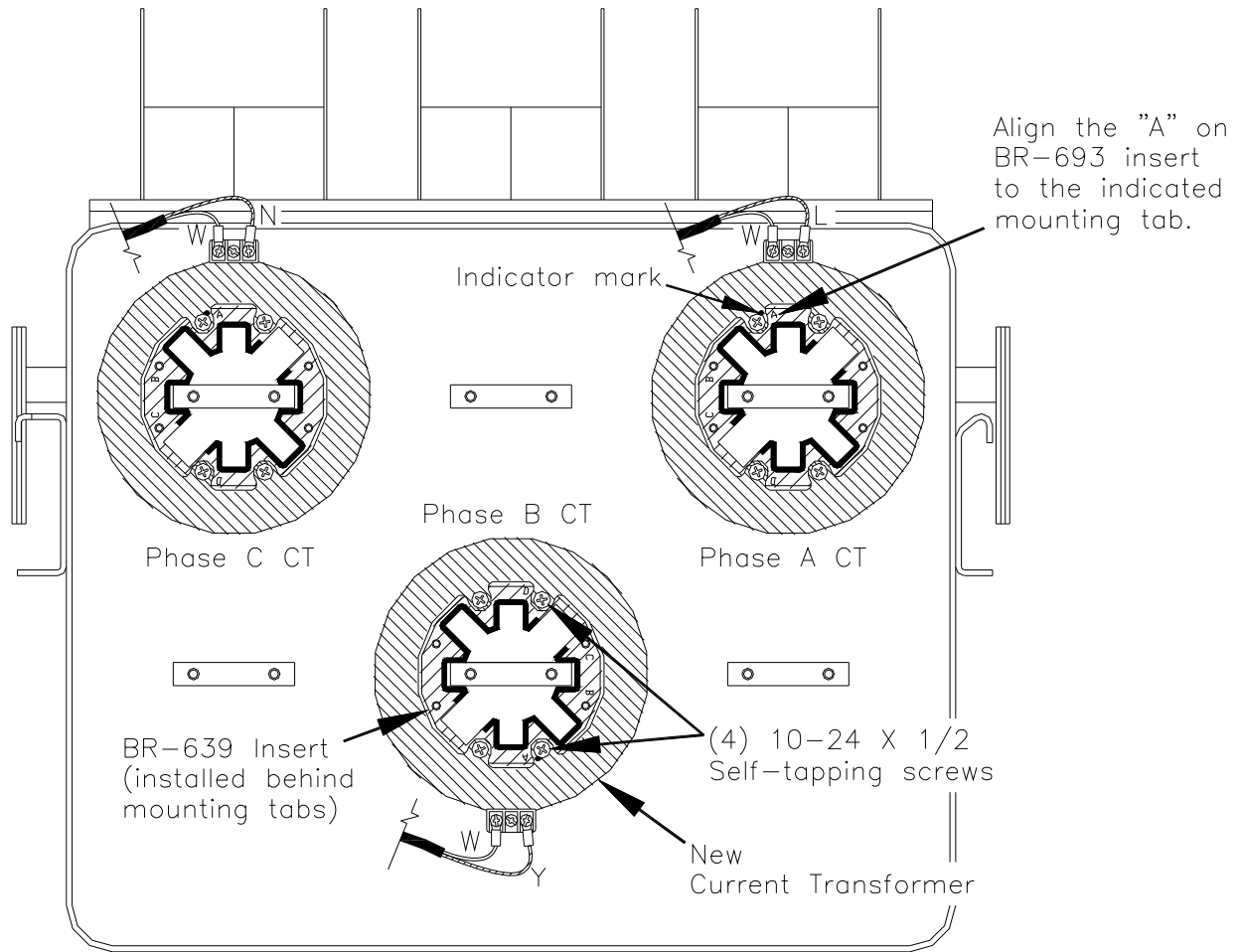

NOTE:

"B" phase CT wiring is reversed from "A" & "C" phase wiring to maintain proper polarity for ground fault.

CTs MUST be installed with terminals away from return bus as shown.

Color Code

- B = Black
- W = White
- Y = Yellow
- L = Blue
- N = Brown

Rear view
(shown less finger clusters)

FIGURE 6
Rear View, New CTs
(shown less finger clusters)

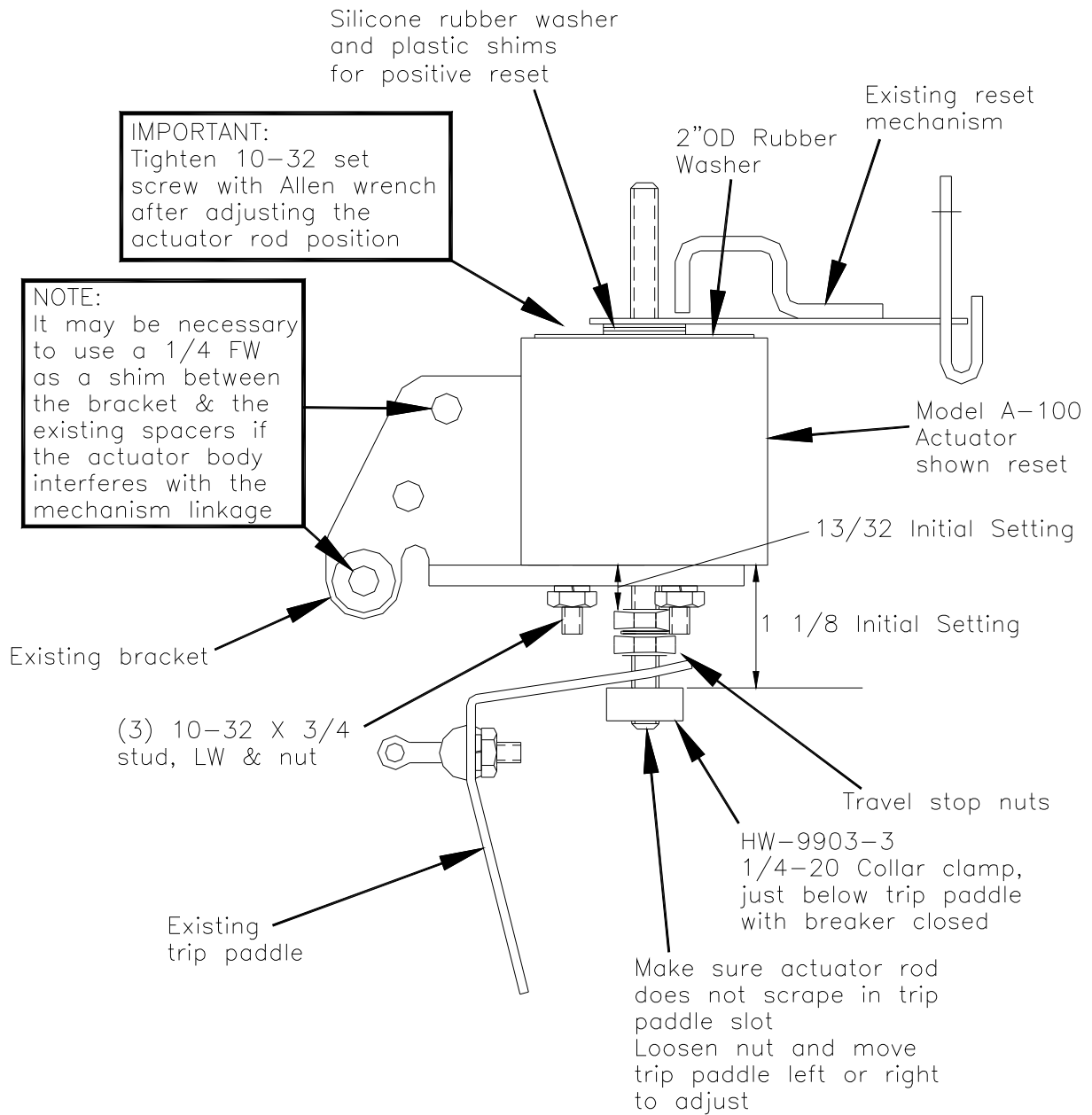

Replacement actuator
LA-1600, "Plastic" Front

FIGURE 7
Actuator Installation
"Plastic" Front

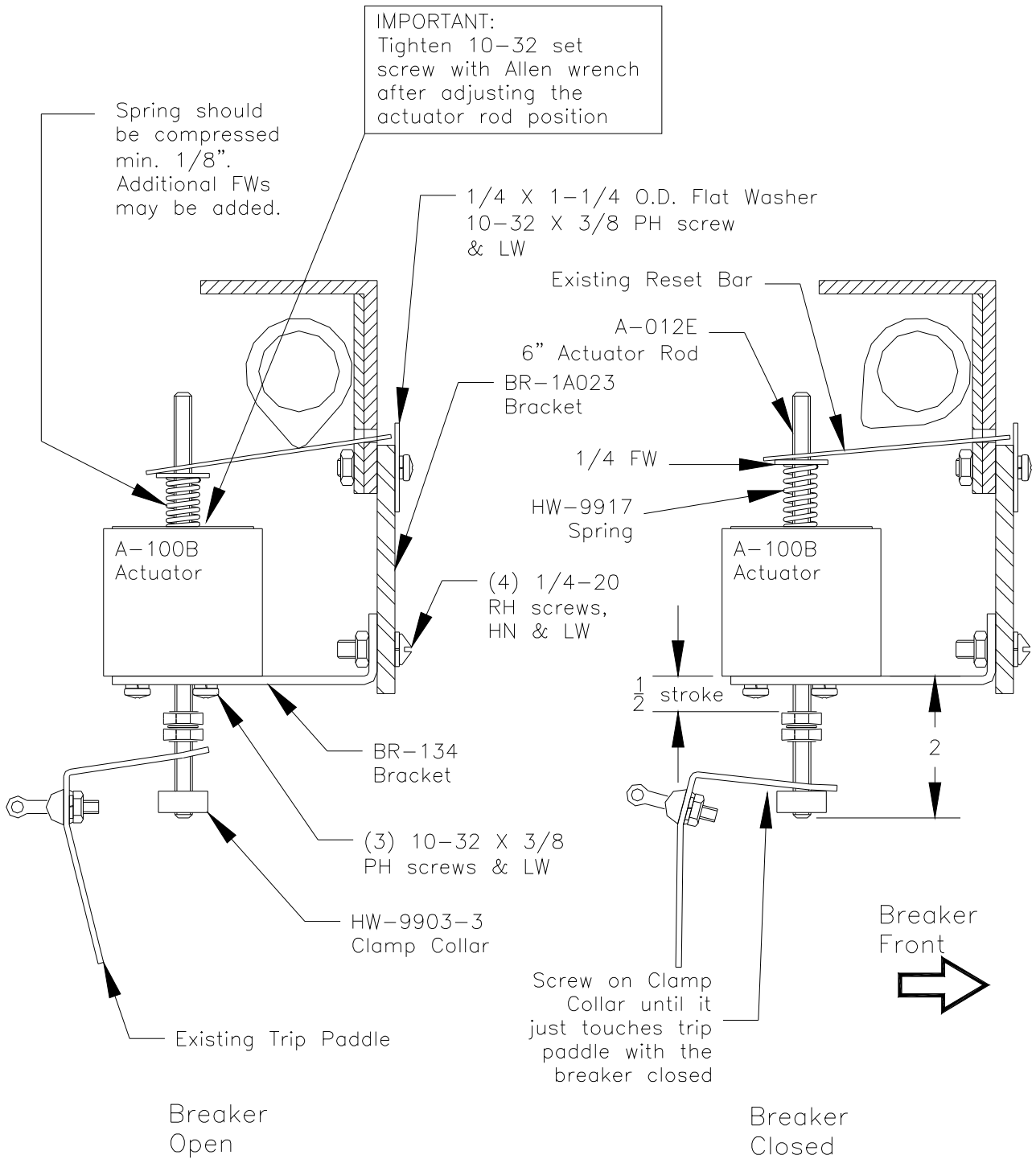

FIGURE 8
Alternate Actuator Installation
"Plastic" Front

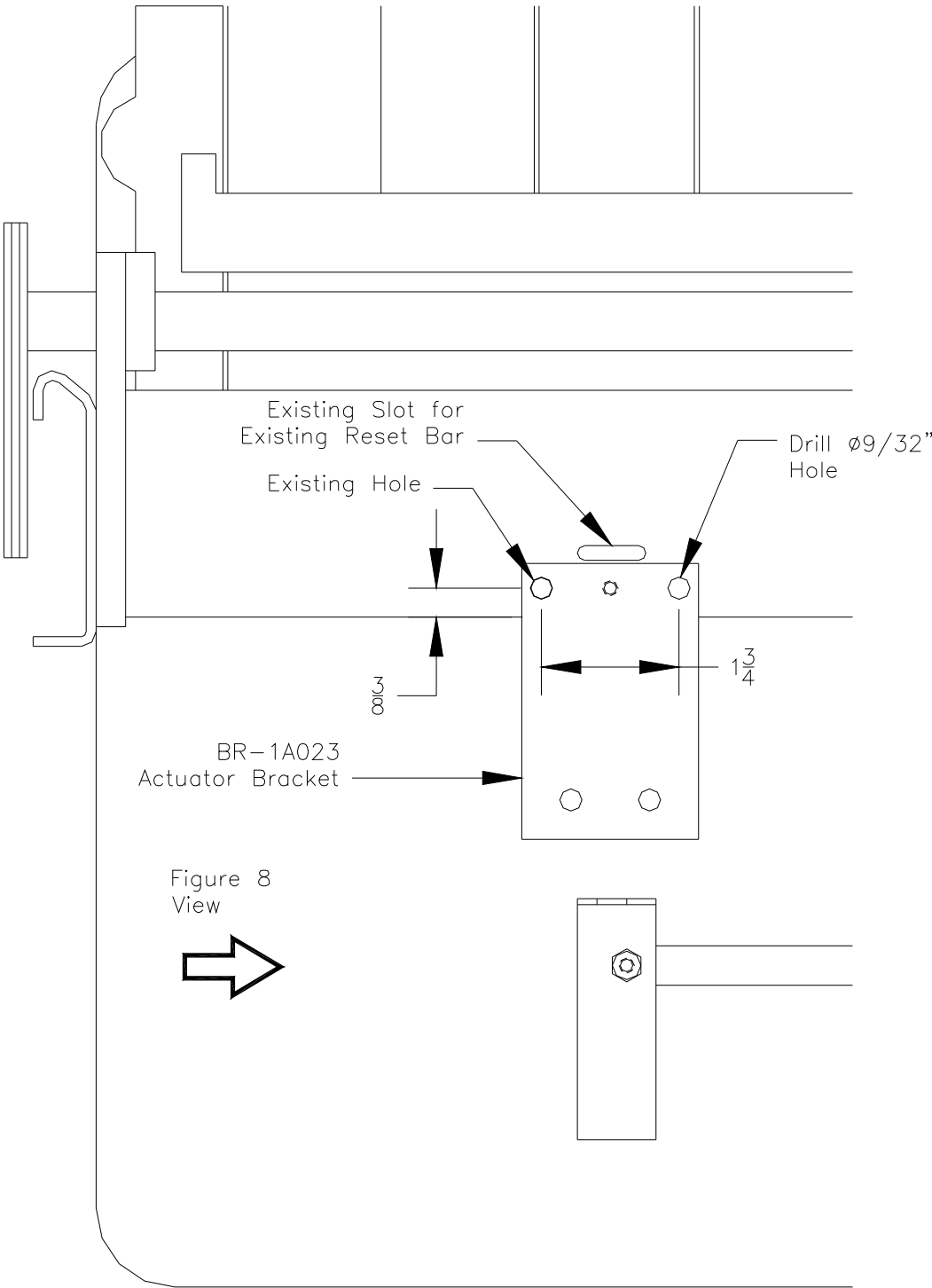
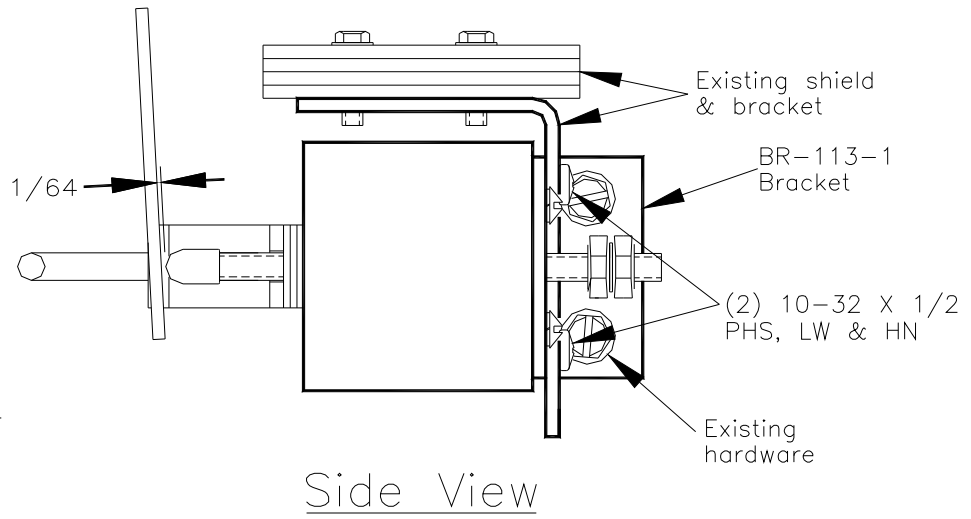
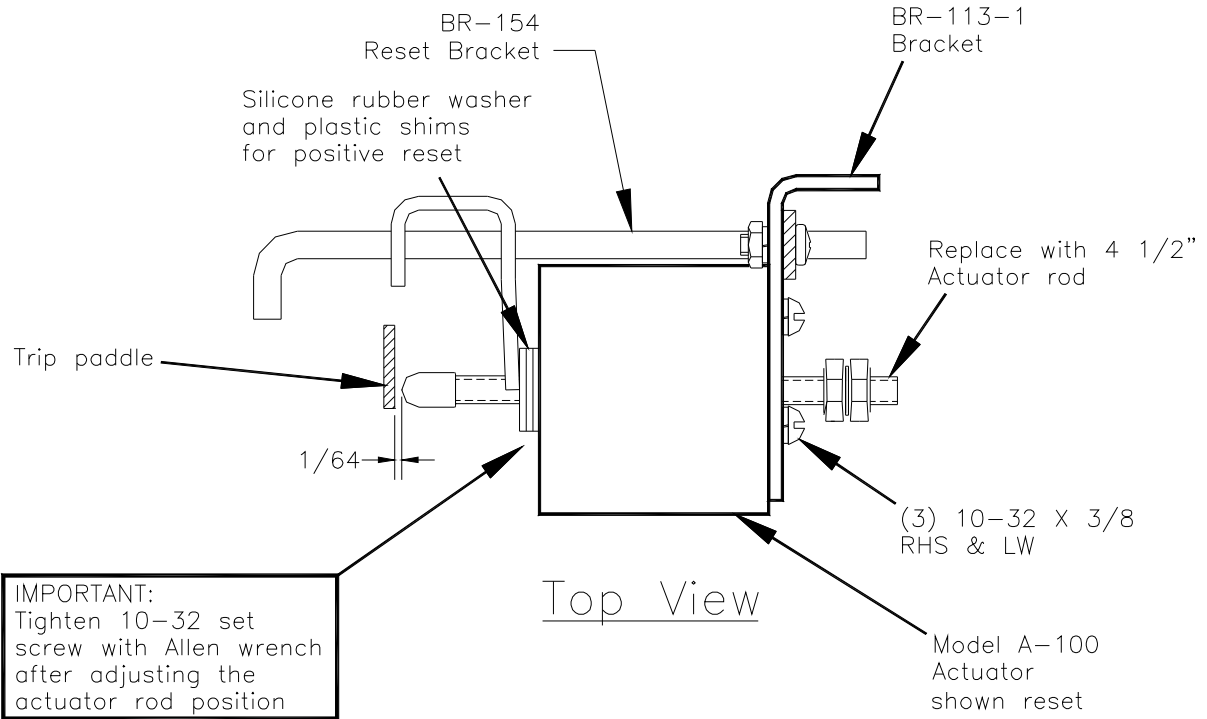

FIGURE 9
Actuator Bracket Installation
Front View



← Breaker Front

Shown with springs charged and breaker closed.

FIGURE 10
Actuator Installation
"Steel" Front

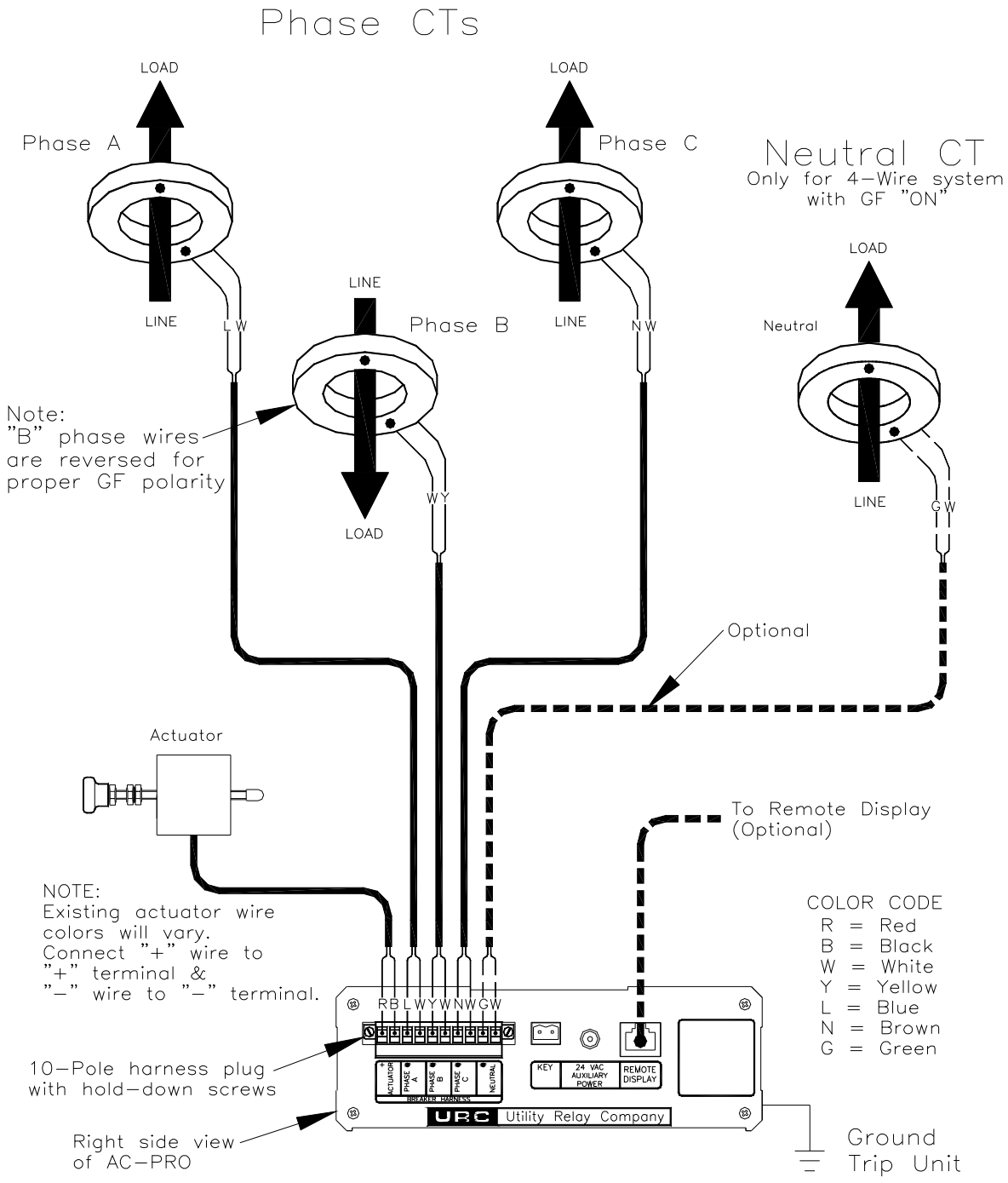

FIGURE 11
New Current Transformers
Wiring Diagram

IMPORTANT:
 The power winding portion of the existing LimiTrip CTs must be jumpered. (BLUE & GREEN leads)
 The signal winding portion of CTs must NOT be connected in common.

IMPORTANT:
 If the CTs are staggered, reverse the wiring on the "odd" CT for proper ground fault polarity.

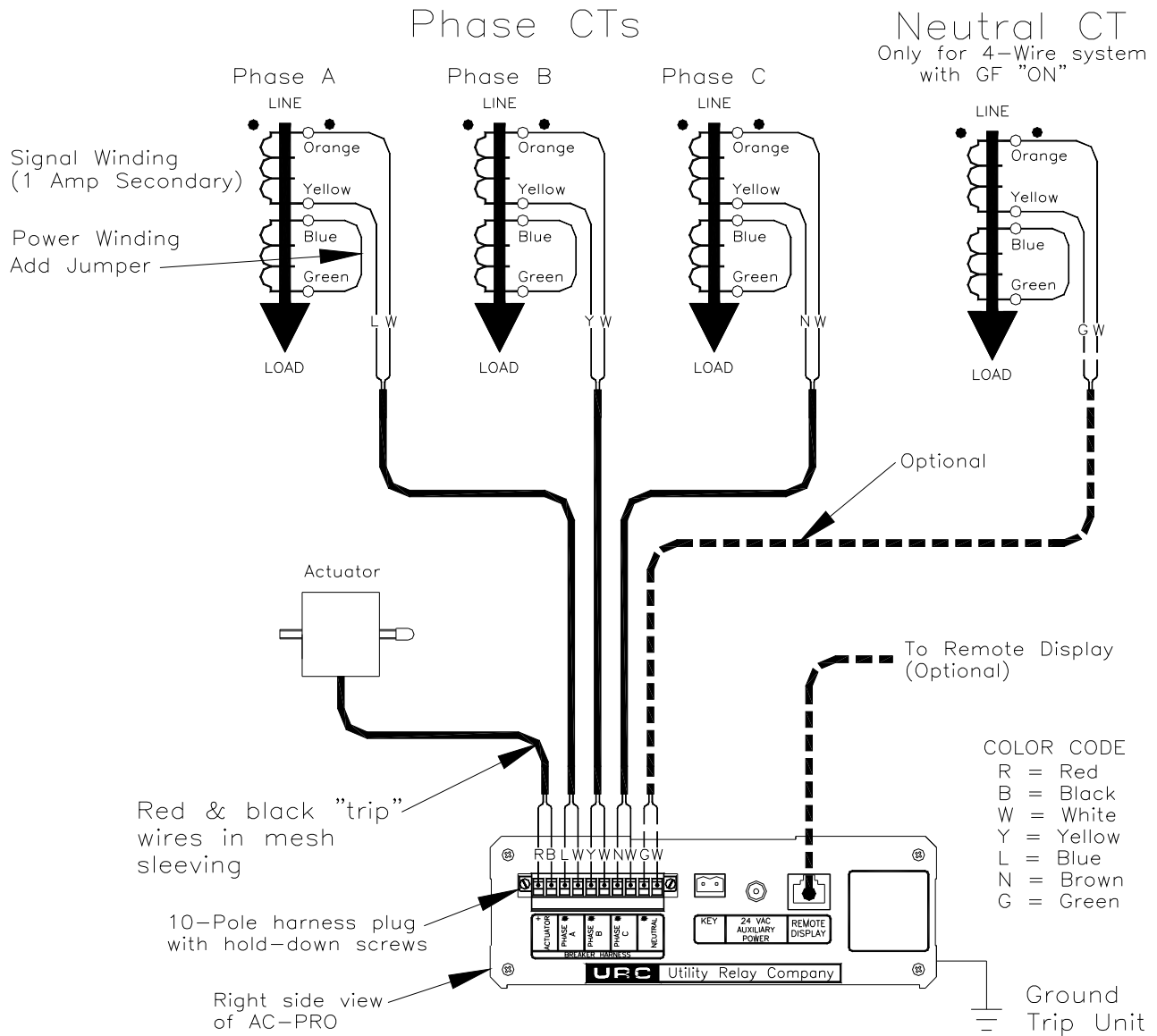

FIGURE 12
Limi-Trip Current Transformers
Wiring Diagram
 Page 26

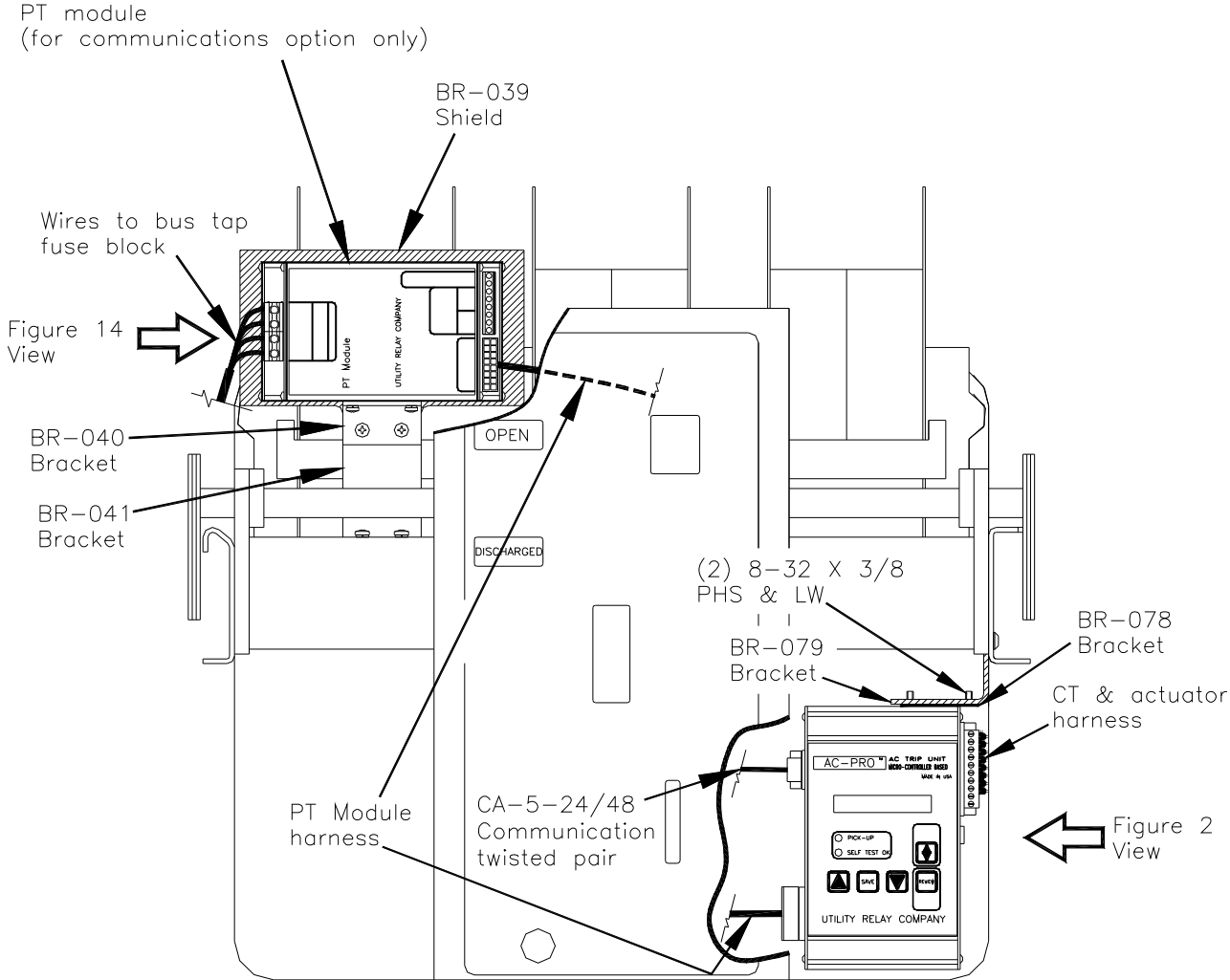

Figure 13
Front View
With Communications

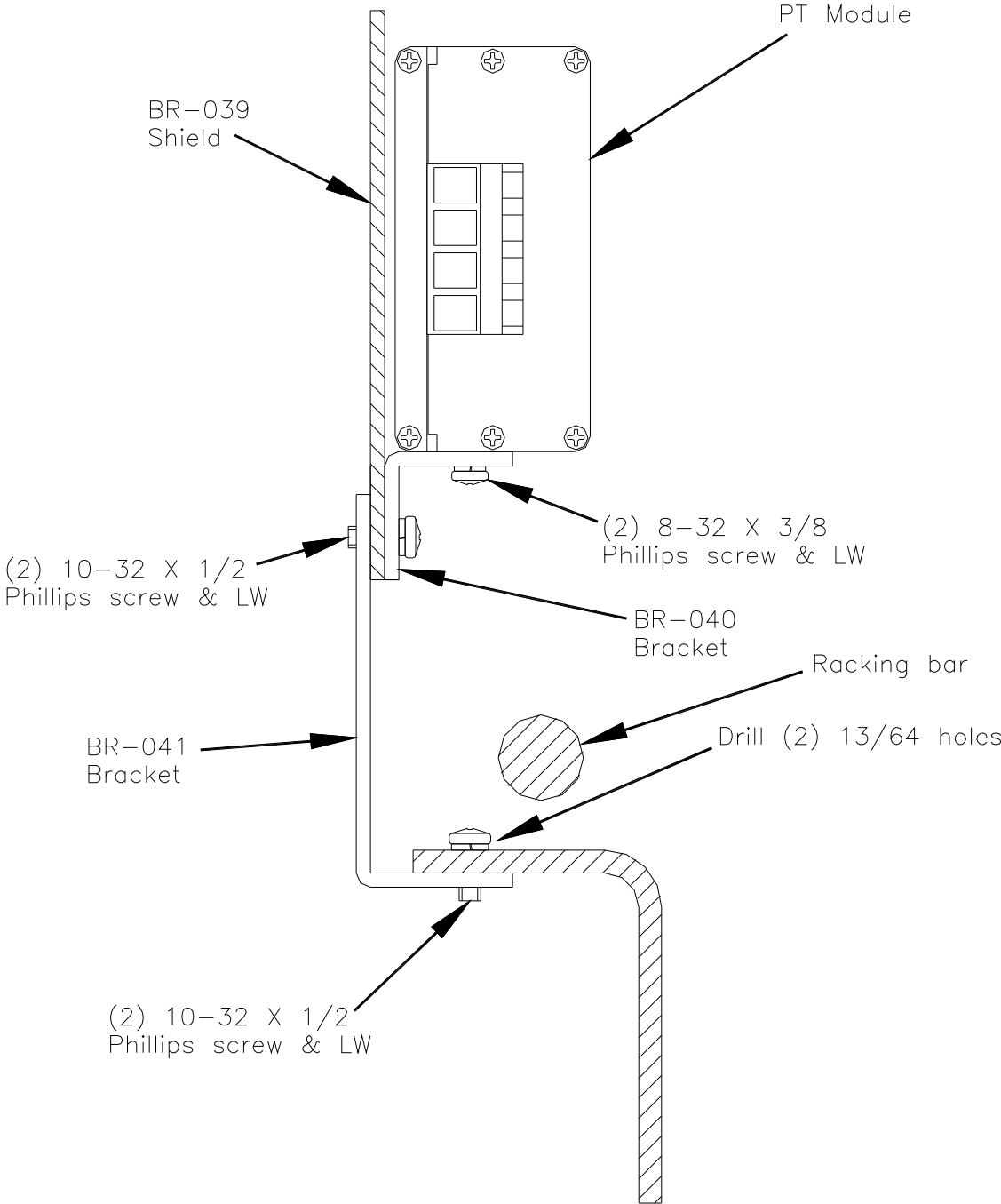

Figure 14
PT Module Installation
Page 28

