

AC-PRO Retrofit Kit

Direct Replacement Instructions
for:

Whipp & Bourne

International Circuit Breaker Co.

Navy Type ACB-1600/2000 HR

3P, 500Vac, 60Hz Circuit Breaker

Part No. 4284020-T

Utility Relay Co.

Chagrin Falls, Ohio 44023

Phone: 888-289-2864 Fax: 440-708-1177

www.utilityrelay.com

LIMITED WARRANTY

Utility Relay Company warrants that every AC-PRO and ZERO-Hertz trip unit and related retrofit kit components (herein collectively referred to as "product") shall be free from defects in material and workmanship, and will perform as described in Utility Relay Company's sales literature and Instruction Manuals, under normal use and service for a period of (2) two years from date of invoice.

Should any warranty claim arise within the warranty period, contact Utility Relay Company at 888-289-2864 and do the following:

- 1.) Provide a complete description of the problem with the trip unit or retrofit kit component.
- 2.) Provide the Serial Number located on the back of the trip unit from the warranted retrofit kit.
- 3.) Obtain a Returned Materials Authorization number (RMA) and return shipping instructions.
- 4.) Promptly return the defective material to Utility Relay Company.

Warranty Disclaimer and Liability Limitation

Utility Relay Company will repair or replace the trip unit and/or retrofit component(s) at no cost to the customer. The customer is liable and shall pay for shipment of defective products back to Utility Relay Company.

Excluded from this warranty and not warranted by Utility Relay Company in any fashion, either expressed or implied are:

- 1.) Any product which has been disassembled (except to replace batteries), repaired, tampered with, altered, changed, or modified by persons other than Utility Relay Company's own authorized service personnel unless repair by others is made with the written consent of Utility Relay Company.
- 2.) Defects or damage to the Product resulting from wear, tear, misuse, negligence, improper storage, improper testing, impacts, or use with non-approved accessories.
- 3.) Products used for any other purpose other than originally intended by Utility Relay Company.

TABLE OF CONTENTS

	PAGE
Section 1.0	General..... 1
1.1	Inspection..... 1
1.2	Variation from Standard AC-PRO..... 2
2.0	Initial Breaker Tests..... 3
3.0	Remove Existing Trip Unit 4280002-8..... 4
4.0	Commission AC-PRO Trip Unit..... 5
4.1	Enter Commissioning Routine..... 5
4.2	CT Rating..... 6
4.3	Long Time (LT) Pick-Up Setting..... 7
4.4	Short Time (ST) Pick-Up Setting..... 8
4.5	Short Time (ST) Delay..... 8
4.6	Saving Settings..... 9
5.0	Install AC-PRO Direct Replacement Trip Unit. 10
6.0	Operator Interface..... 11
6.1	Reviewing Settings & Last Trip Data... 11
6.2	Erasing Last Trip Data..... 11
6.3	"Tripped on Overcurrent" Illuminated Push Button..... 12
7.0	Final Test..... 13

ILLUSTRATIONS

Figure 1	Breaker Front View 14
2	AC-PRO Direct Replacement Trip Unit, Front View 15
3	AC-PRO Direct Replacement Trip Unit, Rear View 16
4	Breaker Harness & Secondary Injection Test Connectors, Detail View..... 17
5	AC-PRO Secondary Injection Test Set 18
6	Overall Schematic 19
7	Time Current Curves 20

AC-PRO Retrofit..... Whipp & Bourne NAVY Type ACB

Direct Replacement For Whipp & Bourne Trip Unit In NAVY Type ACB-1600/2000HR

1.0 General

All possible contingencies which may arise during the installation, operation or maintenance, and all details and variations of this equipment not necessarily covered by these instructions.

1.1 Inspection

Carefully inspect the AC-PRO direct replacement trip unit on arrival. If any damage is found, file a claim with the carrier and contact Utility Relay Co. for replacement parts.

Verify that this is the correct direct replacement trip unit for the circuit breaker being retrofitted.

Thoroughly read and understand these installation instructions as well as the AC-PRO trip unit instruction manual before proceeding with the retrofit.

AC-PRO Retrofit..... Whipp & Bourne NAVY Type ACB

1.2 Variation from Standard AC-PRO Trip Unit

This version of the AC-PRO trip unit has modified firmware to match the settings of the Whipp & Bourne Navy type ACB trip unit and some hardware modifications required by the breaker.

The AC-PRO instruction manual included in this kit applies to the normal version of the AC-PRO trip unit. This version differs in the following ways:

- Battery location
- Security "Key" location
- Remote display in not available
- Settings match the Whipp & Bourne Navy type ACB trip unit
- Time-Current curves match the Whipp & Bourne Navy type ACB trip unit

Please follow the instructions in this installation manual for the above differences.

2.0 Initial Breaker Tests

Before starting the retrofit, perform a visual/mechanical inspection and an electrical test of the circuit breaker removable element to determine its condition.

Refer to the breaker NAVSEA instruction documents and accepted test standards such as the NETA Maintenance Specifications or PEARL Reconditioning Standards to verify that the breaker is in acceptable mechanical and electrical operating condition.

As a minimum, perform the following:

- a) Close and trip operation of the breaker.
- b) Measure contact resistance of each pole.
- c) Measure insulation resistance from pole to pole, from pole to frame and across open contacts.
- d) Check contact compression.
- e) Check for sufficient finger cluster spring tension at the rear stabs.

Rectify any abnormalities found. Clean and lubricate the breaker as required.

3.0 Remove the Existing Trip Unit

To facilitate the removal of the existing trip unit, Whipp & Bourne Part No. 4280002-8, and the installation of the replacement trip unit, it is suggested that the breaker be placed on a sturdy workbench and safely blocked up a few inches to improve access to the trip unit.

Remove the existing trip unit as follows:

- 1) Remove the four (8) Hex Cap screws attaching the ends of the trip unit to the breaker.
- 2) Slide the trip unit forward and down slightly.
- 3) Disconnect the secondary injection test connector by removing the four (4) Flat Head screws.
- 4) Remove the two (2) Flat Head screws attaching the breaker wiring harness to the connector tie bar and disconnect the breaker wiring harness connector.

AC-PRO Retrofit..... Whipp & Bourne NAVY Type ACB

4.0 Commission the AC-PRO Trip Unit

Before the AC-PRO trip unit is placed in service, it must first be commissioned so it will function. To commission the trip unit, enter the CT rating and all the pick-up and delay settings into the trip unit as outlined below.

It is easier to commission the AC-PRO trip unit before it is installed on the breaker.

IMPORTANT: The AC-PRO trip unit will NOT FUNCTION as it is shipped from the factory.
The trip unit must first be COMMISSIONED.

4.1 Enter Commissioning Routine

With the AC-PRO trip unit not powered up,

1. Push and hold the Programming Push button
(See Figure 3).
2. Push the "REVIEW" push button.
This will power up the trip unit from the Lithium battery and the following will be alternately displayed:

ENTER DATA

SN: xxxxxxxxxxxx

Where xxxxxxxxxxxx is the serial number.

3. Push the "SAVE" push button.
The following will be displayed:

PRO AC10Vx.xx.xx

Where x.xx.xx is the firmware revision number.

4. The Programming Push button can now be released.
5. Push the "SAVE" push button to advance to the CT rating.

4.2 CT Rating

The CT rating entered into the trip unit should match the actual rating of the phase CTs in the cell that the breaker will be used.

If the CT rating entered in the trip unit does not match the actual CT rating of the breaker, then the following will happen:

- The LT Pick-Up setting will still be correct
- The ST Pick-Up setting & delay will still be correct
- The currents displayed on the trip unit will not be correct
- The currents for the last trip data will not be correct

The following will be displayed:

CT RATING xxxxA

Where "xxxx" represents the CT primary rating in amps. The CT rating can range from 50 amps to 5,000 amps in 25 amp steps and 5250 amps to 6000 amps in 250 amp steps.

A security feature is provided so that the CT rating will not be accidentally changed later.

1. Simultaneously push and release both the "SAVE" and "REVIEW" push buttons. This defeats the security feature and allows the CT rating to be changed.
2. Press and hold the "UP" or "DOWN" push button as required until the correct CT rating is displayed.
3. Push the "SAVE" push button to advance to LT pick-up setting.

4.3 Long Time (LT) Pick-Up Setting

The following will be displayed:

LT PICK-UP xxx%

Where "xxx" represents the LT pick-up setting in percent of the CT rating. The LT pick-up settings are 150%, 200% and 250%.

1. Press and hold the "UP" or "DOWN" push button as required until the correct LT pick-up setting is displayed.
4. Push the "SAVE" push button to advance to ST pick-up setting.

4.4 Short Time (ST) Pick-Up Setting

The following will be displayed:

ST PICK-UP xxx%

Where "xxx" represents the ST pick-up setting in percent of the CT rating. The ST pick-up settings are 200%, 250%, 300%, 400% and 500%.

2. Press and hold the "UP" or "DOWN" push button as required until the correct ST pick-up setting is displayed.
5. Push the "SAVE" push button to advance to ST delay setting.

4.5 Short Time (ST) Delay

The following will be displayed:

ST DELAY .xxS

Where ".xx" represents the ST delay setting seconds. The ST delay settings are .10S, .20S, .30S and .40S.

3. Press and hold the "UP" or "DOWN" push button as required until the correct ST delay setting is displayed.
6. Push the "SAVE" push button to advance to saving settings.

4.6 Saving Settings

The following will be alternately displayed:

SAVE KEY IF DONE

REVIEW TO REVIEW

If it is desired to review the settings, push the "REVIEW" push button. Make any changes necessary using the "UP" or "DOWN" push buttons. AS before use the "SAVE" push button to move to each new setting.

If the settings are as desired, push the "SAVE" push button. The settings are saved in non-volatile memory and the trip unit shuts off.

NOTE: To change the AC-PRO trip unit settings, the breaker must be removed from service to gain access to the Programming Push button.

5.0 Install AC-PRO Direct Replacement Trip Unit

Install the AC-PRO direct replacement trip unit as follows:

- 1) Slide the trip unit into position in the breaker with the trip unit tilted forward so just the lower rear mounting holes of the trip unit line up.
- 2) Loosely attach the trip unit with one (1) 1/4-20 X 1/2 hex cap screw and lock washer in each lower rear mounting hole.
- 3) Reach in over the trip unit and attach the secondary injection test set connector to the inside of the breaker frame using four (4) 4-40 X 1/2 flat head screws, lock washers and hex nuts.
- 4) Carefully rotate the trip unit into position verifying that all wiring is properly positioned and there are no interferences.
- 5) Add the remaining six (6) 1/4-20 X 1/2 hex cap screws and lock washers for the trip unit mounting and firmly tighten all hardware.
- 6) From underneath the breaker, plug the breaker wiring harness connector into the mating connector in the trip unit and secure with two (2) 4-40 X 1/2 flat head screws. Lock in place with a lock washer and hex nut.

<p>Note: The connectors are polarized at the number 1 pin.</p>
--

6.0 Operator Interface

The method required to enter the settings is slightly different from the standard AC-PRO trip unit as described in the attached AC-PRO manual. Also, a "Tripped on Overload" illuminated push button is provided.

6.1 Reviewing Settings & Last Trip Data

Once commissioned, use the "REVIEW" push button to review the programmed settings and last trip data.

6.2 Erasing Last Trip Data

To erase the last trip data...

Push the "REVIEW" button just once. The last trip data will be displayed. As an example:

LAST TRIP	ST
PHASE A	xxxxxA
PHASE B	xxxxxA
PHASE C	xxxxxA

Where "xxxxx" is the current at time of trip in amps.

While the last trip data is being displayed, push and hold both the "UP" and "DOWN" pushbuttons and momentarily push the "SAVE" button. Release the buttons.

The following will now be displayed.

NO LAST TRIP

The trip counter will also be cleared.

6.3 *"Tripped on Overcurrent" Illuminated Push Button*

A "Tripped on Overcurrent" illuminated push button is provided.

The lamp in the illuminated push button is controlled by a latching relay on the same circuit board as the programming push button. When the AC-PRO does a trip it fires the breaker actuator and also momentarily energizes the latching coil of the latching relay. When the relay is in the latched position the lamp is illuminated using the 24Vac from a breaker-mounted transformer. Pushing the "Tripped on Overcurrent" button energizes the reset coil in the latching relay turning off the lamp. The 24Vac from the breaker is also used for the reset coil.

When testing with the secondary injection test set, the "Tripped on Overcurrent" illuminated push button does not operate unless 24Vac is connected to pins 9 & 14 of the breaker harness connector.

When a breaker is first placed in service the "Tripped on Overcurrent" lamp may be illuminated due to a previous secondary injection trip that left the latching relay in the latched position. Pushing the "Tripped on Overcurrent" button will unlatch the relay and turn off the lamp.

7.0 Final Test

Perform a final electrical test of the breaker as in Section 1.

A primary injection test is normally recommended as the final test of an AC-PRO retrofit. With this breaker, however, a primary injection test is not practical because the CTs are located in the breaker cell and not on the breaker itself.

A secondary injection test is the most practical test of the AC-PRO direct replacement.

Connect the AC-PRO Secondary Injection Test Set to the test connector as shown in Figure 5.

Refer to the Secondary Injection Test Set manual for instructions on testing.

AC-PRO Retrofit..... Whipp & Bourne NAVY Type ACB

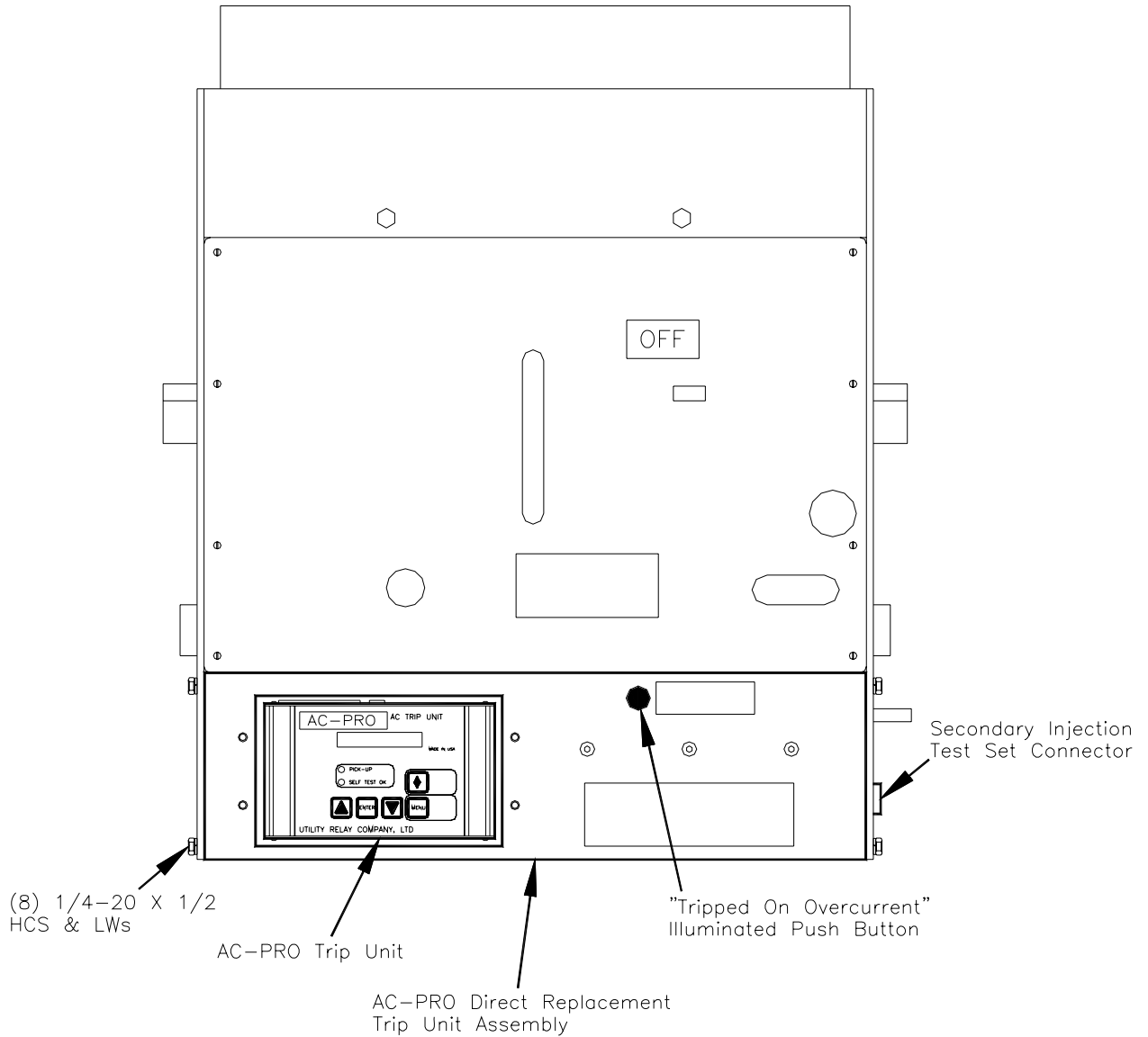

FIGURE 1
Breaker Front View
With AC-PRO Direct Replacement Trip Unit
Page 14

AC-PRO Retrofit..... Whipp & Bourne NAVY Type ACB

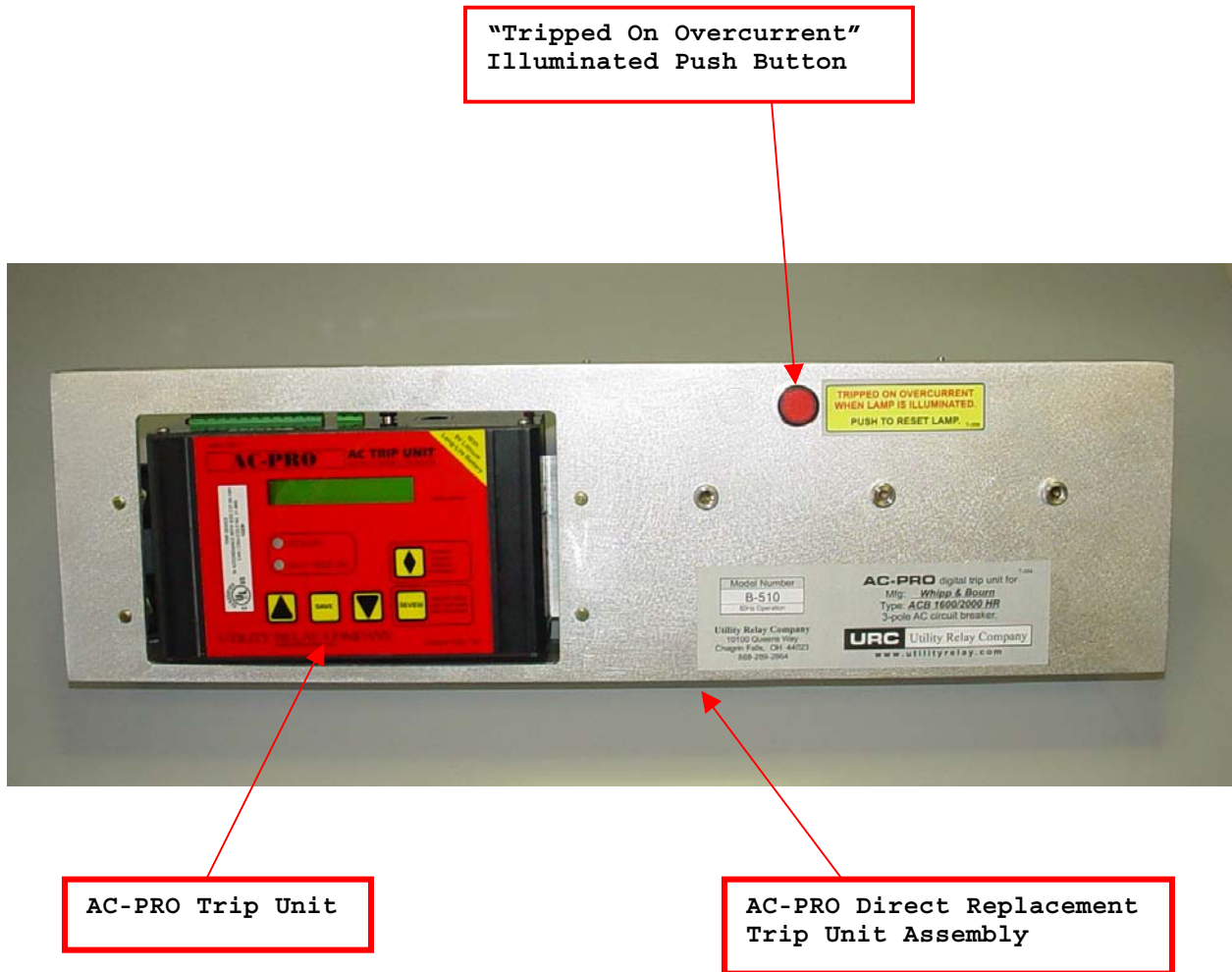

FIGURE 2
Front View
AC-PRO Direct Replacement Trip Unit
Page 15

AC-PRO Retrofit..... Whipp & Bourne NAVY Type ACB

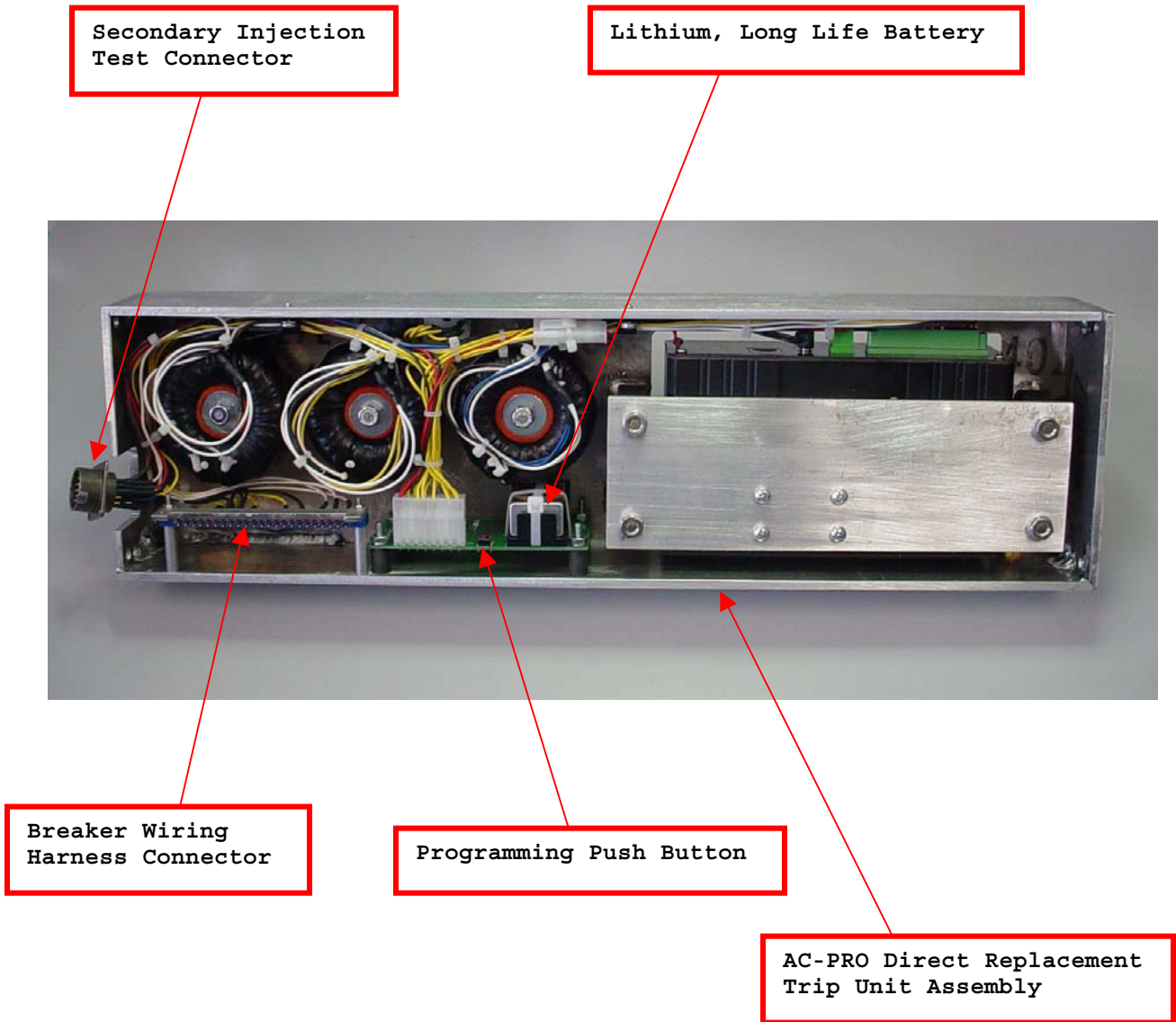
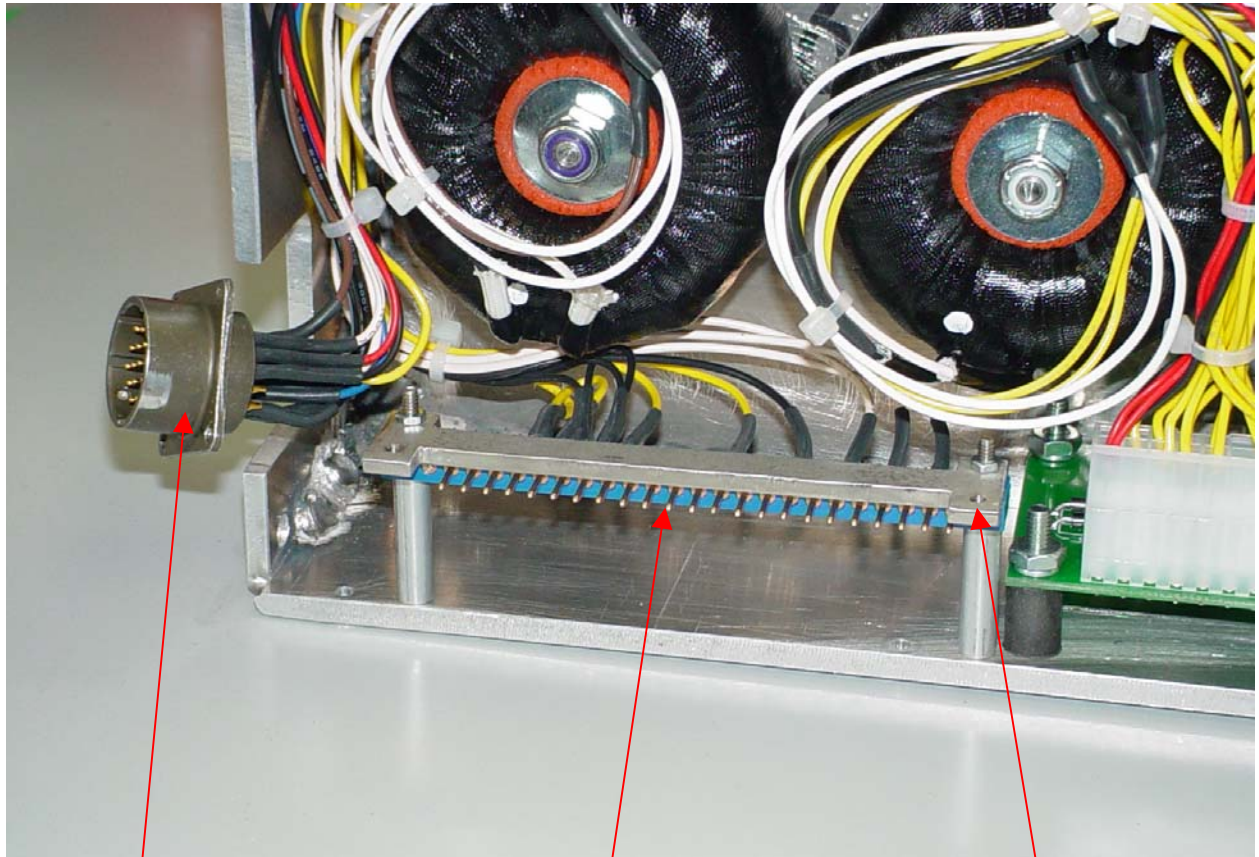

FIGURE 3
Rear View
AC-PRO Direct Replacement Trip Unit



Secondary Injection
Test Connector

Breaker Wiring
Harness Connector

Connector
Tie Bar

FIGURE 4
Detail View
Breaker Harness & Secondary Injection Test Connectors

AC-PRO Retrofit..... Whipp & Bourne NAVY Type ACB

AC-PRO Secondary Injection Test Set



AC-PRO Direct Replacement Trip Unit Assembly

Secondary Injection Test Connector

FIGURE 5
AC-PRO Secondary Injection Test Set
Page 18

AC-PRO Retrofit..... Whipp & Bourne NAVY Type ACB

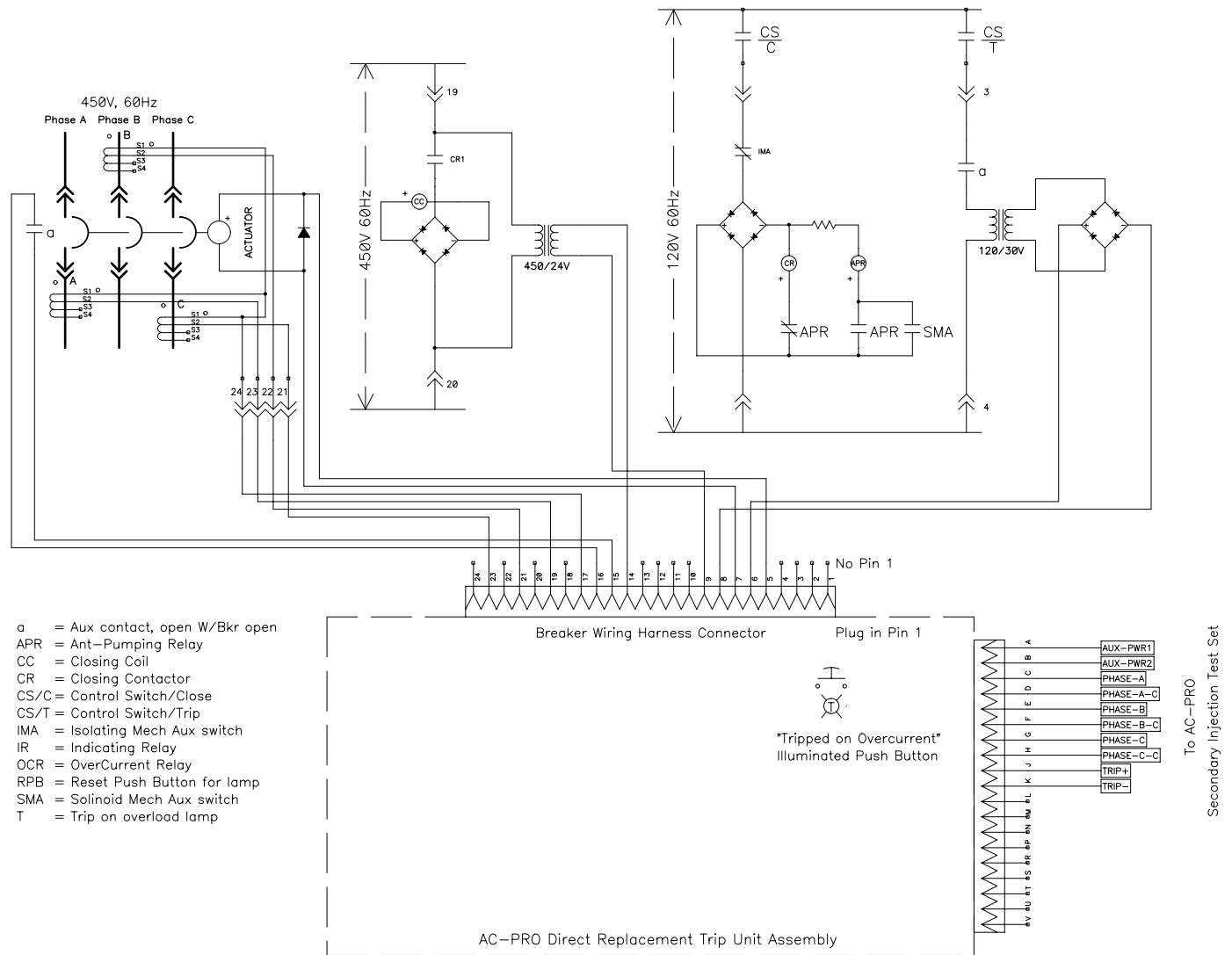

FIGURE 6
Overall Schematic

AC-PRO Retrofit..... Whipp & Bourne NAVY Type ACB

AC-PRO Trip Unit for
Whipp & Bourne Navy Type ACB-1600/2000HR-3200/4000HR

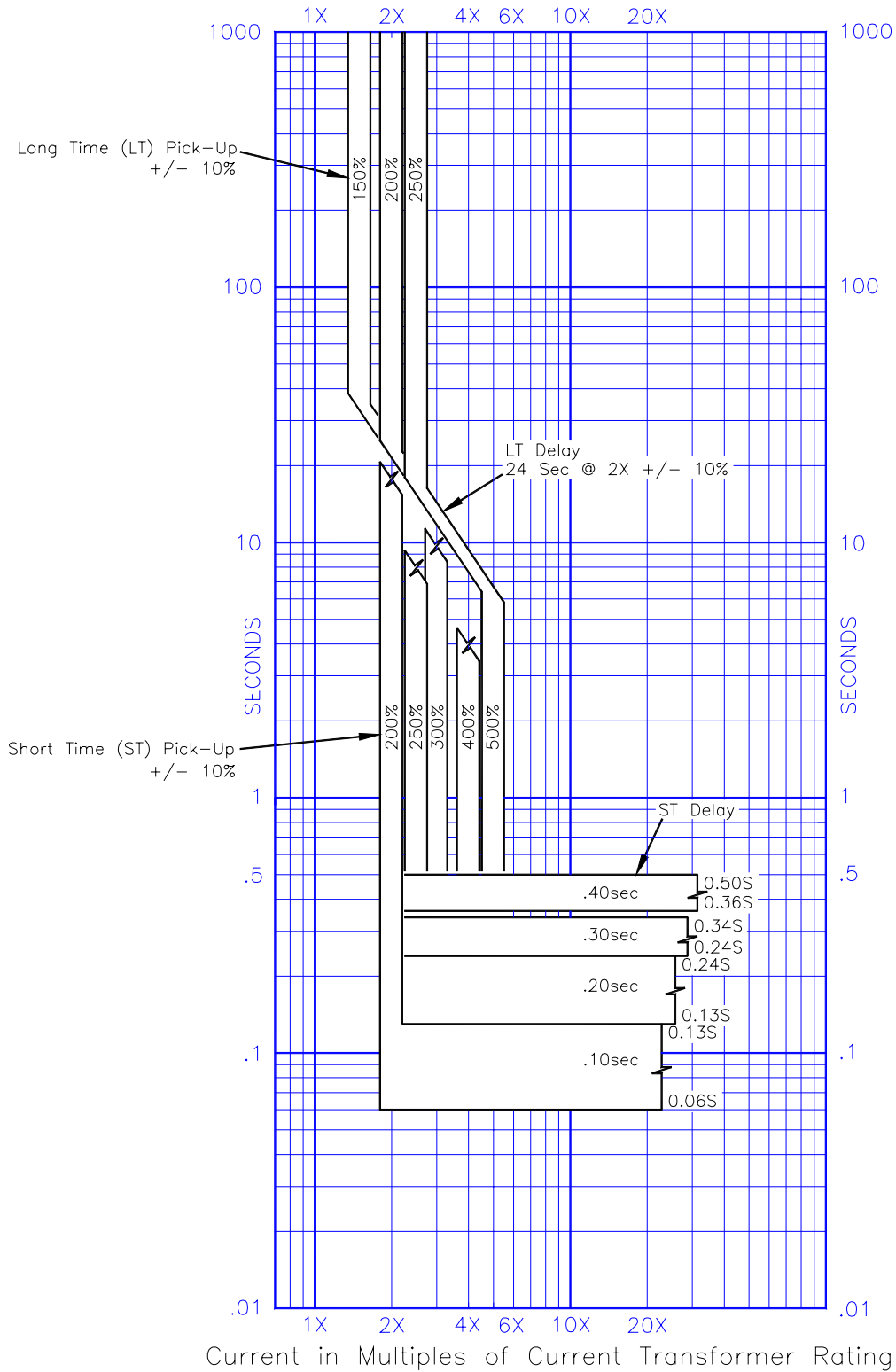

FIGURE 7
Time Current Curves