

AC-PRO[®]

I-AC-PRO-QT

AC TRIP UNIT

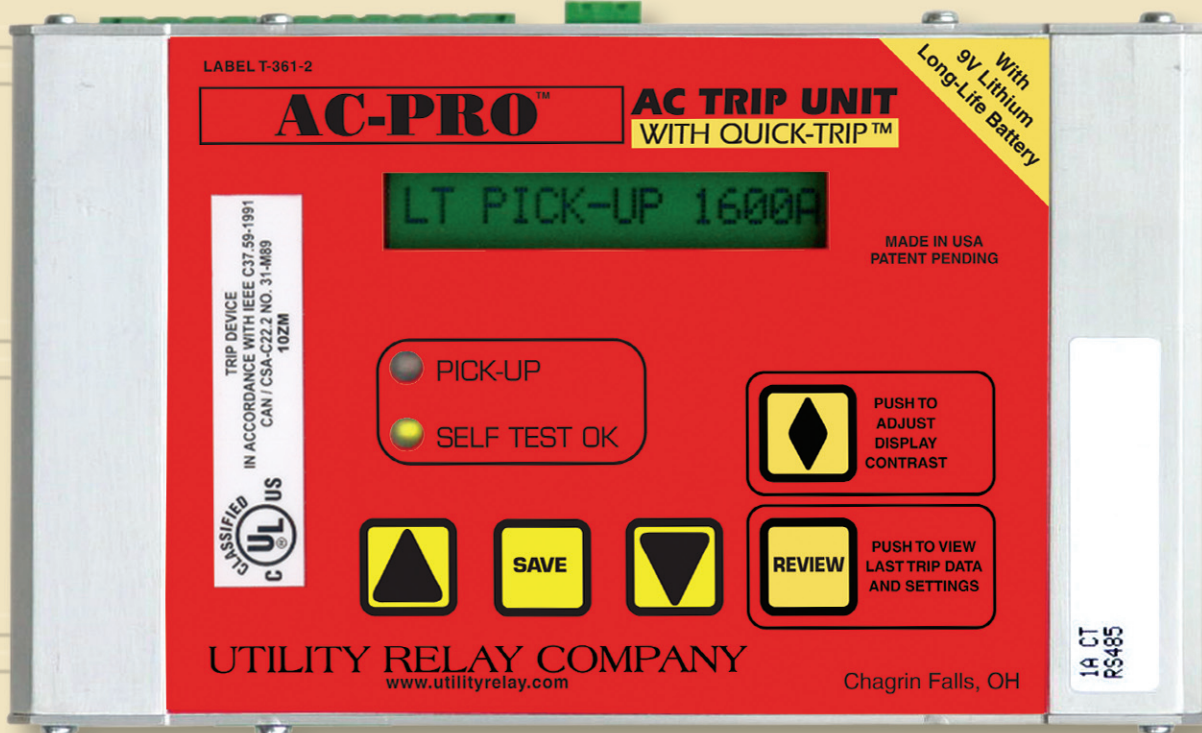

INSTRUCTION MANUAL

State of the art technology for low voltage circuit breaker retrofitting

URC Utility Relay Company

Chagrin Falls, OH 44023
Phone: 888.289.2864
www.utilityrelay.com

Manual Rev 1.2

Section:	Page		
1.0	Introduction	2	
2.0	UL/ULC Classification	2	
3.0	Trip Unit Power	2	
3.1	Current Transformer (CT) Power	2	
3.2	Battery Power	2	
3.3	PT Module Power	3	
3.4	Auxiliary Power	3	
4.0	External Connections	3	
4.1	Breaker Wiring Harness	3	
4.2	Security Key	3	
5.0	AC-PRO™ Front View	4	
5.1	16 Character Display	5	
5.2	Pick-Up LED	5	
5.3	Self Test LED	5	
5.4	Display Contrast	5	
5.5	UP Push Button	5	
5.6	DOWN Push Button	5	
5.7	SAVE Push Button	5	
5.8	REVIEW Push Button	5	
6.0	QUICK-TRIP™ System	6	
6.1	QUICK-TRIP™ Basics	6	
6.2	QUICK-TRIP™ Installation	7	
6.3	QUICK-TRIP™ & Pro-Display Operation	8	
7.0	Commissioning the AC-PRO™	8	
7.1	Powering-Up the Trip Unit	8	
7.2	Security Key	8	
7.3	CT Rating	9	
7.4	Long Time (LT) Pick-Up Setting	9	
7.5	Long Time (LT) Delay Setting	9	
7.6	Short Time (ST) Pick-Up Setting	9	
7.7	Short-Time (ST) Delay Setting	9	
7.8	Short Time (ST) I ² T	9	
7.9	Instantaneous (I) Pick-Up Setting	10	
7.10	Ground Fault (GF) Pick-Up Setting	10	
7.11	Ground Fault (GF) Delay Setting	10	
7.12	Ground Fault (GF) I ² T	10	
7.13	Phase Unbalance (U/B) Pick-Up	10	
7.14	Phase Unbalance (U/B) Delay	10	
7.15	Address	11	
7.16	Reply Delay	11	
7.17	QUICK-TRIP™ Ground Fault (QT GF)	11	
7.18	QUICK-TRIP™ Instantaneous (QT I)	11	
7.19	Thermal Memory	12	
7.20	Exit Procedure	12	
8.0	Changing Settings	13	
9.0	Last Trip Data Recall	14	
10.0	Normal Operation	15	
11.0	Testing	15	
11.1	Commission the Trip Unit	15	
11.2	LT Trip Test	15	
11.3	ST Trip Test	16	
11.4	I Trip Test	16	
11.5	GF Trip Test	16	
11.6	QT GF Trip Test	16	
11.7	CT Phasing Test for GF	16	
11.8	QT I Trip Test	17	
11.9	U/B Trip Test	17	
11.10	Erase Last Trip Data	17	
12.0	Secondary Injection Testing	18	
12.1	AC-PRO™ Secondary Injection Test Set	18	
12.2	Standard Relay Test Set	18	
12.3	LT Delay Testing Chart	19	
13.0	Ratings	20	
14.0	Warranty	20	
15.0	Time-Current Curves	20	
15.1	LT Trip Time	21	
15.2	ST Trip Time	21	
15.3	GF Trip Time	22	
15.4	U/B Trip Time	22	
16.0	Error Message Summary	22	
16.1	Actuator Not Connected	22	
16.2	Memory Error	22	
Figure:			Page
4.1	AC-PRO™ Top View	3	
5.1	AC-PRO™ Horizontal Front View	4	
5.2	AC-PRO™ Vertical Left Front View	4	
6.1	QUICK-TRIP™ Connections	6	
6.2	QUICK-TRIP™ Drilling Plan	7	
6.3	Pro-Display Mounting	7	
11.1	Phase A & B, CT Phasing Test	16	
11.2	Phase B & C, CT Phasing Test	16	
11.3	U/B Test	17	
12.1	AC-PRO™ Secondary Injection Test Set	18	
17.1	Typical Wiring Diagram	23	
17.2	Overload TCC	25	
17.3	U/B & GF TCC	27	
17.4	QUICK-TRIP™ GF & I TCC	29	
Firmware Revision: 5.10			

1.0 Introduction

The AC-PRO is a state of the art, micro-controller based trip unit for use on three phase, 600 Volt class, AC circuit breakers. Models are available for use on 60 Hz, 50 Hz, 40 Hz, and 25 Hz systems.

The AC-PRO is a digital trip unit that uses a micro-controller and a 16-character liquid crystal display (LCD).

The trip unit provides over-current, as well as short time and instantaneous fault protection. **All of the phase protection functions use the true RMS currents including the instantaneous trip function.**

The AC-PRO measures the true RMS current through each of the breaker's three poles. For ground fault current, the trip unit also does a vector sum of the three phase currents (and neutral current if applicable) and determines the fundamental frequency component.

The trip unit also offers ground fault and phase unbalance (U/B) tripping functions as user selectable options. **The fundamental value of the ground fault current is used for the ground fault trip function to eliminate nuisance ground fault trips due to multiples of the 3rd harmonic.**

The AC-PRO also has two additional QUICK-TRIP protective settings that are intended to minimize **Arc Flash Hazard**. The QUICK-TRIP ground fault and instantaneous trip functions are turned ON or OFF using the QUICK-TRIP Pro-Display. See Section 6.0 for complete details.

The trip unit stores the last trip data and the trip log data in a non-volatile FRAM memory for later recall. All the settings are stored in non-volatile EEPROM memory. Battery backup is not required.

The trip unit does not require external power to operate. Power is derived from the current transformers (CTs). An internal battery provides power to review and change protection settings when CT power is unavailable.

All settings are made directly in **amps** or in **seconds**. A security system reduces the risk of unauthorized tampering with the trip unit settings.

2.0 UL/ULC Classification

AC-PRO is UL and ULC classified for use on the following low voltage AC power circuit breakers:

Westinghouse DB-50
General Electric AK-50
General Electric AK-75

UL and ULC classification is in accordance with UL1066, CSA C22.2, IEEE C37.59-1991 as well as appropriate sections of ANSI C37.17-1979 and C37.50-1989.

AC-PRO was tested by an independent laboratory and found in compliance with the following tests:

IEEE C37.90.2-2004, RF Susceptibility
IEEE C37.90.1-2002, Surge Withstand
15KV Electro-Static Discharge
Accuracy @ -20°C & +65°C

3.0 Trip Unit Power

The AC-PRO can be powered in 4 different ways: CTs, internal battery, PT module, or auxiliary power pack.

3.1 Current Transformer (CT) Power

The AC-PRO derives both signal and power from the breaker phase CTs. The trip unit will power-up with less than 10% of the rated CT tap current through a single CT (20% for the 1/2 Amp version). This current is below the lowest pick-up setting.

3.2 Battery Power

A 9-volt, 1200 mAh, long life, lithium/manganese dioxide battery is used in the trip unit. This battery has less than 2 grams of lithium. There are no restrictions on transport and no special methods of disposal required with this battery.

The battery is designed to provide two functions:

- 1) Allow the user to commission (program) the trip unit without using the auxiliary power pack.
- 2) Allow the user to recall the last trip data even if the breaker is open and without using the auxiliary power pack.

Press the "REVIEW" push button to turn the trip unit on under Battery power.

When on battery power, the trip unit will automatically turn off 30 seconds after the last button is pushed to conserve battery energy.

**** NOTE ****

The battery is NOT involved in the protective functions of the trip unit. The trip unit will provide protection even if the battery is removed.

The battery is NOT required for the trip unit to maintain any of its memory including the user programmed pick-up and delay settings or the last trip data.

Lithium battery ratings:

- Rated shelf life of ten-years
- 1200 mAh Capacity
(Allows the review of last trip data and settings over 1500 times on battery power only)

To gain access to the battery, remove the nine screws securing the top cover plate on the trip unit with a Torx T-10 screwdriver.

**** IMPORTANT ****

For best performance, replace with the following 9-volt lithium battery.

Ultralife Model U9VL-J

An alkaline type 9-volt battery may also be used with much shorter life.

The breaker must be removed from service before removing the top cover on the trip unit.

The replacement battery must be inserted with the proper polarity.

3.3 PT Module Power

The AC-PRO⁺ is the communication version of the AC-PRO trip unit and has a connection for a PT module.

The PT module provides breaker 3-Phase voltage information and also provides power for the trip unit independently from the CTs. See the Communication Instruction Manual for more information.

3.4 Auxiliary Power

Auxiliary power is optional. It can be used to change or review the trip unit settings without using the internal battery.

Plug the 24-VAC auxiliary power pack into the auxiliary power jack on the top of the trip unit.

The power pack is available from Utility Relay Company as part number T-390.

4.0 External Connections

The external connections are made to the top of the AC-PRO trip unit (or the left or right side for the vertical versions).

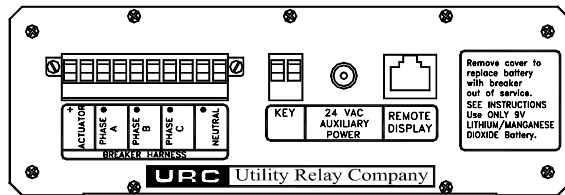

Figure 4.1 AC-PRO™ Top View

4.1 Breaker Wiring Harness

The breaker wiring harness connects the trip unit to the CTs and actuator. The wiring harness plugs into the 10-pin connector on the top of the trip unit and is retained with two screws.

	Function	Color Code
1	Actuator (+)	Red
2	Actuator (-)	Black
3	Phase A (Dot)	Blue
4	Phase A	White
5	Phase B (Dot)	Yellow
6	Phase B	White
7	Phase C (Dot)	Brown
8	Phase C	White
9	Neutral CT (Dot)	Green
10	Neutral CT	White

Table 4.1 Breaker Wiring Harness Pin-Out

A neutral CT wiring harness is provided as part of the neutral CT installation kit and is only required with ground fault on a 4-wire system. The ground fault function on a 3-wire system does not require a neutral CT.

4.2 Security Key

The AC-PRO trip unit contains a security feature that only allows someone familiar with the operation of the trip unit to commission the trip unit or make changes to the settings. A security key is required to change any of the settings.

The "Key" is simply a short jumper wire that is connected between the two terminals marked "KEY" on the top of the trip unit.

Refer to Figure 4.1 AC-PRO Top View.

To turn the security **Key "ON"**:

Jumper the two terminals labeled "KEY" on the top of the trip unit.

To turn the security **Key "OFF"**:

Remove the jumper wire.

The key allows the user to commission the trip unit or to change the settings on a trip unit by performing the steps as outlined in Sections 7.0 and 8.0.

The "CT Rating" also has an additional security feature as explained in Section 7.3.

5.0 AC-PRO™ Front View

The front view of the horizontal version of the AC-PRO trip unit is shown in Figure 5.1. The front view of a vertical version of the AC-PRO is shown in Figure 5.2.

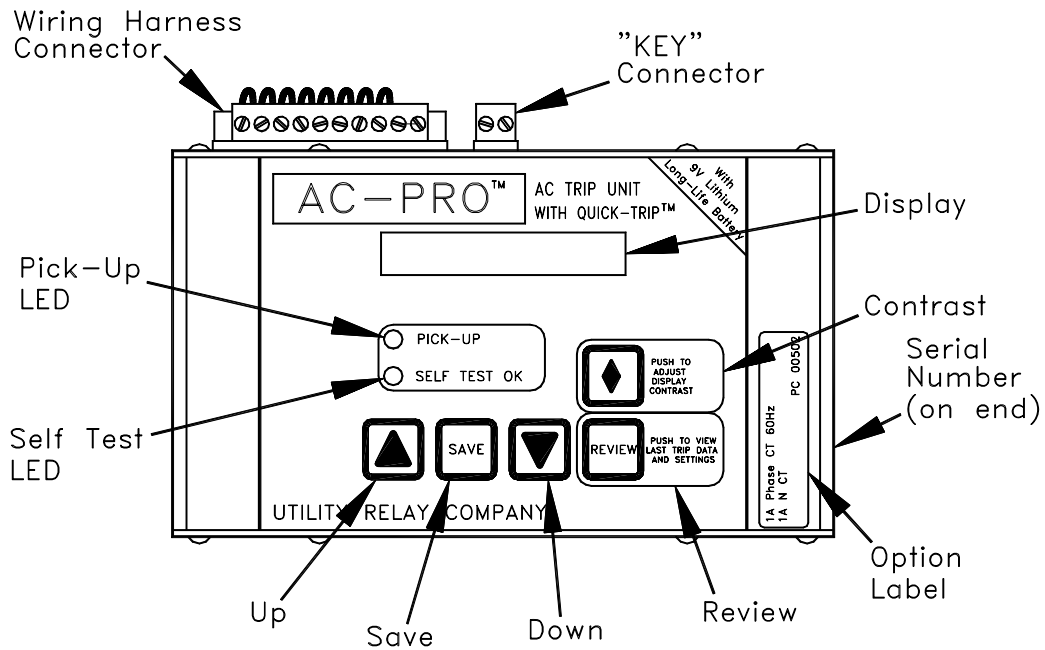

Figure 5.1 AC-PRO™ Horizontal Front View

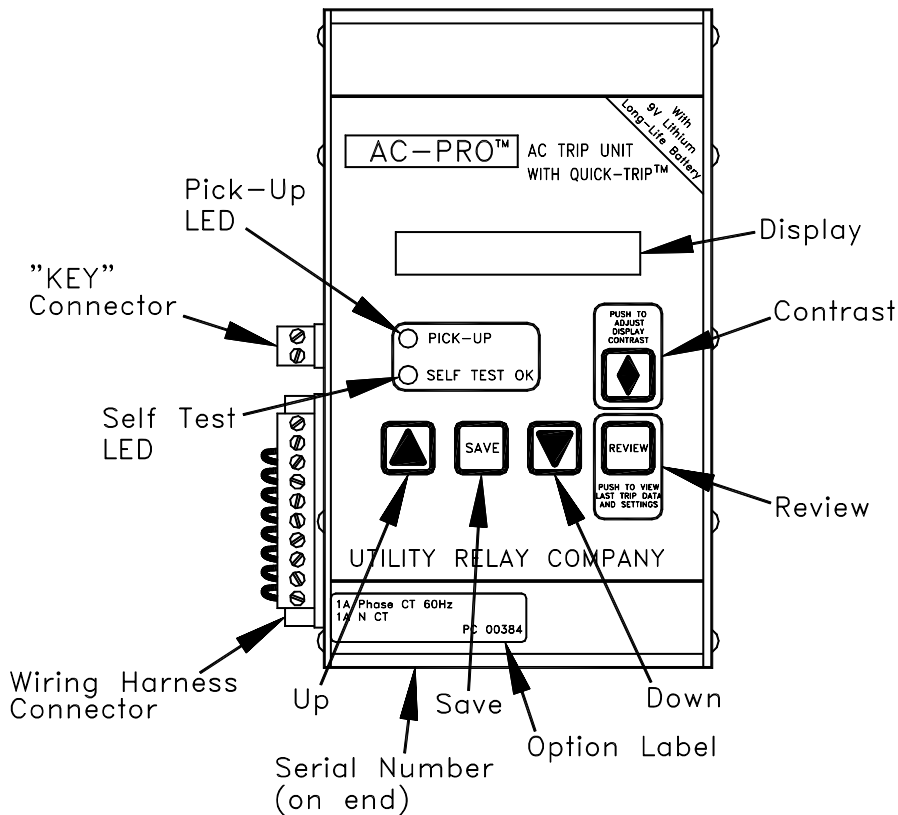

Figure 5.2 AC-PRO™ Vertical Left Front View

5.1 16 Character Display

A 16-character dot matrix liquid crystal display (LCD) provides information to the user.

The LCD is used for the following purposes:

- 1) Entering the CT rating and making the pick-up and time delay settings with prompts from the display.
- 2) Displaying, on demand, the CT rating and the various pick-up and delay settings.
- 3) Displaying, on demand, the reason for the last trip and the currents at the time of trip.
- 4) Continuously displaying the actual 3-phase AC currents on the breaker.

5.2 Pick-Up LED

The Pick-Up LED is normally off. It will turn on whenever the breaker current is above the LT Pick-up setting.

5.3 Self Test LED

The Self Test LED is normally on. It will turn off under the following conditions:

- 1) The actuator is not connected. The LCD will also display an error message.
- 2) There is a checksum error in the micro-controller. The LCD will also display an error message.

5.4 Display Contrast

The contrast level of the LCD can be adjusted by pressing this push button.

When the contrast push button is pressed and held, the display will begin to get either darker or lighter. To change direction, release the push button for more than one second, then press and hold the push button until the desired contrast is achieved.

5.5 UP Push Button

Use this push button to increase the setting values during commissioning. When the "UP" push button is held longer than one second, the settings are increased in fast mode.

When the maximum setting value is reached, the "UP" push button will have no further effect on the setting value.

5.6 DOWN Push Button

Use this push button to decrease the setting values during commissioning. When the "DOWN" push button is held longer than one second, the settings are decreased in fast mode.

When the minimum setting value is reached, the "DOWN" push button will have no further effect on the setting value.

5.7 SAVE Push Button

Use this push button to step through the settings when in the commissioning mode.

Holding this push button has no effect.

5.8 REVIEW Push Button

Use this push button to step through the settings in the settings review mode. Also use this push button to turn the trip unit on using battery power.

Hold this push button down to review trip counts during the settings review.

6.0 Quick-Trip™ System

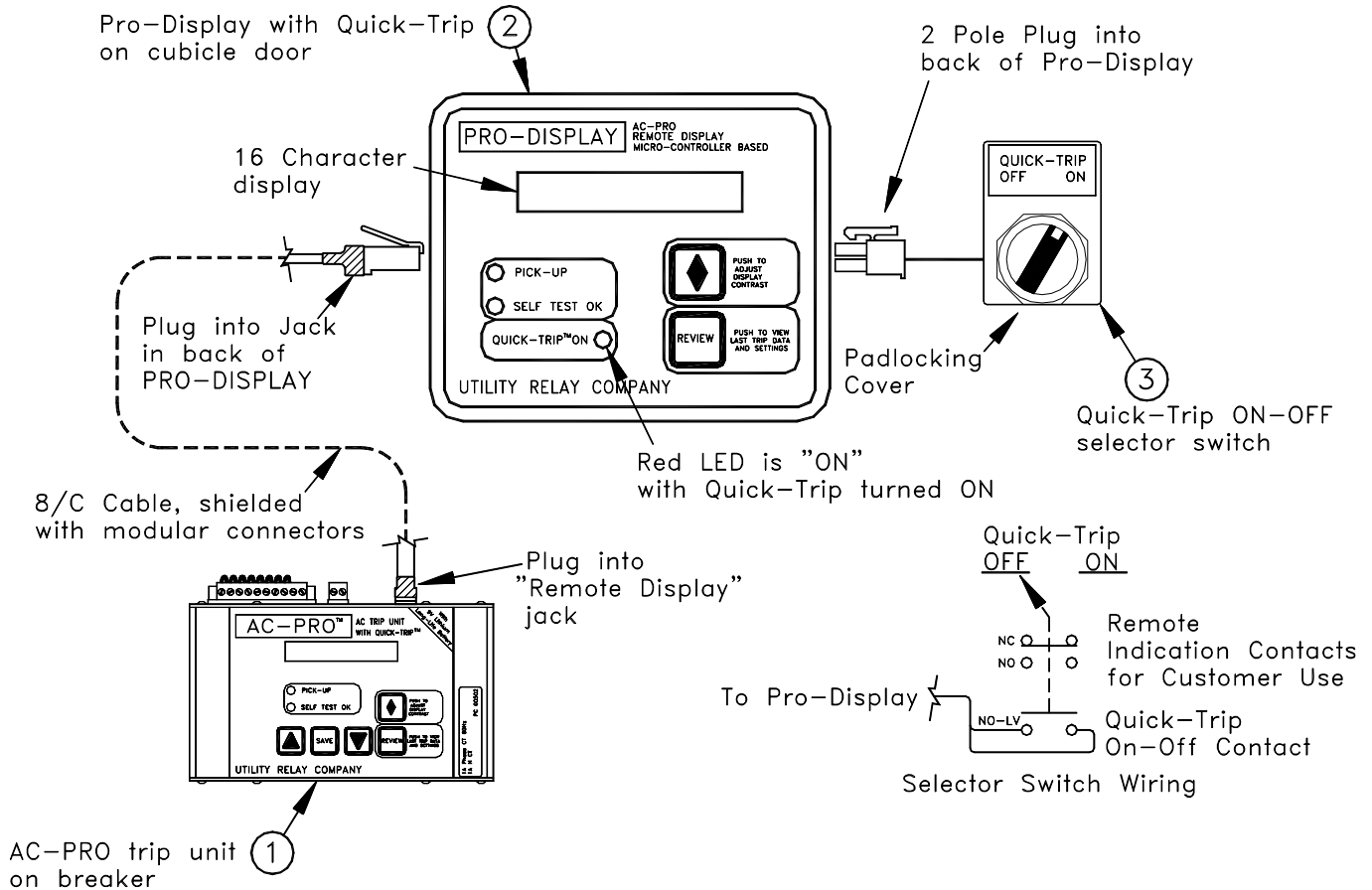

Figure 6.1
QUICK-TRIP™ Connections

6.1 Quick-Trip™ Basics

The QUICK-TRIP system is a manually controlled Zone Selective Interlock (ZSI) system. It can reduce trip times when turned on and allows selective coordination between circuit breakers when turned off.

If maintenance personnel must work on energized equipment, they will first turn the QUICK-TRIP system on at the breaker feeding the equipment. If a fault now occurs, the upstream breaker will trip quickly based on the QUICK-TRIP settings **reducing the Arc Flash Hazard to personnel**.

When the work is done, the QUICK-TRIP system is turned off and the original selective coordination is back in effect.

The QUICK-TRIP system consists of the following components:

1. AC-PRO trip unit with QUICK-TRIP.
2. Pro-Display with a "QUICK-TRIP ON" LED.
3. Padlocking selector switch mounted near the Pro-Display that is used to turn QUICK-TRIP on and off.

When QUICK-TRIP is **on**, the following settings are enabled:

- GF QUICK-TRIP (GF QT)
- I QUICK-TRIP (I QT)

All other settings remain in effect.

The "QUICK-TRIP ON LED" provides positive indication that the QUICK-TRIP settings are active if the LED is on.

The extra contact block on the QUICK-TRIP selector switch can be used for local or remote indication of the QUICK-TRIP selector switch setting.

**** IMPORTANT ****

A qualified engineer must determine the QUICK-TRIP settings, calculate the incident energy levels and determine the Hazard Risk Categories (HRC).

If an older Pro-Display **without** the "QUICK-TRIP ON" LED is plugged into an AC-PRO with QUICK-TRIP, the QUICK-TRIP settings will always be **on**.

Drill 1 11/16" diameter hole
or alternately use
1 1/4" conduit knockout punch

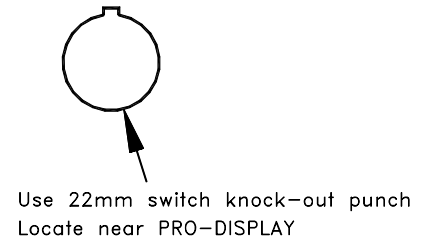
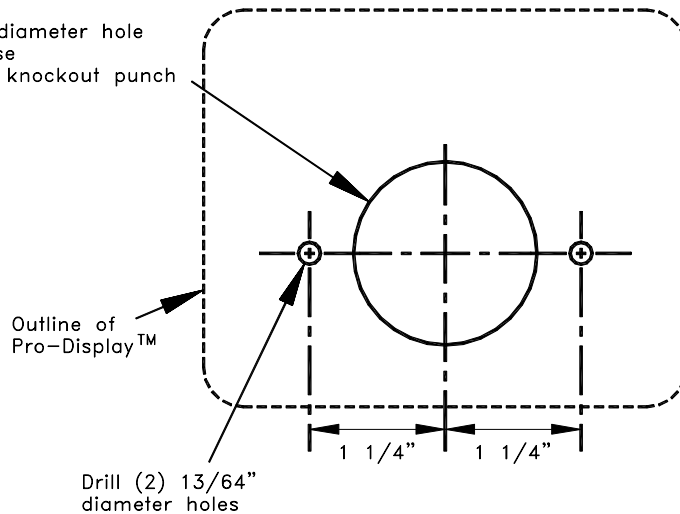

Figure 6.2
QUICK-TRIP™ Drilling Plan

6.2 Quick-Trip™ Installation

The QUICK-TRIP system is easy to install on the front of the breaker cubicle door.

To install the Pro-Display:

1. Find a suitable location on the cubicle door and mark the location of the three (3) holes using the dimensions in Figure 6.2.
2. Drill two (2) 13/64" mounting holes.
3. For the center hole, cut a 1-11/16" diameter hole using a hole saw or alternately, use a 1-1/4" conduit knockout punch.

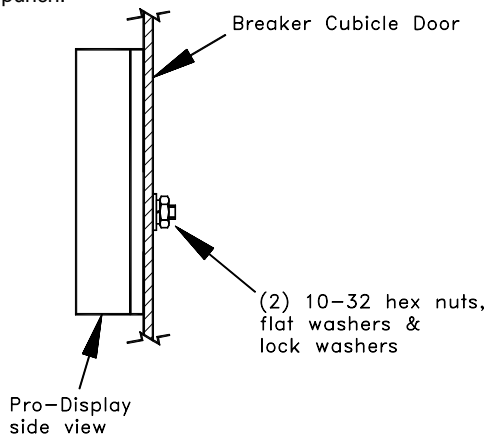

Figure 6.3
Pro-Display Mounting

4. Attach the Pro-Display to the front of the cubicle door using two (2) 10-32 hex nuts, flat washers and lock washers.
5. Connect the Pro-Display to the AC-PRO trip unit by plugging one end of the shielded modular cable provided into the jack on the back of the Pro-Display. Plug the other end of the cable into the "Remote Display" jack on the top of the AC-PRO.
6. Route the cable so it does not interfere with the opening or closing of the cubical door or with the racking of the breaker between connect and disconnect positions. Use cable ties and holders to hold the cable in position.

To install the on/off selector switch:

1. Use a 22mm switch knock-out punch to make a hole in the cubicle door for the selector switch. The selector switch should be located near the remote display.
2. Attach the selector switch, padlock attachment and contact blocks to the cubicle door.
3. Plug the cable from the switch into the back of the Pro-Display.

6.3 Quick-Trip™ & Pro-Display Operation

The Pro-Display will display the same messages as the display on the AC-PRO. It provides the capability of viewing the breaker currents and reviewing the settings and the last trip data *without opening the breaker cubicle door.*

For security reasons, it is not possible to change any settings from the Pro-Display.

When the display on the Pro-Display is **off**, push the "REVIEW" button to power the Pro-Display from the internal battery in the AC-PRO. The following information will be available:

- Last trip data including the type of trip and the currents
- Pushing the "REVIEW" button will display the trip log
- Continuing to push the "REVIEW" button will step through the settings
- The "SELF TEST OK" LED will indicate proper operation
- The "QUICK-TRIP ON" LED will indicate the on/off status of the QUICK-TRIP settings

When the display on the Pro-Display is **on**, the phase currents will be displayed (if greater than 10% of the CT tap). The following information will also be available:

- The "PICK-UP" LED will indicate if phase currents are above the Long Time pick-up setting
- The "SELF TEST OK" LED will indicate proper operation
- The "QUICK-TRIP ON" LED will indicate the on/off status of the QUICK-TRIP settings

Pushing the "REVIEW" button will display:

- Last trip data including the type of trip and the currents
- Pushing the "REVIEW" button will display the trip log
- Continuing to push the "REVIEW" button will step through the settings

7.0 Commissioning the AC-PRO™

Before the AC-PRO trip unit is put into service, it must first be commissioned so it will function. This requires the user to enter all of the pick-up and delay settings into the unit.

The commissioning process normally takes less than a few minutes to complete.

****** IMPORTANT ******

The trip unit will NOT FUNCTION as it is shipped from the factory. The user must first COMMISSION the unit as outlined in this Section to make it functional.

After the AC-PRO is installed on the breaker, it must be commissioned as follows:

- 1) Connect the security key (see Section 4.2)
- 2) Push the "REVIEW" push button to power-up the trip unit. The trip unit will alternately display the following:

ENTER DATA

SERIAL # XXXXXXX

Press the "SAVE" push button. The following will be displayed:

PROD: H4.70F5.10

Press the "SAVE" push button to begin the commissioning process.

- 3) Enter the appropriate CT tap, pick-up and delay settings using the "UP", "DOWN" and "SAVE" push buttons.

- 4) Remove the security key (see Section 4.2).

Sections 7.1 through 7.20 go over the commissioning process in greater detail.

******NOTE******

An additional security feature is provided to avoid accidentally changing the CT tap setting. See Section 7.3.

7.1 Powering-Up the Trip Unit

In normal service, the AC-PRO trip unit is powered directly from the breaker mounted CTs.

For commissioning, the AC-PRO trip unit can be powered-up in either of the following two ways.

1) Internal Battery

Press the "REVIEW" button to power-up the trip unit using the internal battery.

The trip unit is designed to shut off automatically if none of the 4 lower push buttons on the face of the unit are pressed for 30 seconds. It is best to have all the desired settings readily available before commissioning the unit when using the battery.

If the unit shuts down before the commissioning process is completed, the process must be started again from the beginning.

2) External Power

Apply 24 VAC to the "auxiliary power" jack located on the top of the trip unit using the Utility Relay auxiliary power pack. (Utility Relay Company part number T-390).

By applying external power, the unit will stay energized as long as necessary to complete the commissioning process.

7.2 Security Key

The following will be displayed if the security key is not already connected:

SECURITY KEY OFF

Connect the security key to continue the commissioning process (See Section 4.2).

7.3 CT Rating

After the security key is connected, the following will be displayed:

CT RATING XXXXA

Where "XXXX" represents the CT rating in amps. The CT rating can range from 50 amps to 5,000 amps in 25 amp steps and 5250 amps to 6000 amps in 250 amp steps.

The CT rating entered into the trip unit **must** correspond to the actual rating of the phase and neutral CT tap that the trip unit is connected to.

A security feature is provided so the CT rating will not be accidentally changed later.

The **CT security feature** must be used to enter the initial CT rating or to change the CT rating.

To Activate the CT Security Feature

In the commissioning mode and when the CT rating is displayed:

Simultaneously push and release **both** the "SAVE" and "REVIEW" push buttons

This allows the CT rating to be changed.

With the security feature activated, press and hold the "UP" or "DOWN" push button as required until the correct CT rating is displayed.

Press the "SAVE" push button to continue.

7.4 Long Time (LT) Pick-Up Setting

The following will be displayed:

LT PICK-UP XXXXA

Where "XXXX" represents the LT Pick-Up setting in amps. The LT Pick-Up setting ranges from 20% to 100% of the CT rating. This setting is adjustable in 5 amp steps (50 amp steps for 5250 to 6000 amp CTs and 0.5 amp steps for 50 to 200 amp CTs).

Press and hold the "UP" or "DOWN" push button as required until the correct LT Pick-Up setting is displayed.

Press the "SAVE" push button to continue.

7.5 Long Time (LT) Delay Setting

The following will be displayed:

LT DELAY XX.XS

Where "XX.X" represents the LT Delay band. The LT Delay band is labeled by the number of seconds to trip at **6 times** the LT Pick-Up setting.

The LT Delay setting ranges from 2.0 to 30.0 seconds in steps of 0.5 seconds. This provides 57 LT Delay bands.

Please note that the LT trip time is not a constant value, but is a function of breaker current. For lower currents the trip time is longer, and for higher currents the trip time is shorter. The trip time is only equal to the LT Delay setting when a

current 6 times the LT Pick-Up setting is applied. See the time-current curves in Figure 17.2.

Press and hold the "UP" or "DOWN" push button as required until the correct LT Delay setting is displayed.

Press the "SAVE" push button to continue.

7.6 Short Time (ST) Pick-Up Setting

The following will be displayed:

ST PICK-UP OFF

If the ST function is **not** desired, press the "SAVE" push button and go to Step 7.9.

If the ST function **is** desired, press the "UP" push button and the following will be displayed:

ST PICK-UP XXXXA

Where "XXXX" represents the ST Pick-Up in amps.

The ST Pick-Up setting ranges from 150% to 1200% of the LT Pick-Up setting in 100 amp steps (1000 amp steps for 5250 to 6000 amp CTs and 10 amp steps for 50 to 200 amp CTs). Press and hold the "UP" or "DOWN" push button as required until the correct ST Pick-Up setting is displayed.

Press the "SAVE" push button to continue.

7.7 Short Time (ST) Delay Setting

If the ST function is not off, then the following will be displayed:

ST DELAY .XXS

Where ".XX" represents the ST Delay.

The ST Delay settings are .07, .10, .15, .20, .30 and .40 seconds.

Press and hold the "UP" or "DOWN" push button as required until the correct ST Delay setting is displayed.

Press the "SAVE" push button to continue.

7.8 Short Time (ST) I²T

The I²T function adds a ramp to the ST delay if required for coordination purposes as shown in the Overload TCC in Figure 17.2.

If the ST function is not off, then the following will be displayed:

ST I²T XXX

Where "XXX" represents ON or OFF.

If the ST I²T ramp **is** desired, press the "UP" push button. If the ST I²T ramp **is not** desired, press the "DOWN" push button.

Press the "SAVE" push button to continue.

7.9 Instantaneous (I) Pick-Up Setting

The following will be displayed:

I PICK-UP XXXXXA

Where "XXXXX" represents the I Pick-Up in amps.

The I Pick-Up setting ranges from 150% to 1200% of the LT Pick-Up setting in 100 amp steps (1000 amp steps for 5250 to 6000 amp CTs and 10 amp steps for 50 to 200 amp CTs).

Press and hold the "UP" or "DOWN" push button as required until the correct I Pick-Up setting is displayed.

If the I function is **not** desired and the ST function is **not** off, press the "DOWN" push button until the following is displayed:

I PICK-UP OFF

**** NOTE ****

The trip unit does not allow setting both the ST and the I functions off at the same time.

Press the "SAVE" push button to continue.

7.10 Ground Fault (GF) Pick-Up Setting

If the GF function is **not** desired, then press the "DOWN" push button until the following is displayed:

GF PICK-UP OFF

If the GF function **is** desired, press the "UP" push button and the following will be displayed:

GF PICK-UP XXXXA

Where "XXXX" represents the GF Pick-Up setting in amps.

The minimum GF Pick-Up setting is 20% of the CT rating with 10 amp steps (1 amp steps for 50 to 200 amp CTs). The maximum value is 200% of the CT rating or 1200 amps, whatever is lower.

Press and hold the "UP" or "DOWN" push button as required until the correct GF Pick-Up setting is displayed.

Press the "SAVE" push button to continue.

7.11 Ground Fault (GF) Delay Setting

If the GF function is not off, then the following will be displayed:

GF DELAY .XXS

Where ".XX" represents the GF Delay.

The GF Delay settings are .10, .20, .30, .40 and .50 seconds.

Press and hold the "UP" or "DOWN" push button as required until the correct GF Delay setting is displayed.

Press the "SAVE" push button to continue.

7.12 Ground Fault (GF) I²T

The I²T function adds a ramp to the GF delay if required for coordination purposes as shown in the Ground Fault TCC in Figure 17.3.

If the GF function is not off, then the following will be displayed:

GF I SQ T XXX

Where "XXX" represents ON or OFF.

If the GF I²T ramp **is** desired, press the "UP" push button. If the GF I²T ramp **is not** desired, press the "DOWN" push button.

Press the "SAVE" push button to continue.

**** NOTE ****

On a 4-wire system, a neutral CT must be installed to avoid nuisance GF trips.

7.13 Phase Unbalance (U/B) Pick-Up

The following will be displayed:

U/B PICK-UP OFF

If the U/B function is **not** desired, then press the "SAVE" push button and go to Step 7.15.

If the U/B function **is** desired, press the "UP" push button and the following will be displayed:

UB PICK-UP XX%

Where "XX" represents the U/B Pick-Up setting in percentage. The minimum and maximum UB Pick-Up setting is 20% and 50% in steps of 5 percentage points.

Press and hold the "UP" or "DOWN" push button as required until the correct U/B Pick-Up setting is displayed.

Press the "SAVE" push button to continue.

**** NOTE ****

The U/B function should not be confused with the GF function. The U/B function is a motor protection function and should **ONLY** be used on breakers feeding a large 3-phase motor where currents are normally balanced.

7.14 Phase Unbalance (U/B) Delay

If the U/B function is not off, then the following will be displayed:

UB DELAY XXS

Where "XX" represents the U/B Delay. The U/B Delay setting ranges from 1 to 60 seconds in steps of 1 second.

Press and hold the "UP" or "DOWN" push button as required until the correct U/B Delay setting is displayed.

Press the "SAVE" push button to continue.

7.15 Address

This setting applies only to AC-PRO+ trip units with the communication option and will not be displayed on non-communicating trip units.

Each communicating trip unit that shares the same twisted pair must have a unique address.

ADDRESS XXX

Where "XXX" represents the trip unit address and ranges from 1 to 127 in increments of 1. Press the "UP" or "DOWN" push button as required until the desired address setting is displayed.

Press the "SAVE" push button to continue.

NOTE: Two trip units can have the same address as long as they are not connected to the PC, Ethernet converter, RS-232 converter or Local Communications Interface via the same twisted pair cable.

7.16 Reply Delay

This setting applies only to AC-PRO+ trip units with the communication option and will not be displayed on non-communicating trip units.

The reply delay setpoint is the minimum delay between the trip unit's receipt of a MODBUS packet and its reply.

The reply delay can be either 5 or 10 milliseconds. The factory default is 5 milliseconds.

REPLY DELAY XXMS

Where "XXMS" represents either 5 or 10 milliseconds. Press the "UP" or "DOWN" push button as required until the desired delay setting is displayed.

Press the "SAVE" push button to continue.

7.17 Quick-Trip™ Ground Fault (QT GF)

This setting applies only if the QUICK-TRIP Pro-Display and selector switch are installed. See Section 6.0 for details.

If the QT GF function is **not** desired, then press the "DOWN" push button until the following is displayed:

GF QT PICK-UP OFF

If the QT GF function **is** desired, press the "UP" push button and the following will be displayed:

GF QT PICK-UP XXXXA

Where "XXXX" represents the QT GF Pick-Up setting in amps.

The minimum QT GF Pick-Up setting is 20% of the CT rating with 10 amp steps (1 amp steps for 50 to 200 amp CTs). The maximum value is 200% of the CT rating or 1200 amps, whatever is lower.

Press and hold the "UP" or "DOWN" push button as required until the correct QT GF Pick-Up setting is displayed.

The QT GF function has a non-adjustable short delay time as shown in Figure 17.4.

Press the "SAVE" push button to continue.

7.18 Quick-Trip™ Instantaneous (QT I)

This setting applies only if the QUICK-TRIP Pro-Display and selector switch are installed. See Section 6.0 for details.

The following will be displayed:

I QT PICK-UP XXXXXA

Where "XXXXX" represents the QT I Pick-Up in amps.

The QT I Pick-Up setting ranges from 150% to 1200% of the LT Pick-Up setting in 100 amp steps (1000 amp steps for 5250 to 6000 amp CTs and 10 amp steps for 50 to 200 amp CTs).

Press and hold the "UP" or "DOWN" push button as required until the correct QT I Pick-Up setting is displayed.

The QT I function does not have an off setting. It is turned on or off using the QUICK-TRIP ON-OFF selector switch. If the Pro-Display with QUICK-TRIP is not installed, then this function is always off.

Press the "SAVE" push button to continue.

7.19 Thermal Memory

The AC-PRO trip unit has a Thermal Memory feature for the following protective functions:

- Long Time (LT)
- Short Time (ST)
- Ground Fault (GF)

Thermal Memory can be turned on or off for the LT and ST protective functions only.

Thermal Memory for the GF function is always on and cannot be turned off. The GF Thermal Memory feature provides protection against "sputtering" ground faults.

Except for unusual conditions, it is recommended that the Thermal Memory feature for LT and ST should be turned on.

Cycling overloads that are not above the LT Pick-Up long enough to cause a trip can still lead to thermal damage to wiring and equipment. With Thermal Memory turned on a cycling overload can still produce a LT trip to protect cables and equipment even if any individual overload event did not persist long enough to directly cause a LT trip.

With Thermal Memory turned off, an overload that drops below the LT Pick-Up will reset the LT trip register. If the current goes above the LT Pick-Up again, the LT trip register starts from zero.

The above is also true for the ST function.

The following will be displayed:

THERMAL MEM XXX

Where "XXX" represents Thermal Memory ON or OFF for the LT and ST functions.

If Thermal Memory for LT and ST is desired, press the "UP" push button. If Thermal Memory for LT and ST is not desired, press the "DOWN" push button. Thermal Memory for LT and ST can not be individually turned on or off.

Press the "SAVE" push button to continue.

7.20 Exit Procedure

The following will be displayed:

SAVE IF DONE

REVIEW TO REVIEW

If it is desired to review the setting, push the "REVIEW" push button. Make any changes necessary using the "UP" or "DOWN" push buttons. As before, use the "SAVE" push button to move to each new setting.

If the settings are as desired, push the "SAVE" push button.

The following will be displayed:

REMOVE KEY TO

COMMISSION UNIT

Remove the "key" (See section 4.2). The settings will be saved in the non-volatile EEPROM memory.

If the commissioning process was performed using the internal battery, the unit will turn itself off.

If external power was used to power the trip unit during the commissioning process, the following will be displayed:

LOW CURRENT

The commissioning process is complete.

8.0 Changing Settings

**** IMPORTANT ****

While it is possible to make changes to the settings with the breaker in service, it is strongly recommended that **the breaker must be removed from service** while making these changes since the breaker is energized and the trip unit will not provide protection during a small part of this process.

After the trip unit is commissioned, settings can easily be changed in the following manner.

Connect the security key. See Section 4.2.

Power up the trip unit by pressing "REVIEW" or by applying external power as described in Section 7.1.

Press the "REVIEW" push button. The following will be displayed:

ENTER DATA

SERIAL # XXXXXXXX

Press the "SAVE" push button.

Make any necessary changes using the "UP" or "DOWN" push buttons. Use the "SAVE" push button to move to each new setting.

**** IMPORTANT ****

The CT rating entered in the trip unit must match the rating of the CT the trip unit is connected to.

A security feature protects against accidentally changing the CT rating. See Section 7.3.

After going through all the settings, the following will be displayed.

SAVE IF DONE

REVIEW TO REVIEW

If it is desired to review the setting, push the "REVIEW" push button. Make any changes necessary using the "UP" or "DOWN" push buttons. As before, use the "SAVE" push button to move to each new setting.

If the settings are as desired, push the "SAVE" push button. The following will be displayed:

REMOVE KEY TO

COMMISSION UNIT

Remove the security key (See Section 4.2). The settings will be saved in the non-volatile EEPROM memory.

The Settings have been changed.

Remember, if the trip unit loses power during this process, the old settings will be retained and the process must be repeated.

9.0 Last Trip Data Recall

The AC-PRO has an especially useful last trip data recall and trip counter feature.

After a breaker trip, the trip unit will be able to display the type of trip (i.e. LT, ST, I, GF, U/B, GF QT or I QT as applicable) along with the currents at the time of trip. This information is saved in the non-volatile FLASH memory and is available immediately after a trip or anytime thereafter.

**** NOTE ****

Only the complete data from the last trip is saved. The second time the breaker trips, the new trip data is written over the first trip data. The trip counter is also updated at this time.

Push the "Review" push button to recall the Last Trip Data and settings. The following will be displayed if there was **no** last trip:

NO LAST TRIP

If there was a last trip, the following messages will alternately display showing the cause of the trip and the currents at the time of trip. The messages alternate at a one second interval rate:

LAST TRIP	XXXX
PHASE A	XXXXXXA
PHASE B	XXXXXXA
PHASE C	XXXXXXA
GF	XXXXXXA

If GF current is greater than 2 times the CT Rating, the following will be displayed for GF:

GF>2XCT RATING

Only those phase currents greater than 10% of the CT Rating will be displayed.

U/B YY%

The U/B percentage will be displayed if on and the U/B is greater than 4%.

The text "XXXX" is the type of tripping event (i.e. LT, ST, I, GF, U/B, GF QT or I QT as applicable) and "XXXXX" is the magnitude of the current at the time of trip for each phase. The text "YY" is the percentage of unbalance at trip.

Press the "REVIEW" push button again to view the following message:

HOLD <REVIEW> TO
VIEW TRIP COUNTS

If the "REVIEW" button is pushed again and held down for longer than 2 seconds, each type of trip is displayed along with the number of times that trip has occurred. If the "REVIEW" button is pressed, but not held for 2 seconds, the trip count is skipped and the settings are displayed.

INST TRIPS: XX

Push the "REVIEW" Button.

LT TRIPS: XX

Push the "REVIEW" Button.

ST TRIPS: XX

Push the "REVIEW" Button.

GF TRIPS: XX

Push the "REVIEW" Button.

U/B TRIPS: XX

Push the "REVIEW" Button.

GF QT TRIPS: XX

Push the "REVIEW" Button.

I QT TRIPS: XX

The text "XX" is the number of trips since last commissioned or reset.

By pressing the "REVIEW" push button the present settings programmed in the trip unit can be stepped through in sequence.

**** NOTE ****

Pushing the "SAVE", "UP" or "DOWN" push buttons during last trip data recall has no effect because the key is not installed.

When pushing "REVIEW" after the last setting, the trip unit will turn it self off.

If the "REVIEW" push button is not pressed for about 30 seconds, the trip unit will also turn off.

10.0 Normal Operations

Breaker Current Less than about 8% of CT Rating:

With all phase currents less than about 8%, the trip unit is not receiving enough energy from the CTs to operate and the display will be blank (Except for the communication version with a PT module).

Breaker Current Less than 12.5% of CT Rating:

When the currents are greater than about 8% but less than about 12.5% of the CT rating, the display will show the following:

LOW CURRENT

Breaker Current Greater than 12.5% of CT Rating:

If the breaker current is greater than about 12.5% of the CT rating but less than the LT pick-up value, the following will be alternately displayed on the LCD at one second intervals:

PHASE A XXXXA

PHASE B XXXXA

PHASE C XXXXA

GF XXXXA

Where "XXXX" is the current in amps for that phase or ground fault current.

Only those currents above 12.5% will be displayed. The GF current will only be displayed if the GF function is on.

Breaker Current Greater than the LT pick-up:

When the trip unit detects a phase overload situation, the "PICK-UP" LED on the front of the trip unit will go on, and the following will alternately be displayed on the LCD at one second intervals:

OVERLOAD

PHASE A XXXXA

PHASE B XXXXA

PHASE C XXXXA

GF XXXXA

Where "XXXX" is the current in amps for that phase or ground fault current.

Only those currents above 12.5% will be displayed. The GF current will only be displayed if the GF function or QT GF function is on.

11.0 Testing

A "primary injection" test is recommended as the final test of the AC-PRO retrofit.

It is not necessary to turn off the Unbalance (U/B) function when doing a single-phase primary injection test.

If used, GF must be temporarily turned off when testing the other trip functions.

11.1 Commission the Trip Unit

Before proceeding with the normal primary injection tests, the trip unit must be commissioned to make it functional. See Section 7.0 for the commissioning procedure.

It is best to use the final pick-up and time delay settings if they are known. If not, use typical settings for the primary injection test.

Make sure GF is temporarily turned off. The U/B function can be left on if desired.

11.2 LT Trip Test

Make sure GF is temporarily turned off. The U/B function can be left on.

To test the LT Pick-Up, increase the current until the "Pick-Up" LED illuminates.

The injected current should correspond to the programmed LT Pick-Up setting. Verify that the correct phase is indicated on the LCD display.

To test the LT trip time, first calculate the trip time based on the value of the test current that will be applied. Use the formula in Section 15.1 or the chart in Section 12.3..

**** NOTE ****

A simple shortcut is to note that the trip time (center of the curve) at 3 times the LT pick-up current is 4 times the LT Delay setting.

For example:

If LT Pick-Up is 1600A and Delay is 10.0S, then the trip time at 4800A (3 times 1600A) is 40 sec. (4 times 10 sec).

11.3 ST Trip Test

Make sure GF is temporarily turned off. The U/B function can be left on.

To test the ST Pick-Up, temporarily set ST I²T off and apply a short pulse of current that is 10% or 20% less than the ST Pick-Up setting. Continue applying short pulses of current while increasing the current for each pulse until a ST trip occurs. The first current where a ST trip occurred is the ST Pick-Up.

To test the ST Delay, turn ST I²T on again (if applicable) and apply a current that is at least 10% greater than the ST Pick-Up current.

The trip time should fall within the time band shown on the Time-Current curves.

11.4 I Trip Test

Make sure GF is temporarily turned off. The U/B function can be left on.

Test the Instantaneous Pick-Up and trip time in the same manner as ST in Section 11.3.

11.5 GF Trip Test

With GF Pick-Up and Delay set to the required values, testing any one of the three poles will provide a GF trip.

Test the GF Pick-Up and trip time in the same manner as ST in Section 11.3.

11.6 QT GF Trip Test

To test QT GF the Pro-Display with QUICK-TRIP must be connected to the AC-PRO trip unit and the QUICK-TRIP ON-OFF selector switch must also be connected as shown in Figure 6.1.

With QT GF Pick-Up set to the required value and the QUICK-TRIP selector switch turned to the on position, testing any one of the three poles will provide a QT GF trip.

Test the QT GF Pick-Up and trip time in the same manner as the normal GF function.

11.7 CT Phasing Test for GF

The breaker CT phasing is only important for the GF function and the QT GF function. If one of the breaker mounted CTs has reversed polarity, a nuisance GF or QT GF trip will most likely occur. **With the breaker in service on a 3-phase system, the last trip data with a reversed polarity CT will show the GF current as approximately two times the phase currents.**

Since primary injection testing normally tests only one phase at a time, a breaker CT with reversed polarity will not be detected with the normal tests. By using the following method, a primary injection test set can be used to test for proper CT polarity.

Figures 11.1 and 11.2 show a method to verify that the breaker CT polarities match. The setup in Figure 11.1 verifies that the CT polarities of Phase A and Phase B match. The setup in Figure 11.2 verifies that the CT polarities of Phase B and Phase C match.

It is only necessary to inject a current slightly greater than the GF Pick-Up setting and to verify that a GF trip does not occur.

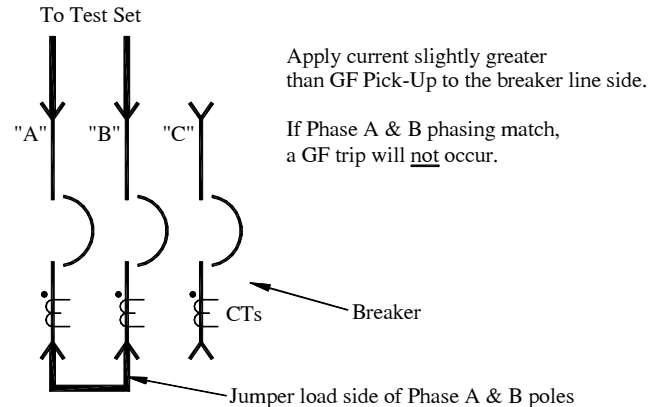

Figure 11.1 Phase A & B, CT Phasing Test

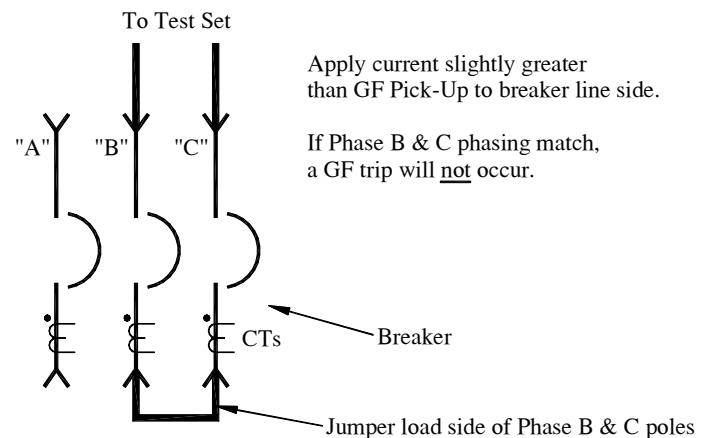

Figure 11.2 Phase B & C, CT Phasing Test

If a GF trip does occur, determine which CT has the reversed polarity. Reverse the secondary connections at the CT to correct the reversed polarity.

The breakers shown in Figures 11.1 & 11.2 have the CTs on the load side. Use exactly the same method if the CTs are on the breaker line side or if they are staggered.

If a neutral CT is used, its polarity must match the polarity of the breaker mounted CTs. Testing for proper neutral CT polarity is more difficult because it is mounted remote from the breaker.

11.8 QT I Trip Test

To test QT I the Pro-Display with QUICK-TRIP must be connected to the AC-PRO trip unit and the QUICK-TRIP ON-OFF selector switch must also be connected as shown in Figure 6.1.

With QT I Pick-Up set to the required value and the QUICK-TRIP selector switch turned to the on position, test all three breaker poles in the same manner as the normal I function.

11.9 U/B Trip Test

The U/B trip function is not easy to test with a single phase, high current test set.

Figure 11.3 illustrates a method to test the U/B trip function. It requires using cable or bus to jumper the breaker poles as shown. This generates an unbalanced current of 50% or slightly more depending on how equally the current is split between the two poles.

It is only necessary to inject a current equal to 20% or 30% of the CT rating for this test. It is only possible to test the U/B trip time and not the U/B Pick-Up with this method.

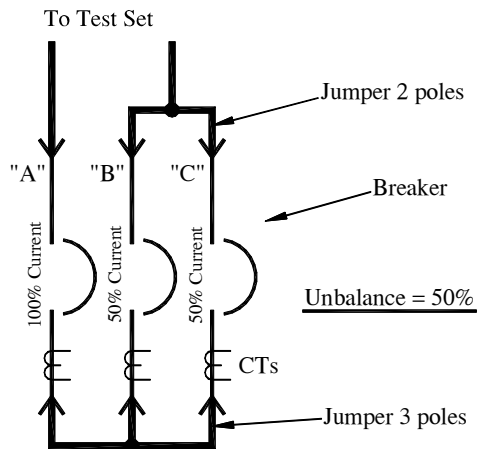

Figure 11.3 U/B Test

11.10 Erase Last Trip Data

After completing the primary or secondary injection tests, it is important to erase the last trip data from the memory of the trip unit.

**** IMPORTANT ****

Erase the last trip data from the memory of the trip unit after completing the primary or secondary injection tests.

To erase the memory in the trip unit after completing the primary or secondary injection tests, use the following method:

- 1) The trip unit can be either off or powered-up.
- 2) Push the "REVIEW" button to display the last trip data.
- 3) While the last trip data is flashing, push and hold both the "UP" and "DOWN" push buttons.
- 4) Continue to hold the "UP" and "DOWN" buttons and push the "SAVE" button. Release all buttons. The following will be displayed:

NO LAST TRIP

**** IMPORTANT ****

If the last trip data is not erased after the primary or secondary injection test, the operating personnel may later assume that the breaker interrupted a fault at some time in the past when they recall the last trip data. The trip counter will also have misleading data.

12.3 LT Delay Testing Chart

This chart provides trip times in Seconds for the LT Delay settings at 3.0X, 4.0X and 6.0X where "X" is in multiples of the LT Pick-Up setting.

The Maximum, Minimum and Nominal trip times are given for each LT Delay setting and the three listed test currents.

The Time-Current Curves in Figure 17.2 along with the equations in Section 15.1 can be used to determine the trip times of the other trip functions.

A test chart with additional LT Delay test points is available at www.utilityrelay.com.

LT Delay Setting	Trip Time Range	Test Current		
		3.0X	4.0X	6.0X
2.0	Max	9.88	5.56	2.47
	Nominal	8.00	4.50	2.00
	Min	6.61	3.72	1.65
2.5	Max	12.35	6.94	3.09
	Nominal	10.00	5.63	2.50
	Min	8.26	4.65	2.07
3.0	Max	14.81	8.33	3.70
	Nominal	12.00	6.75	3.00
	Min	9.92	5.58	2.48
3.5	Max	17.28	9.72	4.32
	Nominal	14.00	7.88	3.50
	Min	11.57	6.51	2.89
4.0	Max	19.75	11.11	4.94
	Nominal	16.00	9.00	4.00
	Min	13.22	7.44	3.31
4.5	Max	22.22	12.50	5.56
	Nominal	18.00	10.13	4.50
	Min	14.88	8.37	3.72
5.0	Max	24.69	13.89	6.17
	Nominal	20.00	11.25	5.00
	Min	16.53	9.30	4.13
5.5	Max	27.16	15.28	6.79
	Nominal	22.00	12.38	5.50
	Min	18.18	10.23	4.55
6.0	Max	29.63	16.67	7.41
	Nominal	24.00	13.50	6.00
	Min	19.83	11.16	4.96
6.5	Max	32.10	18.06	8.02
	Nominal	26.00	14.63	6.50
	Min	21.49	12.09	5.37
7.0	Max	34.57	19.44	8.64
	Nominal	28.00	15.75	7.00
	Min	23.14	13.02	5.79
7.5	Max	37.04	20.83	9.26
	Nominal	30.00	16.88	7.50
	Min	24.79	13.95	6.20
8.0	Max	39.51	22.22	9.88
	Nominal	32.00	18.00	8.00
	Min	26.45	14.88	6.61
8.5	Max	41.98	23.61	10.49
	Nominal	34.00	19.13	8.50
	Min	28.10	15.81	7.02
9.0	Max	44.44	25.00	11.11
	Nominal	36.00	20.25	9.00
	Min	29.75	16.74	7.44
9.5	Max	46.91	26.39	11.73
	Nominal	38.00	21.38	9.50
	Min	31.40	17.67	7.85
10.0	Max	49.38	27.78	12.35
	Nominal	40.00	22.50	10.00
	Min	33.06	18.60	8.26
10.5	Max	51.85	29.17	12.96
	Nominal	42.00	23.63	10.50
	Min	34.71	19.52	8.68
11.0	Max	54.32	30.56	13.58
	Nominal	44.00	24.75	11.00
	Min	36.36	20.45	9.09

LT Delay Setting	Trip Time Range	Test Current		
		3.0X	4.0X	6.0X
11.5	Max	56.79	31.94	14.20
	Nominal	46.00	25.88	11.50
	Min	38.02	21.38	9.50
12.0	Max	59.26	33.33	14.81
	Nominal	48.00	27.00	12.00
	Min	39.67	22.31	9.92
12.5	Max	61.73	34.72	15.43
	Nominal	50.00	28.13	12.50
	Min	41.32	23.24	10.33
13.0	Max	64.20	36.11	16.05
	Nominal	52.00	29.25	13.00
	Min	42.98	24.17	10.74
13.5	Max	66.67	37.50	16.67
	Nominal	54.00	30.38	13.50
	Min	44.63	25.10	11.16
14.0	Max	69.14	38.89	17.28
	Nominal	56.00	31.50	14.00
	Min	46.28	26.03	11.57
14.5	Max	71.60	40.28	17.90
	Nominal	58.00	32.63	14.50
	Min	47.93	26.96	11.98
15.0	Max	74.07	41.67	18.52
	Nominal	60.00	33.75	15.00
	Min	49.59	27.89	12.40
15.5	Max	76.54	43.06	19.14
	Nominal	62.00	34.88	15.50
	Min	51.24	28.82	12.81
16.0	Max	79.01	44.44	19.75
	Nominal	64.00	36.00	16.00
	Min	52.89	29.75	13.22
16.5	Max	81.48	45.83	20.37
	Nominal	66.00	37.13	16.50
	Min	54.55	30.68	13.64
17.0	Max	83.95	47.22	20.99
	Nominal	68.00	38.25	17.00
	Min	56.20	31.61	14.05
17.5	Max	86.42	48.61	21.60
	Nominal	70.00	39.38	17.50
	Min	57.85	32.54	14.46
18.0	Max	88.89	50.00	22.22
	Nominal	72.00	40.50	18.00
	Min	59.50	33.47	14.88
18.5	Max	91.36	51.39	22.84
	Nominal	74.00	41.63	18.50
	Min	61.16	34.40	15.29
19.0	Max	93.83	52.78	23.46
	Nominal	76.00	42.75	19.00
	Min	62.81	35.33	15.70
19.5	Max	96.30	54.17	24.07
	Nominal	78.00	43.88	19.50
	Min	64.46	36.26	16.12
20.0	Max	98.77	55.56	24.69
	Nominal	80.00	45.00	20.00
	Min	66.12	37.19	16.53
20.5	Max	101.23	56.94	25.31
	Nominal	82.00	46.13	20.50
	Min	67.77	38.12	16.94

LT Delay Setting	Trip Time Range	Test Current		
		3.0X	4.0X	6.0X
21.0	Max	103.70	58.33	25.93
	Nominal	84.00	47.25	21.00
	Min	69.42	39.05	17.36
21.5	Max	106.17	59.72	26.54
	Nominal	86.00	48.38	21.50
	Min	71.07	39.98	17.77
22.0	Max	108.64	61.11	27.16
	Nominal	88.00	49.50	22.00
	Min	72.73	40.91	18.18
22.5	Max	111.11	62.50	27.78
	Nominal	90.00	50.63	22.50
	Min	74.38	41.84	18.60
23.0	Max	113.58	63.89	28.40
	Nominal	92.00	51.75	23.00
	Min	76.03	42.77	19.01
23.5	Max	116.05	65.28	29.01
	Nominal	94.00	52.88	23.50
	Min	77.69	43.70	19.42
24.0	Max	118.52	66.67	29.63
	Nominal	96.00	54.00	24.00
	Min	79.34	44.63	19.83
24.5	Max	120.99	68.06	30.25
	Nominal	98.00	55.13	24.50
	Min	80.99	45.56	20.25
25.0	Max	123.46	69.44	30.86
	Nominal	100.00	56.25	25.00
	Min	82.64	46.49	20.66
25.5	Max	125.93	70.83	31.48
	Nominal	102.00	57.38	25.50
	Min	84.30	47.42	21.07
26.0	Max	128.40	72.22	32.10
	Nominal	104.00	58.50	26.00
	Min	85.95	48.35	21.49
26.5	Max	130.86	73.61	32.72
	Nominal	106.00	59.63	26.50
	Min	87.60	49.28	21.90
27.0	Max	133.33	75.00	33.33
	Nominal	108.00	60.75	27.00
	Min	89.26	50.21	22.31
27.5	Max	135.80	76.39	33.95
	Nominal	110.00	61.88	27.50
	Min	90.91	51.14	22.73
28.0	Max	138.27	77.78	34.57
	Nominal	112.00	63.00	28.00
	Min	92.56	52.07	23.14
28.5	Max	140.74	79.17	35.19
	Nominal	114.00	64.13	28.50
	Min	94.21	53.00	23.55
29.0	Max	143.21	80.56	35.80
	Nominal	116.00	65.25	29.00
	Min	95.87	53.93	23.97
29.5	Max	145.68	81.94	36.42
	Nominal	118.00	66.38	29.50
	Min	97.52	54.86	24.38
30.0	Max	148.15	83.33	37.04
	Nominal	120.00	67.50	30.00
	Min	99.17	55.79	24.79

13.0 Ratings

Ambient Temperature:

Trip Unit:
 -4°F (-20°C) to 150°F (65°C)
 LCD Display:
 Standard Temp, Super Twist
 32°F (0°C) to 122°F (50°C)

Humidity:

95% non-condensing

Conformal Coating:

Acrylic conformal coating,
 HumiSeal type 1B15H
 or
 Konform type AR2000

Enclosure:

AC-PRO trip unit:
 Extruded aluminum housing
 Nominal overall dimensions:
 6.76 X 3.84 X 2.28 inches
 172 X 100 X 58 millimeters

Pro-Display:

Conductive Plastic
 Nominal overall dimensions:
 4.45 X 3.66 X 0.94 inches
 112.9 X 92.8 X 23.8 millimeters

Battery:

Ultralife Model U9VL-J
 1200 mAh Lithium/Manganese Dioxide
 Ten-year rated shelf life
 Non-Rechargeable

14.0 Warranty

A conditional 2-year warranty is offered with each AC-PRO trip unit and Pro-Display.

Contact Utility Relay Company for full details.

15.0 Time-Current Curves

The Time-Current curves are shown in Figures 17.2, 17.3 and 17.4.

For all the functions except U/B, the curves are shown on log-log graph with seconds in the vertical direction and current in the horizontal direction.

Overload and fault currents are shown as multiples of the LT pick-up setting. Ground fault current is shown as a percentage of the CT rating.

For I and QT I pick-up settings below 150% of the CT rating, trip unit power-up time must be added to the Instantaneous Time-Current curve (if the trip unit is not already powered up). The allowance for 3-phase time is shown as a dotted line on the upper right hand Time-Current curve in Figure 17.4.

For QT GF pick-up settings below 120% of the CT rating, trip unit power-up time must be added to the QT GF Time-Current curve (if the trip unit is not already powered up). The allowance of 1-phase time is shown as a dotted line in the QT GF Time-Current curve in Figure 17.4.

Tolerances for the Pick-Up bands are ± 10% in the current direction. Tolerance for LT, ST I²T and GF I²T trip times are + 23% and -17% in the time direction.

The curves for the following time bands:

- LT
- ST I²T
- GF I²T

are based on the following equation:

$$I^2T = \text{Constant}$$

Where: I is current in amps

T is time to trip in seconds (center of the band)

The curves for the U/B function are shown on a semi-log graph with seconds in the vertical direction and unbalance in percent in the horizontal direction.

Tolerance for U/B function is given in Section 15.4.

When performing trip-timing tests using a primary injection test set, the trip time at various test currents can be determined by calculation as explained in Sections 15.1, 15.2 and 15.3.

15.1 LT Trip Time

For overload currents, the " $I^2T = \text{Constant}$ " equation can be restated as follows:

$$T = \frac{TBC_{LT}}{X^2}$$

Where: **T** = time to trip in seconds (center of the band)
X = current in multiples of the LT pick-up setting
TBC_{LT} = the LT Time Band Constant
 = 36 X LT time band setting

**** NOTE ****

The LT Time Band Constant (TBC_{LT}) is by definition 36 times the LT Time Band Setting in seconds.

EXAMPLE #1:

CT Rating 1600A
 LT pick-up 1200A
 LT time band 20.0S
 Overload Current 3600A

$$\begin{aligned} TBC_{LT} &= 36 \times \text{LT Time Band Setting} \\ &= 36 \times 20.0 \\ &= 720 \end{aligned}$$

$$\text{and } X = \frac{\text{overload current}}{\text{LT Pick-Up}} = \frac{3600A}{1200A} = 3$$

therefore:

$$\begin{aligned} \text{trip time} = T &= \frac{TBC_{LT}}{X^2} \text{ or } \frac{720}{3^2} = \frac{720}{9} \\ &= 80 \text{ seconds} \end{aligned}$$

**** IN SUMMARY ****

To calculate the LT trip time:

1) Calculate the LT Time Band Constant (TBC_{LT})

2) Calculate "X" where

$$X = \frac{\text{overload current}}{\text{LT Pick-Up Setting}}$$

3) Solve the equation:

$$\text{trip time(sec)} = \frac{TBC_{LT}}{X^2}$$

15.2 ST Trip Time

With I²T off or for currents greater than 10 X LT Pick-Up Setting, the ST trip time is a constant equal to the ST Time Band setting.

With I²T on and for currents less than 10 X LT Pick-Up Setting, the ST trip time is determined by the following equation:

$$T = \frac{TBC_{ST}}{X^2}$$

Where: **T** = time to trip in seconds (center of the band)
X = current in multiples of the LT pick-up
TBC_{ST} = the ST Time Band Constant

**** NOTE ****

The ST Time Band Constant (TBC_{ST}) =
 40 for the .40S Time Band
 30 for the .30S Time Band
 20 for the .20S Time Band
 15 for the .15S Time Band
 10 for the .10S Time Band
 7 for the .07S Time Band

EXAMPLE #2:

CT Rating 1600A
 LT pick-up 1200A
 ST pick-up 6000A
 ST time band .20S I²T ON
 Overload Current 7200A

$$TBC_{ST} = 20$$

$$\text{and } X = \frac{\text{overload current}}{\text{LT Pick-Up}} = \frac{7200A}{1200A} = 6$$

therefore:

$$\begin{aligned} \text{trip time} = T &= \frac{TBC_{ST}}{X^2} \text{ or } \frac{20}{6^2} = \frac{20}{36} \\ &= .556 \text{ seconds} \end{aligned}$$

**** IN SUMMARY ****

To calculate the ST I²T trip time:

1) Determine the ST Time Band Constant (TBC_{ST})

2) Calculate "X" where

$$X = \frac{\text{overload current}}{\text{LT Pick-Up}}$$

3) Solve the equation:

$$\text{trip time(sec)} = \frac{TBC_{ST}}{X^2}$$

15.3 GF Trip Time

With I²T off or for ground fault currents greater than 2 times the CT rating, the GF trip time is a constant equal to the GF Time Band setting.

With I²T on and for currents less than 2 times the CT rating, the GF trip time is determined by the following equation:

$$T = \frac{TBC_{GF}}{X_{GF}^2}$$

Where: T = time to trip in seconds (center of the band)

$$X_{GF} = \frac{\text{ground fault current}}{\text{CT rating}}$$

TBC_{GF} = the GF Time Band Constant

**** NOTE ****

The GF Time Band Constant (TBC_{GF}) =
 2.0 for the .50S Time Band
 1.6 for the .40S Time Band
 1.2 for the .30S Time Band
 0.8 for the .20S Time Band
 0.4 for the .10S Time Band

EXAMPLE #3:

CT Rating 1600A
 LT pick-up 1200A
 GF pick-up 640A
 GF time band .20S I²T ON
 Ground Fault Current 800A

TBC_{GF} = 0.8

and $X_{GF} = \frac{\text{ground fault current}}{\text{CT Rating}} = \frac{800A}{1600A}$
 = 0.5

therefore:

trip time = $T = \frac{TBC_{GF}}{X_{GF}^2}$ or $\frac{0.8}{(0.5)^2} = \frac{0.8}{.25}$
 = 3.20 sec

**** IN SUMMARY ****

- To calculate the GF I²T trip time:
- 1) Determine the GF Time Band Constant (TBC_{GF})
 - 2) Calculate "X_{GF}" where
 $X_{GF} = \frac{\text{ground fault current}}{\text{CT Rating}}$
 - 3) Solve the equation:
 trip time(sec) = $\frac{TBC_{GF}}{X_{GF}^2}$

15.4 U/B Trip Time

U/B is calculated as follows:

$$U/B = \frac{(I_{NL} - I_{NS}) \times 100\%}{I_{NL}}$$

Where:

I_{NL} = Largest Phase current
 I_{NS} = Smallest Phase current

The U/B function is defeated if any two phase currents are less than 10% of the CT rating.

The tolerance for the U/B Pick-Up is ± 10 percentage points. An U/B Pick-Up of 20% would have a tolerance of 10% to 30% unbalance. An U/B Pick-Up of 50% would have a tolerance of 40% to 60% unbalance.

The U/B trip time is a definite time as shown on the U/B TCC in Figure 17.3

The tolerance for the U/B trip time is ± 10% of the setting.

16.0 Error Message Summary

The following is a summary of the possible error messages and what action is necessary to correct the problem.

16.1 Actuator Not Connected

When the actuator is not connected or is open circuited, the following message will be displayed:

NO ACTUATOR

All push buttons are disabled. To return to normal operation, a functioning actuator must be connected.

16.2 Memory Error

The micro-controller continuously monitors its memory. When a discrepancy occurs, the following message will be displayed:

MEMORY ERROR

All push buttons are disabled. The micro-controller must be replaced. Contact Utility Relay Company for more information.

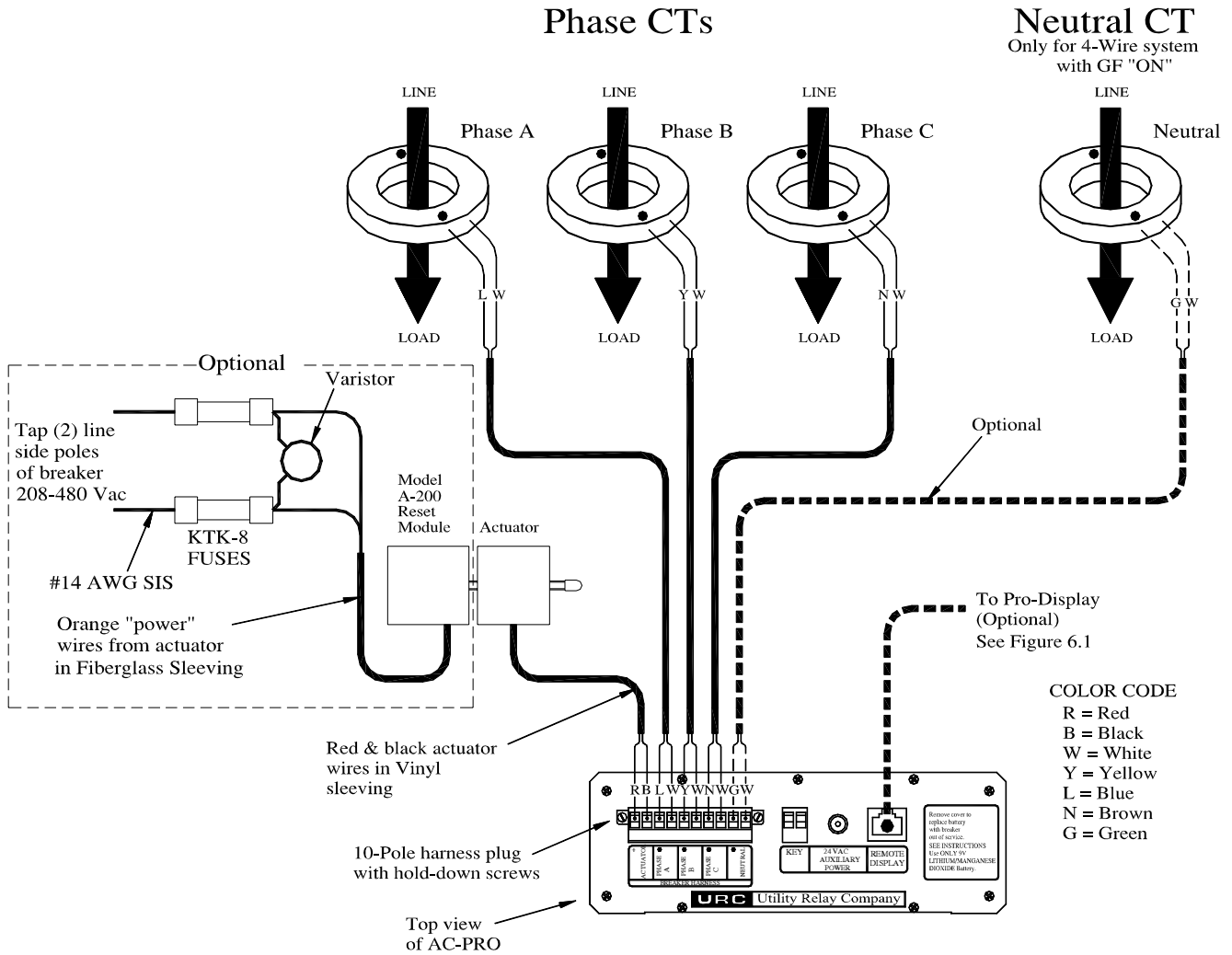

Figure 17.1
Typical Wiring Diagram

INTENTIONALLY LEFT BLANK

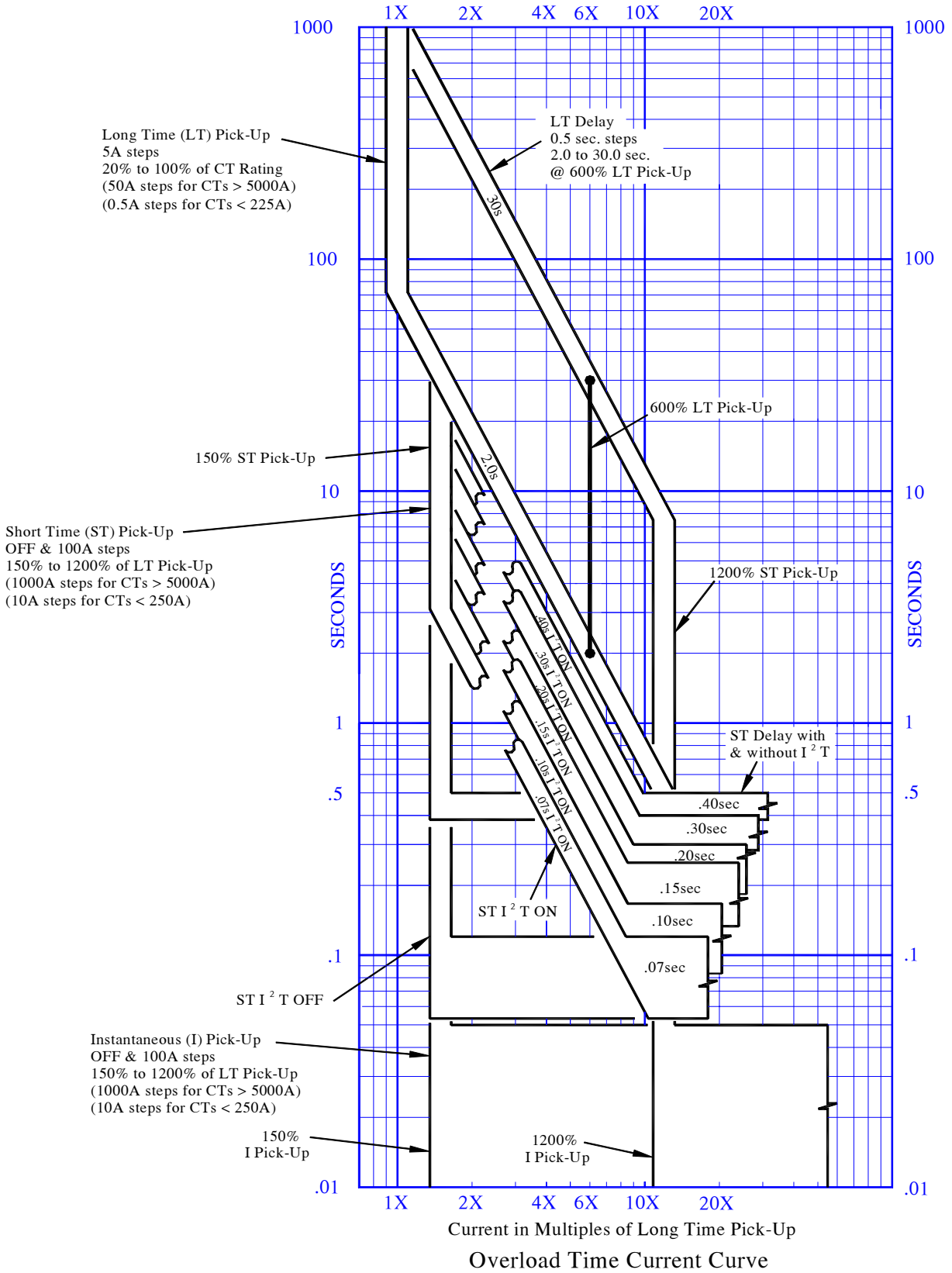

Figure 17.2
Overload TCC

INTENTIONALLY LEFT BLANK

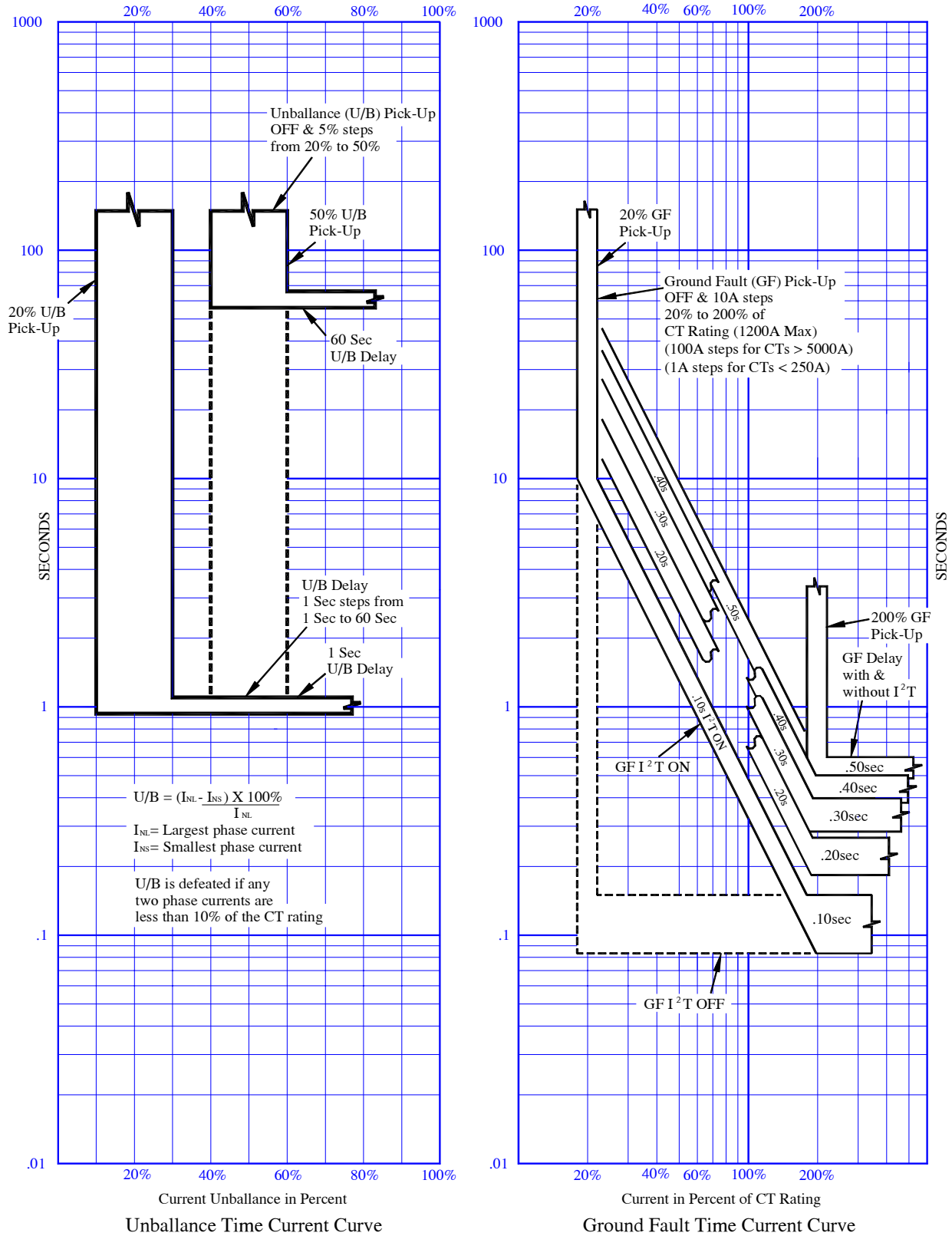

Figure 17.3
U/B & GF TCC

INTENTIONALLY LEFT BLANK

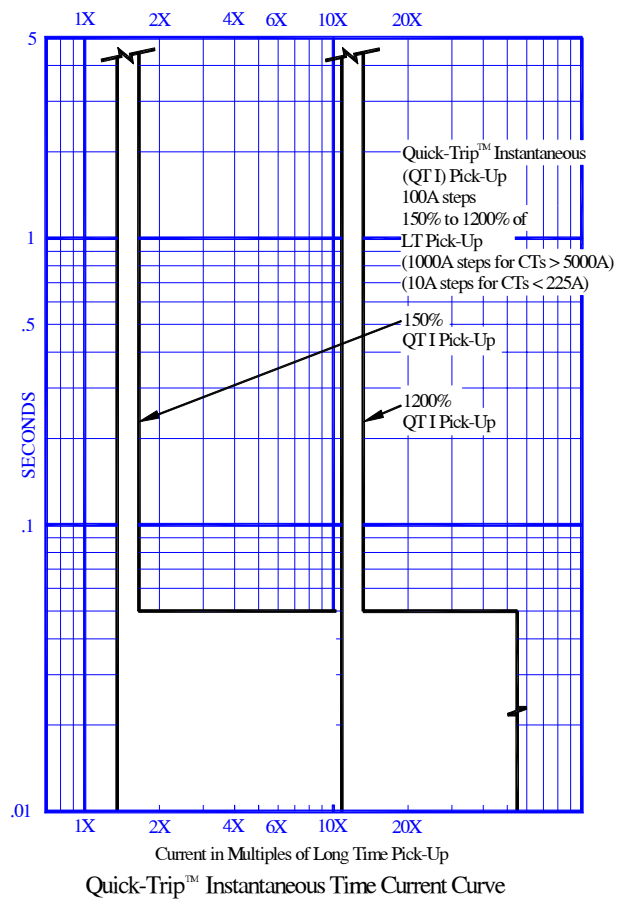
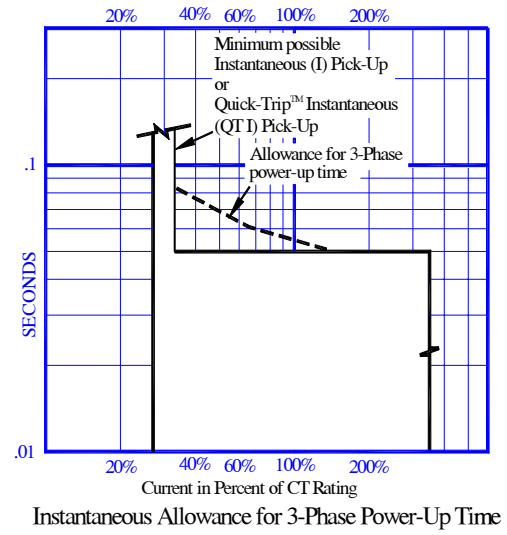
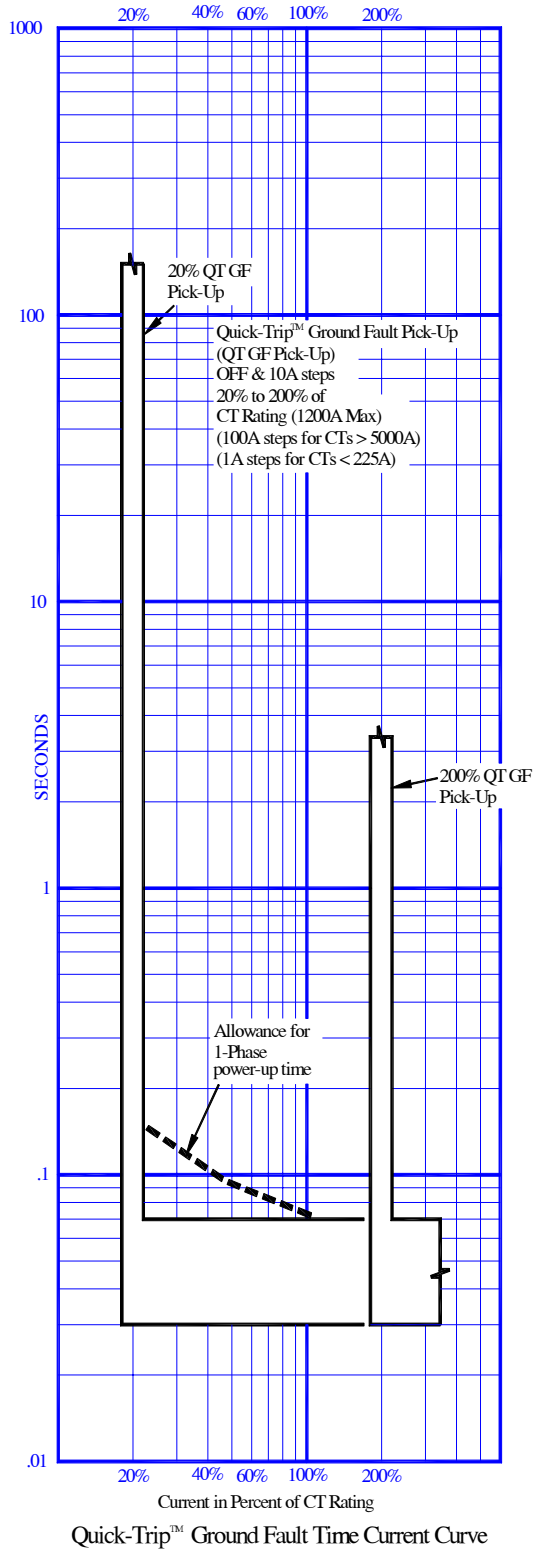

Figure 17.4
QUICK-TRIP™ Ground Fault & Instantaneous TCC

INTENTIONALLY LEFT BLANK