

# COMMUNICATIONS

I-COMM MANUAL

MODBUS / RS-485

**AC-PRO**  
Communicating  
Trip Units

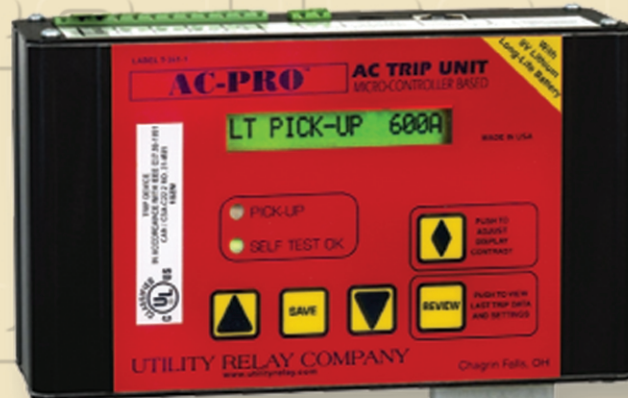

## INSTRUCTION MANUAL

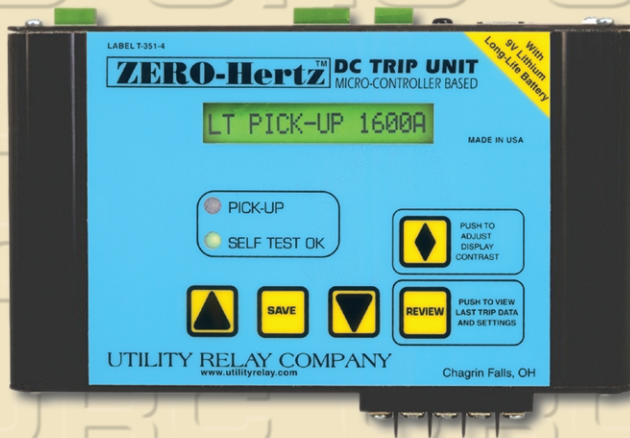

**ZERO-Hertz**  
Communicating  
Trip Units

**URC** Utility Relay Company

Chagrin Falls, OH 44023  
Phone: 888.289.2864  
[www.utilityrelay.com](http://www.utilityrelay.com)

## Table of Contents

<b>1.0</b>	<b>Introduction</b> -----	3
<b>2.0</b>	<b>AC-PRO+ Communications Components</b> -----	4
2.1	AC-PRO+ Trip Unit-----	4
2.2	PT Module -----	4
2.3	AC-PRO+ Breaker Wiring -----	5
<b>3.0</b>	<b>ZERO-Hertz Communications Components</b> -----	6
3.1	ZERO-Hertz Trip Unit-----	6
3.2	ZERO-Hertz Breaker Wiring -----	7
<b>4.0</b>	<b>System Components - Computer Hardware</b> -----	8
4.1	RS-485 Direct -----	8
4.2	RS-232 to RS-485 Conversion -----	9
4.3	Ethernet-----	10
4.4	LCI Ethernet -----	11
<b>5.0</b>	<b>System Components – Software</b> -----	11
5.1	Trip Unit Programming -----	12
5.2	MODBUS (DDE) Driver -----	12
5.3	DDE Addressing (with <i>EXCEL</i> <sup>TM</sup> )-----	13
<b>6.0</b>	<b>Technical Support</b> -----	13
<b>Appendix A</b>	<b>AC-PRO+ MODBUS DDE Item Names</b> -----	14
<b>Appendix B</b>	<b>ZERO-Hertz MODBUS DDE Item Names</b> -----	17

Revision: 1.2  
Date: February 8, 2006

## 1.0 Introduction

Creating a complete power monitoring and communications system for a low voltage power distribution system is easy with Utility Relay Company's AC-PRO+ and ZERO-Hertz communicating trip unit. The trip units communicate using industry standard MODBUS protocol through a single shielded twisted pair wire connected to the RS-485 port. A number of trip units can be daisy-chained together to simplify installation.

Information available from an AC-PRO+ trip unit at each breaker includes:

- Currents, 3-phase ( $\pm 2\%$  accuracy for currents above 10% of CT rating)
- Voltages, 3-phase
- KW, 3-phase ( $\pm 5\%$  accuracy for currents above 10% of CT rating)
- KWH, Total
- KVA, 3-phase
- Power Factor Data
- Breaker Position
- Overload and Alarm Conditions
- Last Trip Data
- Phase Currents at the Time of Trip
- Trip Counter

Information available from a ZERO-Hertz trip unit at each breaker includes:

- DC Current ( $\pm 10\%$  accuracy for currents between 10% & 150% of transducer rating)
- Ground Fault Current (if applicable)
- Current Direction
- Overload and Alarm Conditions
- Last Trip Data
- Trip Current at the Time of Trip
- Trip Counter

A host PC running a MODBUS (DDE) driver collects information from the trip units. The driver interrogates each trip unit individually and reports that information back to the host PC applications on a continual basis. Additional trip units can be added to the system by simply providing the new trip unit's ADDRESS to the MODBUS driver.

AC-PRO+ and ZERO-Hertz trip units are compatible with the MODBUS drivers supplied with most MMI systems such as Wonderware's *INTOUCH*<sup>™</sup>, *Intellution*<sup>™</sup>, Square D's *PowerLogic SMS-3000*<sup>™</sup>, and Power Measurements *PEGASYS*<sup>™</sup>.

## **2.0 AC-PRO+ Comm. Components**

An AC-PRO+ MODBUS Communications system consists of the following hardware components:

1. AC-PRO+ Trip Unit and breaker retrofit components.
2. Host PC (supplied by others).
3. Cabling Topology (supplied by others).

Additional considerations include the system software. Software components include:

1. MODBUS (DDE) Driver (supplied by others).
2. Man-Machine Interface (MMI) System (supplied by others).

## **2.1 AC-PRO+ Trip Unit**

The AC-PRO+ is an enhanced version of the standard AC-PRO trip unit with the addition of power monitoring and communications capability. The AC-PRO+ trip unit contains a communications circuit board, which incorporates an RS-485 port and a PT Module connector; both located on the bottom of the trip unit.

In addition to its power monitoring and communications capability, the AC-PRO+ has all of the protective functions and features of a standard AC-PRO trip unit. Two additional setpoints must be programmed in to the trip unit during commissioning to enable the communications functions. See Section 5.1 Trip Unit Programming.

## **2.2 PT Module**

The PT Module mounts directly on the circuit breaker and connects to the AC-PRO+ via a preassembled wiring harness. In addition to monitoring the individual phase voltages, the PT Module also provides continual power to the AC-PRO+ so that the trip unit can continue to communicate its status even if the breaker is open or not carrying current.

The PT Module also features two addressable relays which can be used to establish a “mini-SCADA system” to control electrical operated breakers from one central PC location.

A PT Module, wiring harness, and mounting hardware are provided with each AC-PRO+ complete retrofit kit.

## 2.3 AC-PRO+ Breaker Wiring

The AC-PRO+ is provided with a quick disconnect communications cable assembly. The cable assembly features a heavy-duty twist-lock connector and a terminal block, which mounts inside the switchgear.

The purpose of the terminal block is to provide a connection location for the twisted pair wire as it is daisy-chained from cell to cell in a switchgear lineup. This enables any individual AC-PRO+ (mounted on a circuit breaker) to be removed without disrupting communications between the other AC-PRO+ trip units.

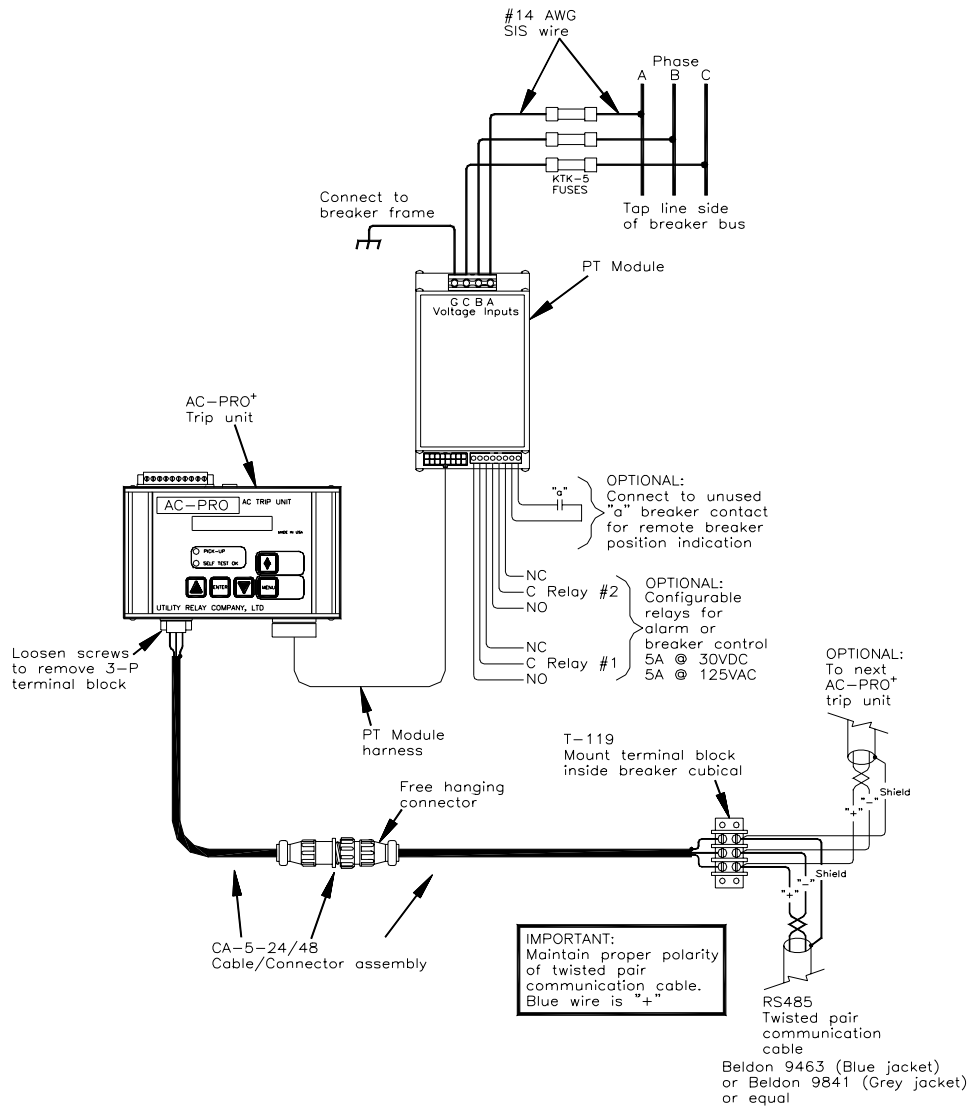

### 3.0 ZERO-Hertz Comm. Components

A ZERO-Hertz MODBUS Communications system consists of the following hardware components:

1. ZERO-Hertz Trip Unit and breaker retrofit components.
2. Host PC (supplied by others).
3. Cabling Topology (supplied by others).

Additional considerations include the system software. Software components include:

1. MODBUS (DDE) Driver (supplied by others).
2. Man-Machine Interface (MMI) System (supplied by others).

### 3.1 ZERO-Hertz Trip Unit

The ZERO-Hertz trip unit is available in four models:

<u>Model Number:</u>	<u>Method of DC Current Sensing</u>		<u>Communications</u>
	<u>Transducers Only</u>	<u>Transducer or Shunt Input</u>	
<b>B-201</b>	<b>YES</b>		
<b>B-202</b>	<b>YES</b>		<b>YES</b>
<b>B-203</b>		<b>YES</b>	
<b>B-204</b>		<b>YES</b>	<b>YES</b>

Trip unit models **B-202** and **B-204** are equipped with an RS-485 MODBUS communications port. This port allows the trip unit to communicate with a host PC or other RS-485-based communications system. In addition to its continuous DC current monitoring and communications capability, the ZERO-Hertz has all of the protective functions and features of a non-communicating ZERO-Hertz trip unit.

Two addition setpoints must be programmed in to the trip unit during commissioning to enable the communications functions. See Section 5.1 Trip Unit Programming.

## 3.2 ZERO-Hertz Breaker Wiring

The ZERO-Hertz is also provided with a quick disconnect communications cable assembly for trip unit models **B-202** and **B-204** equipped with communications. The cable assembly features a heavy-duty twist-lock connector and a terminal block, which mounts inside the switchgear.

The purpose of the terminal block is to provide a connection location for the twisted pair wire as it is daisy-chained from cell to cell in a switchgear lineup. This enables any individual ZERO-Hertz to be disconnected without disrupting communications between the other trip units.

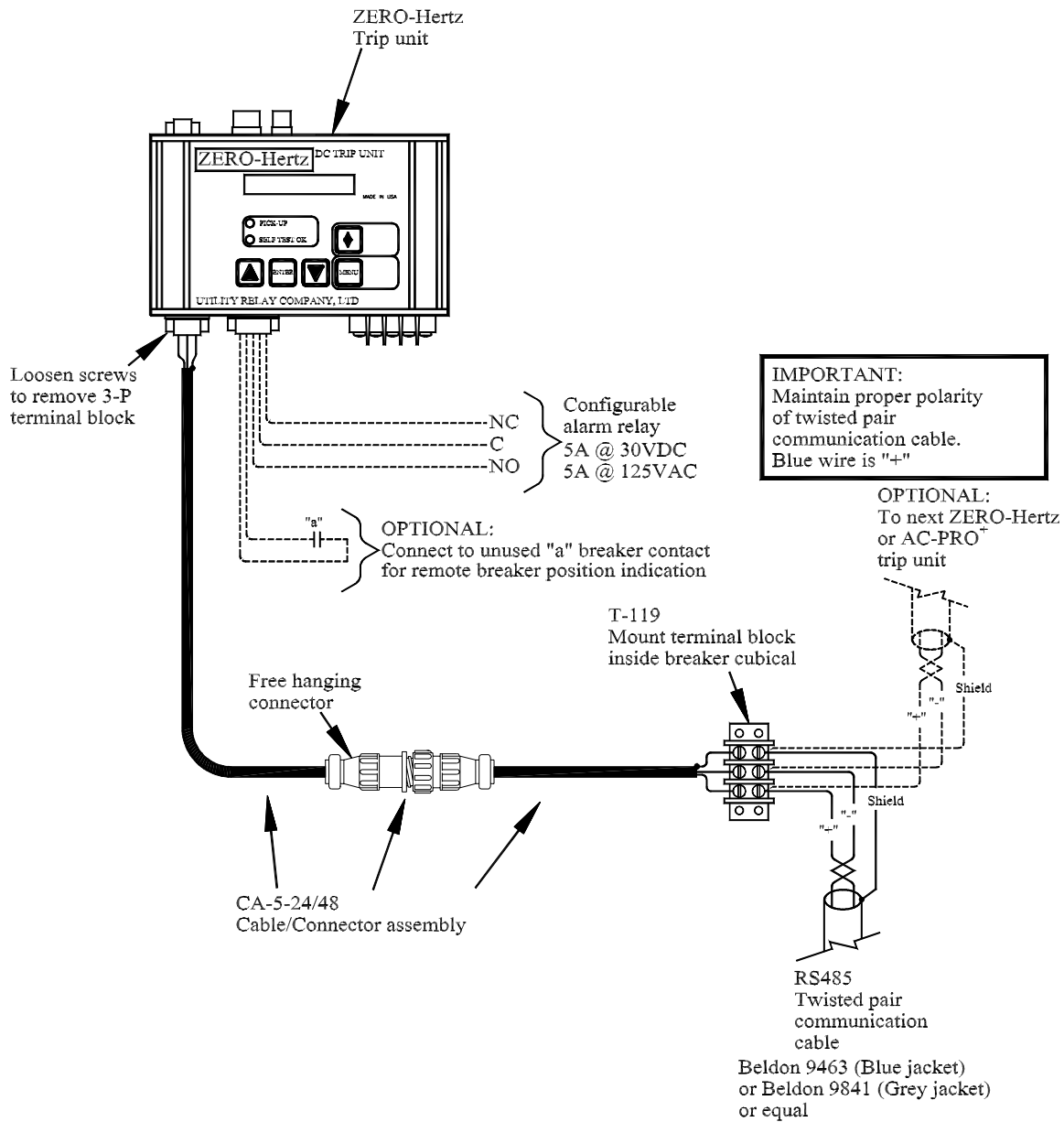

## 4.0 System Components-Computer Hardware

URC trip units communicate over MODBUS RS-485 at 9600 Baud, with 8 data bits, 1 stop bit and no parity. There are four simple hardware configurations to connect between a PC and a URC trip unit on a breaker.

### 4.1 RS-485 Direct

Connecting trip units directly to a PC is an easy way to set up a stand-alone system. The major benefit is that a stand-alone system is that it does not require a large initial investment in hardware. The system can start out small, yet it is flexible enough to allow additional trip units to be added to the system at any time.

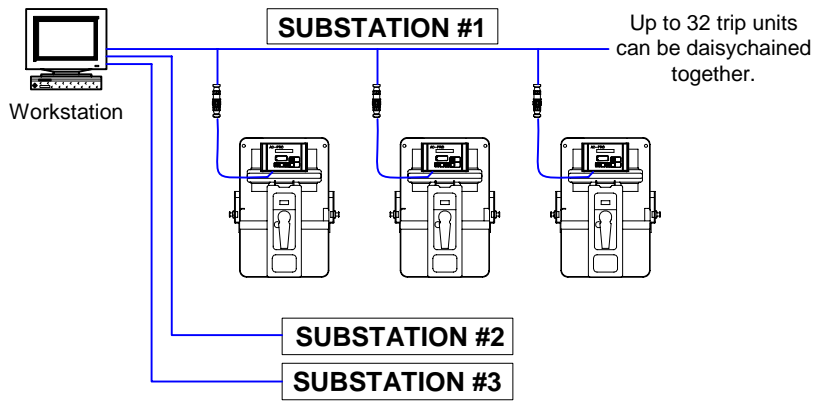

As system demands grow, additional twisted pairs of wire can be added, each twisted pair capable of supporting an additional 32 AC-PRO+ or ZERO-Hertz trip units. The host PC can also be connected to a Local Area Network (LAN), allowing other computer sites access to AC-PRO+ information.

Cable requirements:

- Belden 9463 shielded twisted pair (or equivalent) cabling is recommended
- Maximum cable length is 4000 feet.

## 4.2 RS-232 to RS-485 Conversion

RS-232 communications is a convenient method to periodically monitor trip units without incurring the expense of a network. RS-232 to RS-485 converters and hardware are readily available and inexpensive.

### Using a Laptop

When continual power monitoring and communications is not necessary, a laptop computer is a very useful tool. A substation can be wired for communications with the communications cable terminating at an inexpensive RS-232 to RS-485 converter located in the substation. When required, a laptop computer can be connected directly to the RS-232 computer for periodic monitoring.

At any time, the RS-232 to RS-485 converter can be removed, and the substation can be connected to a larger power monitoring system with the addition of an LCI or other RS-485 to Ethernet Converter.

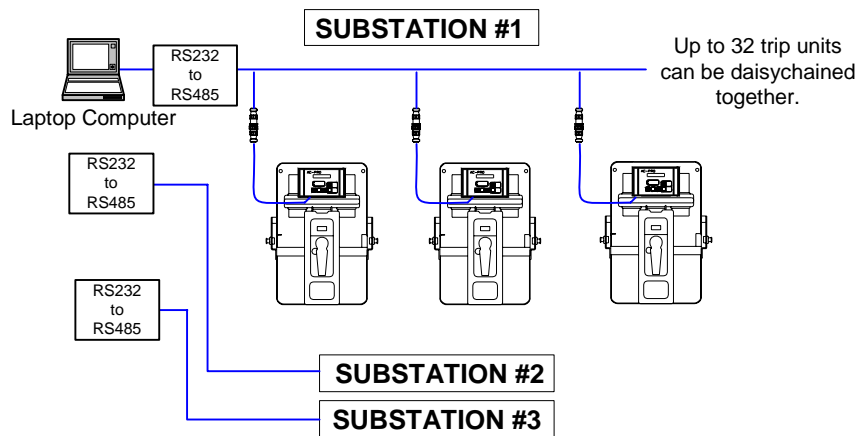

### RS-232 Converters

Most, if not all, RS-232 to RS-485 converters and boards will have 4 wire connections TX+, TX-, RX+, and RX-. The trip units use a 2 wire connection system, so at some convenient point, usually right at the converter or board connector, connect as follows:

- TX+ and RX+ together
- TX- and RX- together

Shielded twisted pair cable should be used between the RS-232 to RS-485 converter and the trip units (Belden 9463 or equivalent cable is recommended).

## 4.3 Ethernet

With the addition of an RS-485 to Ethernet Converter an existing Local Area Network (LAN) can be used to carry data between trip units and the PC. Converters are widely available from a variety of industrial computer manufacturers.

RS-485 to Ethernet Converters are designed to be compatible with a TCP/IP network environment and typically connect to a LAN using standard 10Base-T modular CAT-5 cabling. These converters offer a relatively inexpensive means of connecting to a LAN.

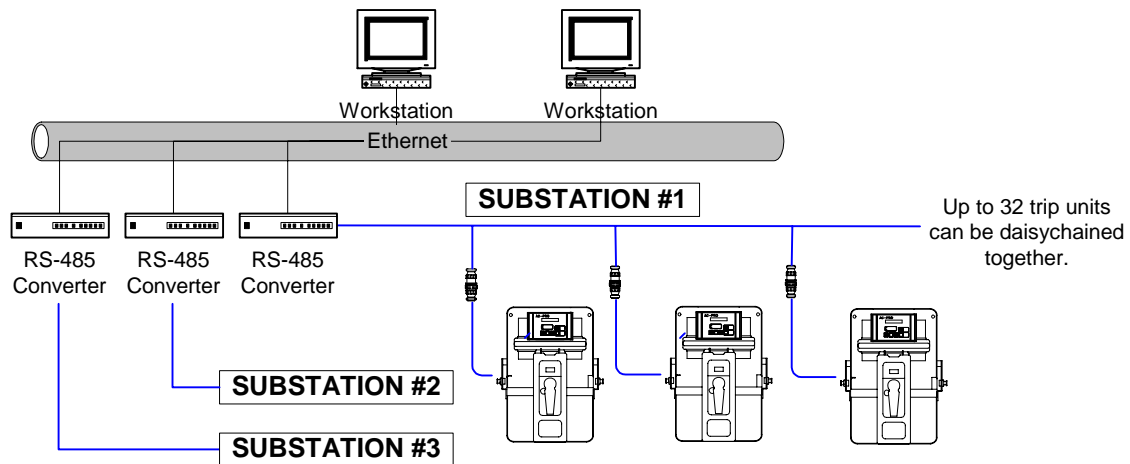

## 4.4 LCI Ethernet

The LCI (Local Communications Interface), manufactured by Utility Relay Company, is a substation monitor that continuously monitors up to 32 AC-PRO+ and/or ZERO-Hertz trip units that are connected to the LCI's RS-485 port. The LCI offers three key benefits:

- 1.) The 4-line X 20-character display provides easy monitoring of a critical power and trip data from any trip unit connected to the RS-485 port.
- 2.) The built-in Ethernet port acts as an "RS-485 to Ethernet Converter" and easily connects to a LAN with a simple CAT-5 cable. A unique IP address for the LCI is user-programmable from the LCI's front panel.
- 3.) Embedded Web Pages in the LCI provide critical information across the LAN with no additional software to install or setup. Information can be accessed by typing the LCI's IP address in the command line of any standard web browser on the LAN.

See Appendix C for more information about the LCI.

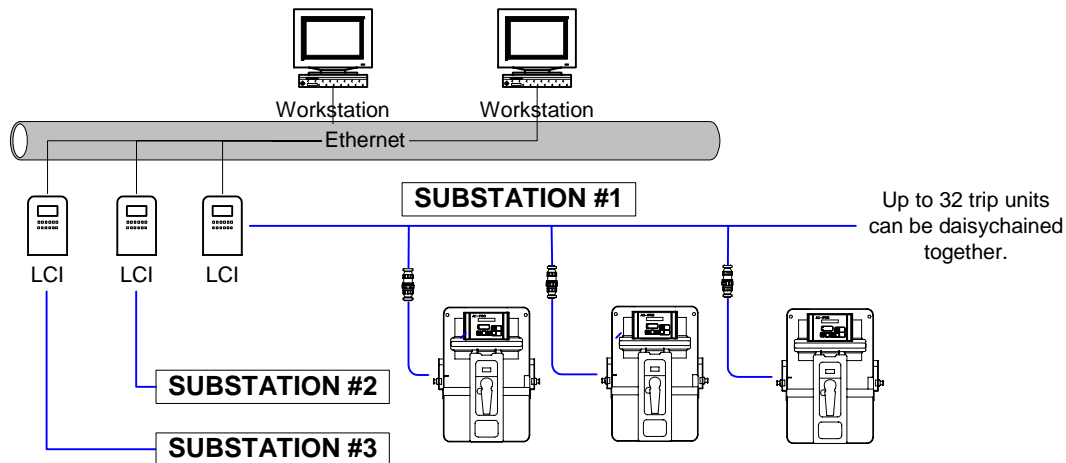

## 5.0 System Components - Software

In addition to AC-PRO+ and/or ZERO-Hertz trip units equipped with an RS-485, the following additional software may be required:

1. MODBUS (DDE) Driver
2. *EXCEL*<sup>™</sup> or *LOTUS 1-2-3*<sup>™</sup> can be used to view information provided by the MODBUS DDE Driver.
3. Man-Machine Interface (MMI) System. These systems are used to view trip unit information graphically and often contain their own compatible MODBUS Driver.

## 5.1 Trip Unit Programming

Both the AC-PRO+ and the ZERO-Hertz trip units have two additional programmable setpoints that are not found on the standard trip units. Those two setpoints are

- ADDRESS
- REPLY DELAY

These setpoints need to be programmed during the normal commissioning of the trip unit (Refer to the section on Commissioning in the AC-PRO or ZERO-Hertz Instruction Manual). The setpoints appear after all of the Pick-Up and Delays settings have been made.

### **ADDRESS**

Each trip unit that shares the same twisted pair must have a unique address. The address is selectable from 1 to 127 in increments of 1. In most applications only addresses 1 thru 32 will be used due to the limitations of RS-485 communications.

The ADDRESS identifies each individual trip unit connected to the same twisted pair wire.

NOTE: Two trip units can have the same ADDRESS as long as they are not connected to the PC, Ethernet converter or RS-232 converter via the same twisted pair cable.

### **REPLY DELAY**

The REPLY DELAY setpoint is the minimum delay between the trip unit's receipt of a MODBUS packet and its reply. Adjusting it enables the trip unit to operate properly with other manufacturers' MODBUS RS-485 connections. The reply delay can be either 5 or 10 milliseconds.

The factory default of this setpoint is 5 milliseconds.

## 5.2 MODBUS (DDE) Driver

The MODBUS (DDE) Driver runs on the Host PC and communicates with the trip units. It creates the communications messages, sends them, and retrieves the responses. This data can then be shared with most *WINDOWS*<sup>TM</sup> programs requesting information (via DDE). DDE is supported by most MMI systems such as Wonderware's *INTOUCH*<sup>TM</sup>, Square D's *PowerLogic SYSTEM MANAGER*<sup>TM</sup>, and Power Measurements *PEGASYS*<sup>TM</sup> and *ION*<sup>TM</sup>. Most of these MMI systems already include a MODBUS-DDE Driver that is compatible with the AC-PRO+ and ZERO-Hertz trip units.

Other programs which accept DDE include *EXCEL*<sup>TM</sup>, *WORD*<sup>TM</sup> and *LOTUS 1-2-3*<sup>TM</sup>. These programs do not contain a MODBUS (DDE) Driver. A downloadable MODBUS (DDE) Driver from *KEPWARE*<sup>TM</sup> (along with installation instructions) is available at: [http://www.utilityrelay.com/comm\\_sys\\_software.htm](http://www.utilityrelay.com/comm_sys_software.htm)

The free version of this driver provides a 2-hour continuous runtime environment with an unlimited number of restarts.

The MODBUS Driver runs in the background on the host PC and immediately begins to communicate with all of the trip units connected to the PC when the Driver program is started. The only time that the Driver needs to be modified is when a trip unit is added or removed from the system.

## 5.3 DDE Addressing with EXCEL™

Dynamic Data Exchange (DDE) is a programming format that allows most programs running under *WINDOWS™* to request and receive data from other programs. Programs such as *EXCEL™* or *LOTUS 1-2-3™* use DDE requests to get specific data from a MODBUS DDE Driver.

DDE requests include a formatted “address” of the data being sought. *WINDOWS™* is responsible for processing those requests and retrieving data from the MODBUS-DDE Driver.

DDE data consists of the following components:

1. DDE Source Name
2. Topic Name
3. Item Name

DDE Source Name – This is the name of the DDE Driver being used.

Topic Name – This is the name of the trip unit to be addressed. The Topic Name must be defined in the MODBUS-DDE Driver (by its ADDRESS and COM port or TCP/IP settings).

Item Name – The data point to read or write. “Item Names” are frequently numbers, but are still called “Names”.

The format of a DDE address is as follows:

*DDE SourceName | TopicName!'ItemName'*

For example, in Microsoft *Excel™*, the following command could be typed into a cell to retrieve a piece of data (NOTE: The following *syntax* is for the *INTOUCH* Wonderware MODBUS DDE driver):

MODBUS|BREAKER1!'256 IR'

Where:

MODBUS is the DDE Source Name .

BREAKER1 is the Topic Name defined by the user using MODBUS.

256 IR is the Item Name of the desired piece of information from the trip unit.

**NOTE:** The AC-PRO+ and ZERO-Hertz are compatible with most MODBUS drivers.  
You will need to consult the specific MODBUS driver manufacturer for the proper syntax.

See Appendix A for a complete list of available Item Names for AC-PRO+ trip units.

See Appendix B for a complete list of available Item Names for ZERO-Hertz trip units.

## 6.0 Technical Support

For technical support, contact Utility Relay Company 888-289-2864, or visit us on the web at [www.utilityrelay.com](http://www.utilityrelay.com)

## Utility Relay Company

### Appendix A AC-PRO+ MODBUS DDE Item Names

#### PRODUCT UPDATES THAT REQUIRED NEW MODBUS (DDE) ITEMS

Date	New AC-PRO+ feature	Did Any Old Item Names Change?
February 1, 2003	Kilowatt Hours	Yes †
February 1, 2006	Quick-Trip	No

† The old names are shown *in italics*, to the left of the new names.

Old Item Name	Item Name	Description (Data Point Name)	Unit	Size	Tag Type
	83	Force Reset	N/A	Bit	DO
	84	Force Trip	N/A	Bit	DO
	86	Force Clear Last Trip Data	N/A	Bit	DO
	111	Force Clear KW-Hrs <b>(after 2/1/03)</b>	N/A	Bit	DO
	112	Force Relay 1	N/A	Bit	DO
	113	Force Relay 2	N/A	Bit	DO
	256	Current Phase A	Amps	Word	IR
	257	Current Phase B	Amps	Word	IR
	258	Current Phase C	Amps	Word	IR
	259	Current GF	Amps	Word	IR
	260	Current UB	%	Word	IR
	262	Voltage AG	Volts	Word	IR
	263	Voltage BG	Volts	Word	IR
	264	Voltage CG	Volts	Word	IR
	265	Voltage AB	Volts	Word	IR
	266	Voltage BC	Volts	Word	IR
	267	Voltage CA	Volts	Word	IR
	268	KW Phase A	kW	Word	IR
	269	KW Phase B	kW	Word	IR
	270	KW Phase C	kW	Word	IR
272	271	KVA Phase A	kVA	Word	IR
273	272	KVA Phase B	kVA	Word	IR
274	273	KVA Phase C	kVA	Word	IR
	274	KW-Hrs Register 3	.1 KWH * 2 <sup>32</sup>	Word	IR
	275	KW-Hrs Register 2	.1 KWH * 2 <sup>16</sup>	Word	IR
	276	KW-Hrs Register 1	.1 KWH	Word	IR
271	277	KW Signs & Lead/Lag PF Bit 0; Phase A, 1 = Lead PF, 0 = Lag PF Bit 1; Phase B, 1 = Lead PF, 0 = Lag PF Bit 2; Phase C, 1 = Lead PF, 0 = Lag PF Bit 8; Phase A KW, 1 = Pos, 0 = Neg Bit 9; Phase B KW, 1 = Pos, 0 = Neg Bit 10; Phase C KW, 1 = Pos, 0 = Neg Bit 11; KW-Hrs, 1 = Pos, 0 = Neg <b>(N/A for trip units made before 2/1/2003)</b>	N/A	Word	IR

# AC-PRO+ / ZERO-Hertz, Communications System - Instruction Manual

Old Item Name	Item Name	Description (Data Point Name)	Unit	Size	Tag Type
275	278	Alarm Code Bit 0; 1 = Trip Output Bit 1; 1 = Current > LT Pickup Bit 3; 1 = Actuator Disconnected Bit 4; 1 = Memory Error Bit 8; 1 = Breaker Closed, 0 = Breaker Open or Feature Unused Bit 9; 1 = Times 10 Range Bit 11; 1 = Divide by 10 Range	N/A	Word	IR
276	279	CT Rating	Amps	Word	HR
277	280	LT Pickup	Amps	Word	HR
278	281	LT Delay Value stored is 2 times the actual delay in seconds	Sec.	Word	HR
279	282	ST Pickup	Amps	Word	HR
280	283	ST Delay Binary 0 = .07 Sec Delay Band Binary 1 = .10 Sec Delay Band Binary 2 = .15 Sec Delay Band Binary 3 = .20 Sec Delay Band Binary 4 = .30 Sec Delay Band Binary 5 = .40 Sec Delay Band (N/A for trip units made before 2/1/03)	Sec.	Word	HR
281	284	ST I <sup>2</sup> T Bit 0; 0 = Off, 1 = On	N/A	Word	HR
282	285	I Pickup	Amps	Word	HR
283	286	GF Pickup	Amps	Word	HR
284	287	GF Delay Binary 0 = .10 Sec Delay Band Binary 1 = .20 Sec Delay Band Binary 2 = .30 Sec Delay Band Binary 3 = .40 Sec Delay Band Binary 4 = .50 Sec Delay Band	Sec.	Word	HR
285	288	GF I <sup>2</sup> T Bit 0; 0 = Off, 1 = On	N/A	Word	HR
286	289	U/B Pickup	%	Word	HR
287	290	U/B Delay	Sec.	Word	HR
288	291	Trip Unit Address	N/A	Word	HR
289	292	Reply Delay	mS	Word	HR
290	293	Last Trip Current Phase A	Amps	Word	IR
291	294	Last Trip Current Phase B	Amps	Word	IR
292	295	Last Trip Current Phase C	Amps	Word	IR
293	296	Last Trip Current GF	Amps	Word	IR
294	297	Last Trip Current U/B	%	Word	IR
295	298	Last Trip Code Binary 0 = Instantaneous Binary 1 = LT Binary 2 = ST Binary 3 = GF Binary 4 = Unbalanced Binary 5 = Forced Trip Thru Communications Binary 7 = QT Ground Fault (after 2/1/06) Binary 8 = QT Instantaneous (after 2/1/06) Binary 65535 = No Last Trip	N/A	Word	IR

## Utility Relay Company

---

<b>Old Item Name</b>	<b>Item Name</b>	<b>Description (Data Point Name)</b>	<b>Unit</b>	<b>Size</b>	<b>Tag Type</b>
296	299	Trip Count Instantaneous	N/A	Word	IR
297	300	Trip Count LT	N/A	Word	IR
298	301	Trip Count ST	N/A	Word	IR
299	302	Trip Count GF	N/A	Word	IR
300	303	Trip Count U/B	N/A	Word	IR
301	304	Trip Count Forced	N/A	Word	IR
303	306	Serial Number Byte 0	N/A	Word	IR
304	307	Serial Number Byte 1	N/A	Word	IR
305	308	Serial Number Byte 2	N/A	Word	IR
306	309	Serial Number Byte 3	N/A	Word	IR
307	310	Serial Number Byte 4	N/A	Word	IR
308	311	Serial Number Byte 5	N/A	Word	IR
309	312	Serial Number Byte 6	N/A	Word	IR
	317	Quick-Trip GF Pickup	Amp	Word	HR
	318	Quick-Trip Instantaneous Pickup	Amp	Word	HR
	321	Trip Count Quick-Trip GF	N/A	Word	IR
	322	Trip Count Quick-Trip Instantaneous	N/A	Word	IR

## Appendix B ZERO-Hertz MODBUS DDE Item Names

Item Name	Description (Data Point Name)	Unit	Size	Tag Type
83	Force Reset	N/A	Bit	DO
84	Force Trip	N/A	Bit	DO
86	Force Clear Last Trip	N/A	Bit	DO
87	Force Alarm Relay On	N/A	Bit	DO
88	Force Alarm Relay Off	N/A	Bit	DO
256	Largest Current	Amps	Word	IR
257	Current GF	Amps	Word	IR
258	Direction Bit 0; 0 = Forward, 1 = Reverse	N/A	Word	IR
259	Alarm Code Bit 0; 1 = Trip Output Bit 1; 1 = Current > LT Pickup Bit 3; 1 = Actuator Disconnected Bit 4; 1 = Memory Error Bit 5; 1 = Xducer Error Bit 6; 1 = A/D Error Bit 7; 1 = Alarm Relay in Alarm State Bit 8; 1 = Breaker Closed, 0 = Breaker Open or Feature Unused Bit 9; 1 = Times 10 Range Bit 10; 1 = Minus Transducer is Present	N/A	Word	IR
260	Last Trip Code Binary 0 = Instantaneous Binary 1 = LT Binary 2 = ST Binary 3 = GF Binary 5 = Forced Trip Thru Communications Binary 7 = Reverse Current Binary 8 = UV OL Binary 65535 = No Last Trip	N/A	Word	IR
261	Last Trip Current	Amps	Word	IR
262	Last Trip Current GF	Amps	Word	IR
263	Last Trip Direction Bit 0; 0 = Forward, 1 = Reverse	N/A	Word	IR
264	Trip Count Instantaneous	N/A	Word	IR
265	Trip Count LT	N/A	Word	IR
266	Trip Count ST	N/A	Word	IR
267	Trip Count GF	N/A	Word	IR
269	Trip Count Forced	N/A	Word	IR
271	Trip Count Reverse	N/A	Word	IR
272	Trip Count UV OL	N/A	Word	IR
274	Serial Number Byte 0	N/A	Word	IR
275	Serial Number Byte 1	N/A	Word	IR
276	Serial Number Byte 2	N/A	Word	IR
277	Serial Number Byte 3	N/A	Word	IR
278	Serial Number Byte 4	N/A	Word	IR
279	Serial Number Byte 5	N/A	Word	IR
280	Serial Number Byte 6	N/A	Word	IR
282	DC Input Bit 0; 0 = Transducer, 1 = Shunt	N/A	Word	IR

## Utility Relay Company

Item Name	Description (Data Point Name)	Unit	Size	Tag Type
283	Transducer Rating	Amps	Word	IR
284	LT Pickup	Amps	Word	HR
285	LT Delay Value stored is 2 times the actual delay in seconds	Sec.	Word	HR
286	LT & ST Thermal Memory Bit 0; 0 = Off, 1 = On	N/A	Word	HR
287	ST Pickup	Amps	Word	HR
288	ST Delay Binary 0 = .07 seconds Binary 1 = .10 seconds Binary 2 = .15 seconds Binary 3 = .20 seconds Binary 4 = .35 seconds	Sec.	Word	HR
289	ST I <sup>2</sup> T Bit 0; 0 = Off, 1 = On	N/A	Word	HR
291	I Pickup	Amps	Word	HR
292	GF Pickup	Amps	Word	HR
293	GF Delay Binary 0 = .10 seconds Binary 1 = .20 seconds Binary 2 = .30 seconds Binary 3 = .40 seconds Binary 4 = .50 seconds	Sec.	Word	HR
294	GF I <sup>2</sup> T Bit 0; 0 = Off, 1 = On	N/A	Word	HR
295	RC Pickup	Amps	Word	HR
296	RC Delay Binary 0 = .10 seconds Binary 1 = .20 seconds Binary 2 = .30 seconds Binary 3 = .40 seconds	Sec.	Word	HR
297	RC I <sup>2</sup> T Bit 0; 0 = Off, 1 = On	N/A	Word	HR
301	Unit Address	N/A	Word	IR
302	Reply Delay	mS	Word	HR
303	Alarm Relay Under Comm. Control Bit 0; 0 = Off, 1 = On	N/A	Word	HR
304	Alarm Relay on Overload Bit 0; 0 = Off, 1 = On	N/A	Word	HR
305	Alarm Relay on Trip Bit 0; 0 = Off, 1 = On	N/A	Word	HR
306	Alarm Relay on Error Bit 0; 0 = Off, 1 = On	N/A	Word	HR